

Boston Scientific

VICI VENOUS STENT[®] System

Instructions for Use

TABLE OF CONTENTS

WARNING	3
DEVICE DESCRIPTION	3
Figure 1. VICI Stent with RO markers.....	3
Sterilization.....	4
Contents.....	4
INTENDED USE	4
INDICATIONS FOR USE	4
CONTRAINDICATIONS	4
WARNINGS	4
PRECAUTIONS	6
MAGNETIC RESONANCE IMAGING (MRI)	7
ADVERSE EVENTS	8
VIRTUS CLINICAL STUDY	9
Table 1. Overview of VIRTUS Primary Safety and Effectiveness Results	9
Table 2. Demographics and Baseline Characteristics, All Subjects (N=170)	11
Table 3. Medical History, All Subjects (N=170)	13
Table 4. Implant Procedure Parameters, All Subjects (N=170)	14
Table 5. VICI Stent Sizes Utilized – Pivotal Cohort	14
Table 6. Summary of Major Adverse Events.....	15
Table 7. Primary Effectiveness Endpoints, All Subjects (N=170)	15
Table 8. Completed Cases Effectiveness Analysis	15
Table 9. Month 12 Patency Result Based on DUS and IVUS.....	17
Table 10. Month 12 Maximum Percentage Stenosed Based on IVUS Areas	17
Table 11. CIVIQ-20 Results – Pivotal Cohort.....	19
Table 12. Primary Patency by Gender	21
Table 13. Rates of Site-Reported Serious Adverse Events to 425 Days Intent-to-Treat, All Subjects (N=170).....	21
Table 14. Rates of Site-Reported Device or Procedure Related Adverse Events to 425 Days Intent-to-Treat, All Subjects (N=170)	27
HOW SUPPLIED	30
Handling and Storage	30
RECOMMENDED MATERIALS	30
OPERATIONAL INSTRUCTIONS	30
Procedure	30
Table 15. Stent Foreshortening Information	30
Patient Preparation	31
Figure 2. Illustration of Delivery System	32
Product Disposal.....	34
DEFINITION OF SYMBOLS	35
LIMITED WARRANTY	36

Rx ONLY

Caution: Federal Law (USA) restricts this device to sale by or on the order of a physician.

WARNING

Contents supplied STERILE using an ethylene oxide (EO) process. Do not use if sterile barrier is damaged. If damage is found, call your Boston Scientific representative.

For single use only. Do not reuse, reprocess or re-sterilize. Reuse, reprocessing or re-sterilization may compromise the structural integrity of the device and/or lead to device failure which, in turn, may result in patient injury, illness or death. Reuse, reprocessing or re-sterilization may also create a risk of contamination of the device and/or cause patient infection or cross-infection, including, but not limited to, the transmission of infectious disease(s) from one patient to another. Contamination of the device may lead to injury, illness or death of the patient.

After use, dispose of product and packaging in accordance with hospital, administrative and/or local government policy.

Carefully read all instruction prior to use. Observe all warnings and precautions noted throughout these instructions. Failure to do so may result in complications.

DEVICE DESCRIPTION

The VICI VENOUS STENT® System is comprised of two components: the implantable endoprosthesis and the stent delivery system. The stent is a laser cut self-expanding stent composed of a nickel titanium alloy (nitinol). On both the proximal and distal ends of the stent, four radiopaque (RO) markers made of tantalum increase visibility of the stent to aid in placement. **Figure 1** provides an illustration of the VICI VENOUS STENT with RO markers and includes an enlarged view of the RO markers. The stent is constrained in a 9F (maximum 3mm outside diameter) delivery system. The delivery system is a coaxial design with an exterior shaft to protect and constrain the stent prior to deployment. The delivery system is an Over-the-Wire system compatible with 0.035in (0.89mm) guidewires.

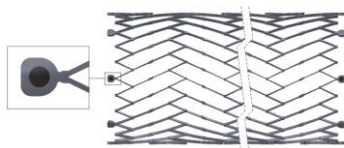

Figure 1. VICI Stent with RO Markers

The VICI VENOUS STENT Delivery System delivers the stent in a distal-to-proximal direction with the standard “pin and pull” method. After obtaining access to the vessel, the physician prepares the System by flushing the inner lumen and Outer Shaft with heparinized saline. When the physician is ready to deploy a stent in a patient, the

delivery system is inserted into the vasculature over an 0.035in guidewire that runs through the entire inner lumen of the delivery system. The delivery system is advanced to the location where the stent is to be deployed.

The physician will determine the specific location of the vessel to land the first part of the stent. A radiopaque marker at the distal end of the delivery system aids in visibility during placement and deployment. Under fluoroscopic guidance, the physician will align the distal end of the VICI VENOUS STENT and the selected Delivery System with the desired location. The physician deploys the stent by “pinning” the proximal end of the inner catheter (i.e., inner shaft hub) and “pulling” the outer shaft back. This exposes the distal end of the stent and, as the outer shaft is pulled more, the stent length is progressively uncovered until the proximal end of the VICI stent is exposed and opens in the vasculature. As the stent is exposed to body temperature, it expands to appose the vessel wall.

The VICI VENOUS STENT is available in a variety of stent diameters and lengths. Please see the product label for the specific stent length and diameter.

Sterilization

The VICI VENOUS STENT System has been sterilized with ethylene oxide.

Contents

One (1) VICI VENOUS STENT Delivery System

INTENDED USE

The VICI VENOUS STENT is intended for the treatment of obstructions and occlusions in the venous vasculature.

INDICATIONS FOR USE

The VICI VENOUS STENT System is indicated for improving luminal diameter in the iliofemoral veins for the treatment of symptomatic venous outflow obstruction.

CONTRAINDICATIONS

The VICI Venous Stent System is contraindicated for use in:

- Patients who are judged to have a lesion that prevents complete inflation of a balloon dilatation catheter or proper placement of the stent or the stent delivery system.
 - Patients who cannot receive intraprocedural anti-coagulation therapy.
-

WARNINGS

- Do not use after the “Use By” date specified on the package. Ensure that the device has been stored in a cool, dry place prior to use.
- Safety and efficacy for stenting outside of the Common Iliac Vein (CIV), External Iliac Vein (EIV), and Common

Femoral Vein (CFV) with the VICI VENOUS STENT has not been studied.

- Stenting in the region of the inguinal ligament in some patients may result in an increased risk in stent fracture.
- For compressive lesions in the CIV, the VICI VENOUS STENT does not need to be extended across the Inferior Vena Cava (IVC). Physicians should extend the stent up to 1.0cm beyond the compressive lesion.
- The VICI VENOUS STENT System has not been evaluated for contralateral access. This access approach is not recommended.
- **Instructions:** Carefully read all instructions prior to use. Observe all Warnings and Precautions noted throughout these instructions. Failure to do so may result in peri- or post-procedural complications.
- **Access:** This device is designed for ipsilateral femoral or popliteal and jugular access only. Access site should allow for adequate assessment of disease and inflow.
- **Training:** Only physicians who have received appropriate training in the principles, clinical applications, complications, side effects, and hazards commonly associated with interventional vascular procedures should use this device.
- **Sizing:** To eliminate risk of stent migration or stent movement, do not deploy the VICI VENOUS STENT unless the target diameter has been properly measured. Improper stent size selection can lead to stent migration or inadvertent stent movement.
 - The diameter of the stent should be 1mm - 2mm greater than (“over”) the measured diameter of the surrounding “normal” vein.
 - In post-thrombotic diseased veins, target veins should be pre-dilated to the reference vein diameter.
 - In non-thrombotic lesions, size stent diameter to ensure stent engagement in area of central focal compressive lesion (e.g., vessel crossing) and adequate wall apposition in peripheral normal veins.
 - Dilated veins peripheral to stenosis are not normal veins, and therefore should not be used to measure reference vein diameter and stent diameter selection.
 - Excessive oversizing of stents has been reported to contribute to post-operative patient pain.
 - The stented length should be at least 1cm longer than the obstructive venous lesion (a minimum of 0.5cm centrally and 0.5cm peripherally).
- **Delivery System Position:** Failure to maintain delivery system position during stent deployment may lead to placement of the stent in an unintended site.
- **Stent Deployment:** The VICI VENOUS STENT cannot be recaptured into the delivery system once it is partially deployed. Attempted recapture may result in damage to the vein.
 - Careful attention should be used to avoid stretching or compressing the stent during

deployment, as this may increase risk of stent fracture. During deployment, maintain the position of the Inner Shaft Hub.

- **Delivery System Removal:** Removal of the Delivery System should be under fluoroscopic guidance. If resistance is encountered, do not attempt to remove Delivery System until resistance is cleared.
 - **Overlapping Stents:** Ensure overlap of stents is at least 1cm. Stent lengths should be selected to avoid overlapping stents in the region of the inguinal ligament.
 - **Allergy Information:** The VICI VENOUS STENT is constructed of a nickel-titanium alloy (Nitinol) and tantalum, which are generally considered safe; however, patients who are allergic to these materials or who have a history of metal allergies may have an allergic reaction to this device.
-

PRECAUTIONS

- **Inspection:** Inspect the packaging and device prior to use for any breaches of sterile barrier, bends, kinks, or breaks. If damage is noted, do not use the device.
- **Proper Handling:** Exercise care in handling the VICI VENOUS STENT Delivery System to reduce the possibility of accidental breach of sterile barrier, bending, kinking, or breaking of the device.
- **Flush Lumens:** Always ensure air is removed from all lumens by flushing with sterile heparinized saline prior to use of the device.
- **Product Compatibilities:** Always check compatibility of the device with the guidewire and introducer sheath sizes used.
- **Fluoroscopic Guidance Required:** Never advance a guidewire or introducer sheath/dilator or advance/deploy the stent without fluoroscopic guidance. Multi-planar imaging should be used to confirm position of guidewire across lesion and in target veins.
- **Power Injection:** Do not connect the Delivery System to a power injection system.
- **Resistance:** Never advance or withdraw an endovascular device against resistance until the cause of the resistance is determined. Movement of the device against resistance can result in damage to the device or vessel or inadvertent movement of previously placed stent.
- **Kinks:** Do not use if the delivery system is kinked.
- **Introducer/Guide Sheath Required:**
 - Always use an introducer or guide sheath for the implant procedure to protect the access site.
 - Only advance the stent delivery system over a guidewire.
- **Sizing:** The minimally acceptable sheath French size is printed on the package label. Do not attempt to pass the stent delivery system through a smaller size introducer sheath than indicated on the label.
- **Thrombus:** If thrombus is noted once the stent is expanded, thrombolysis and/or PTA should be considered.

- **Procedural Complications:** In the event of procedural complications such as infection, pseudoaneurysms, or fistula formation, surgical removal of the stent may be required.

MAGNETIC RESONANCE IMAGING (MRI)

MRI Safety Information



Magnetic Resonance Conditional

- Non-clinical testing has demonstrated that the VICI VENOUS STENT System is Magnetic Resonance (MR) Conditional.
 - A patient with the VICI VENOUS STENT can be scanned safely, immediately after placement, in an MR system meeting the following conditions:
 - Static magnetic field of 1.5 T or 3.0 T only.
 - Maximum spatial gradient magnetic field of 4,000gauss/cm (40T/m).
 - Maximum MR system reported, whole body averaged specific absorption rate (SAR) of 2W/kg (Normal Operating Mode).
 - Under the scan conditions defined, the VICI VENOUS STENT is expected to produce a maximum temperature rise of 6°C after 15 minutes of continuous scanning.
 - In non-clinical testing, the image artifact caused by the VICI VENOUS STENT extends approximately 5mm from this device when imaged with a gradient echo pulse sequence and a 3.0 T MR system. The lumen of the VICI VENOUS STENT cannot be visualized on the gradient echo or T1-weighted, spin echo pulse sequences.
-

ADVERSE EVENTS

Placement of the VICI VENOUS STENT should not be attempted by physicians who are not familiar with the possible complications that may occur during interventional endovascular procedures. Potential device or procedure-related complications of interventional endovascular procedures include, but are not limited to:

- Abscess
- Access site complications including: bleeding, pain, tenderness, pseudoaneurysm, hematoma, nerve or vessel damage, or infection
- Allergic or hypersensitivity reactions (drug, contrast, device, or other)
- Amputation
- Aneurysm
- Arteriovenous fistula formation and rupture
- Back pain
- Cerebrovascular dysfunction and/or stroke
- Death
- Embolization
- Entanglement of delivery system in deployed stent
- Fever
- GI bleeding
- Hypotension/hypertension
- Myocardial infarction, ischemia, angina, or other cardiovascular disturbance
- Need for urgent intervention or surgery
- Obstruction of venous tributaries
- Organ failure
- Pneumothorax or respiratory distress, pneumonia and/or atelectasis
- Renal failure
- Restenosis
- Sepsis/Infection
- Stent fracture
- Stent migration, misplacement/jumping, or embolization
- Stent occlusion
- Stent thrombosis
- Thrombophlebitis
- Tissue ischemia/necrosis
- Vasospasm
- Vein thrombosis
- Venous congestion
- Venous occlusion
- Vessel injury, examples include dissection, intimal tear, rupture or perforation

VIRTUS CLINICAL STUDY

A total of 170 subjects were treated at 22 sites in this prospective, multicenter, single arm, non-randomized study. **Table 1** presents the primary safety and effectiveness results for the VIRTUS study through Month 12 post-index procedure. Two subjects (1.2%) had an MAE as adjudicated by an independent Clinical Events Committee (CEC). There were no subject deaths during the 12 months of follow-up for the VIRTUS study. Sixteen (16) subjects had a CEC qualifying Target Vessel Revascularization (TVR) through 12 months.

Table 1. Overview of VIRTUS Primary Safety and Effectiveness Results

Safety and Effectiveness Results	n/N (%)
Primary effectiveness – Patent at Month 12 (Intent-to-Treat with imputation)	84.0%
Primary effectiveness – Patent at Month 12 (Completed Cases)	104/125 (83.2%)
Primary safety – Freedom from MAE through Day 30	167/169 (98.8%)
Death through Month 12	0/169 (0%)
Target vessel revascularization through Month 12	16/125 (12.8%)

OBJECTIVE: To assess the safety and effectiveness of the VICI VENOUS STENT System in achieving patency of the target venous lesion in subjects who presented with clinically significant chronic non-malignant obstruction of the iliofemoral venous outflow tract.

DESIGN: The VIRTUS study was a prospective, multicenter, single arm, non-randomized clinical study conducted at 22 sites in the U.S. and Europe. A total of 170 subjects were enrolled in the pivotal cohort for the VIRTUS study. A total of 127 subjects had prior venous obstruction associated with thromboembolic disease and were referred to as post-thrombotic (PT) subjects. A total of 43 subjects had iliofemoral venous segment obstruction without previous thromboembolic or intraluminal disease and were referred to as non-thrombotic (NT) subjects.

Subjects considered for enrollment were 18 years of age or older and had the presence of unilateral, clinically significant, chronic non-malignant obstruction of the common femoral vein, external iliac vein, common iliac vein, or any combination thereof, where obstruction is defined as a $\geq 50\%$ reduction in the target vessel lumen diameter as measured by venography during the index procedure. As a result of the venous obstruction, the subject was required to meet at least one of the following clinical indicators: CEAP classification of 3 or higher and/or a VCSS Pain Score of 2 or greater. The intent was to stent the target lesion with only the VICI VENOUS STENT. Subjects with uncontrolled and uncorrected bleeding disorders, a known hypersensitivity to nickel or titanium, a known allergy to

contrast agents that cannot be managed with pre-medication, lesions that cannot be traversed with a guidewire, an obstruction that extends into the inferior vena cava or below the level of the lesser trochanter were excluded from the study.

After the index procedure, subjects were administered anticoagulation and/or antiplatelet therapy in accordance with their physician's direction and institution's guidelines. Enrolled subjects were evaluated at baseline, index procedure, discharge, 1 month, 6 months and 12 months post-index procedure. Additional follow-up evaluations are ongoing for these subjects at 24, 36, 48, and 60 months.

All imaging modalities (venography, duplex ultrasound, IVUS, x-ray) were assessed by independent core labs. Safety events were adjudicated by an independent Clinical Events Committee and an independent Data Safety Monitoring Board assessed the ongoing risk/benefit profile of the study device based on aggregate and individual study subject data.

Primary Safety Endpoint: The primary safety endpoint for this study was a composite endpoint of freedom from any major adverse event within 30 days, as adjudicated by a Clinical Events Committee. The VIRTUS protocol-defined Major Adverse Events (MAEs) are listed below:

- Device or procedure-related death;
- Device or procedure-related bleeding at the target vessel and/or the target lesion or at the access site requiring surgical or endovascular intervention or blood transfusion ≥ 2 units;
- Device or procedure-related arterial or venous injury occurring in the target vessel segment and/or target lesion location or at the access site requiring surgical or endovascular intervention;
- Device or procedure related acute DVT outside of the target vein segment;
- Clinically significant pulmonary embolism defined as being symptomatic with chest pain, hemoptysis, dyspnea, hypoxia etc. AND be documented on CT; or
- Embolization of stent.

Secondary Safety Endpoint: The secondary safety endpoint for this study were all adverse events, all serious adverse events and all device-related adverse events.

Primary Effectiveness Endpoint: The primary effectiveness endpoint is the primary patency rate at 12 months post-intervention, defined as freedom from occlusion by thrombosis and freedom from surgical or endovascular intervention on target vessel which are found to have re-stenosis or stent occlusion to maintain patency and freedom from in-stent stenosis more than 50% by venogram.

Secondary Effectiveness Endpoint: The secondary effectiveness endpoint for this study was a binary response variable based on an improvement in VCSS by at least 50% at 12 months post-intervention.

Additional Effectiveness Endpoints

Estimate Primary-Assisted Patency

Primary-assisted patency is defined as freedom from occlusion regardless of whether an intervention (subsequent to the index procedure) was performed.

Estimate Secondary Patency

Secondary patency is defined as freedom from “permanent” loss of patency determined through last follow-up (irrespective of the number of interventions).

Procedural Technical Success

Procedural technical success is achievement of a final residual target vessel diameter stenosis of 50% as measured on the post-procedural venogram, without skipped lesion regions, with placement of the study device alone with or without post-stenting balloon dilation as needed.

Lesion Success

Lesion success is defined as achievement of $\leq 50\%$ residual diameter stenosis of the target lesion using any percutaneous method (including the use of non-study devices).

Procedural Success

Procedural success is defined as procedural technical success without the occurrence of a Major Adverse Event (MAE) between the index procedure and discharge.

Late Technical Success

Late technical success (through 12 months) is the absence of device movement $>10\text{mm}$ related to anatomical landmarks or any migration leading to symptoms or requiring therapy; absence of stent occlusion by thrombosis or restenosis, defined as reduction in treated segment lumen more than 50% from the post-procedure vessel lumen diameter as measured by post-procedural venogram or DUS and maintenance of structural integrity, defined as the absence of pinching (focal compression), kinking (stent doubling or bending upon itself) that results in $>50\%$ diameter reduction of the stent, recoil (poor radial resistive force) or absence of fractures.

Change in the Quality of Life (CIVIQ-2)

The area under the curve will be calculated for the CIVIQ-2. The mean and 95% confidence intervals for the study patients will be presented.

RESULTS: The results of the VIRTUS study are provided below.

Demographics: The baseline characteristics of the VIRTUS study indicated that the mean \pm SD subject age was 54.4 ± 16.2 years with a range of 20 to 88 years old. The majority of subjects were White, 127/170 (74.7%), and female, 96/170 (56.5%). A large majority of subjects, 145/170 (85.3%), had venous disease in their left leg and, of the remaining subjects, 24/170 (14.1%) had venous disease in their right leg and 1/170 (0.6%) had bilateral venous disease. The majority of subjects were assessed as CEAP Class 3 or higher, 166/170 (97.6%) and their VCSS leg pain for the target limb was reported as “Moderate”, 54/146 (37.0%) or “Severe”, 42/146 (28.8%). **Table 2** provides a summary of the demographics and baseline characteristics for the VIRTUS study.

Table 2. Demographics and Baseline Characteristics, All Subjects (N=170)

Subject Demographic and Baseline Characteristics	Statistic	Results
Age, years	N	170
	median [Q1, Q3]	56 [41, 66]
	mean \pm SD	54.4 \pm 16.2
	(min, max)	(20, 88)
Sex:		
Male	n/N (%)	74/170 (43.5%)
Female	n/N (%)	96/170 (56.5%)
Race:		
American Indian or Alaska Native	n/N (%)	1/170 (0.6%)
Asian	n/N (%)	5/170 (2.9%)
Black or African American	n/N (%)	20/170 (11.8%)
Native Hawaiian or Pacific Islander	n/N (%)	1/170 (0.6%)
White	n/N (%)	127/170 (74.7%)
White African	n/N (%)	1/170 (0.6%)
Latin American	n/N (%)	1/170 (0.6%)
Not Answered	n/N (%)	14/170 (8.2%)
Ethnicity*		
Hispanic or Latino	n/N (%)	13/154 (8.4%)
Not Hispanic or Latino	n/N (%)	141/154 (91.6%)
Chronic non-malignant obstruction present in:		
Left Leg	n/N (%)	145/170 (85.3%)
Right Leg	n/N (%)	24/170 (14.1%)
Both Legs	n/N (%)	1/170 (0.6%)
CEAP Assessment:		
0 (No visible or palpable signs of venous disease, only symptoms)	n/N (%)	2/170 (1.2%)
1 (Telangiectasia or reticular veins)	n/N (%)	0/170 (-)
2 (Varicose Veins)	n/N (%)	2/170 (1.2%)
3 (Oedema)	n/N (%)	45/170 (26.5%)
4 (Skin changes ascribed to venous disease (e.g., pigmentation, venous eczema, lipodermatosclerosis))	n/N (%)	78/170 (45.9%)
5 (Skin changes as defined above with healed ulceration)	n/N (%)	22/170 (12.9%)
6 (Skin changes as defined above with active ulceration)	n/N (%)	21/170 (12.4%)
VCSS Leg Pain (Target Limb)†		
Absent	n/N (%)	15/146 (10.3%)
Mild	n/N (%)	35/146 (24.0%)
Moderate	n/N (%)	54/146 (37.0%)
Severe	n/N (%)	42/146 (28.8%)

* Sixteen subjects from two sites did not provide their ethnicity per the policy at each site.

† Results for 24 subjects from one site are not included.

A large proportion of the VIRTUS subjects with prior thromboembolic disease reported a history of deep vein thrombosis, 119/130 (91.5%). A history of diabetes was reported by 29/170 (17.1%) of subjects and 62/170 (36.5%) were current or former smokers. Other frequently reported medical histories included: hypertension 68/170 (40%), allergies 60/170 (35.3%), and pulmonary embolism 28/130 (21.5%). A summary of the VIRTUS subjects' medical history results is provided in **Table 3**.

Table 3. Medical History, All Subjects (N=170)

Medical History	Subject Count n/N (%)
Diabetic	29/170 (17.06%)
Smoking History:	
Current Smoker	21/170 (12.35%)
Former Smoker	41/170 (24.12%)
Non-Smoker	108/170 (63.53%)
History of:	
Thromboembolic Disease	130/170 (76.5%)
Pulmonary Embolism*	28/130 (21.54%)
Deep Vein Thrombosis*	119/130 (91.54%)
CAD	14/170 (8.24%)
MI within past 5 years	1/170 (0.59%)
CABG	4/170 (2.35%)
PTCA/Stent	4/170 (2.35%)
CHF	4/170 (2.35%)
HTN	68/170 (40.00%)
Hepatic Disease	5/170 (2.94%)
Renal Disease	8/170 (4.71%)
PVD	29/170 (17.06%)
Coagulation Disorder	23/170 (13.53%)
CVA	10/170 (5.88%)
Cancer	18/170 (10.59%)
Recent Trauma	3/170 (1.76%)
Allergies	60/170 (35.29%)

The VICI stent was successfully implanted in all 170 VIRTUS pivotal cohort subjects. **Table 4** summarizes the VICI stent implant procedure parameters. The VICI stent implant procedure was performed using intravenous sedation for the majority of subjects, 109/170 (64.1%) and using general anesthesia for the remaining subjects. Nearly all procedures were performed using an ipsilateral antegrade approach, 166/170 (97.6%) with access obtained using the femoral vein 148/170 (87.1%). Pre-dilatation was performed in 109/170 (64.1%) of the cases and post-dilatation was performed in 154/170 (90.6%) of the cases. One VICI stent was placed in 85/170 (50%) of the cases, two VICI stents were placed in 62/170 (36.5%) of the cases, three VICI stents were placed in 20/170 (11.8%) of the cases, and four VICI stents were placed in 3/170 (1.8%) of the cases.

Table 4. Implant Procedure Parameters, All Subjects (N=170)

Parameter	Category	n/N (%)
Sedation Type	IV Sedation	109/170 (64.1%)
	General	61/170 (35.9%)
Puncture Type	Ipsilateral Anterograde	166/170 (97.6%)
	Contralateral Retrograde/Crossover	4/170 (2.4%)
Access Approach	Femoral	148/170 (87.1%)
	Popliteal	15/170 (8.8%)
	Jugular	4/170 (2.4%)
	Both	3/170 (1.8%)
Dilatation	Pre-Implant	109/170 (64.1%)
	Post-Implant	154/170 (90.6%)
Number of VICI Stents Placed Per Subject	1 stent	85/170 (50%)
	2 stents	62/170 (36.5%)
	3 stents	20/170 (11.8%)
	4 stents	3/170 (1.8%)

Table 5 provides a summary of the VICI stent sizes that were implanted per subject and the sizes of the VICI stents implanted for the pivotal cohort of the VIRTUS study. A total of 281 VICI stents were implanted in 170 subjects in the VIRTUS pivotal cohort.

Table 5: VICI Stent Sizes Utilized – Pivotal Cohort

Diameter	Length		
	60mm	90mm	120mm
12mm	3	2	4
14mm	10	26	44
16mm	29	43	120

Primary Safety Endpoint: The primary safety performance goal of freedom from MAEs in the VIRTUS study was 94%. As presented in **Table 6**, the number of subjects free from an MAE at 30 days was 167/169 (98.8%) with a 95% two-sided exact confidence limit of 95.8% to 99.9%. Since the lower confidence limit lies above the safety Performance Goal, the primary safety endpoint was successfully demonstrated.

There were no deaths or CEC-adjudicated UADEs reported in the VIRTUS study through the Month 12 follow-up.

Table 6. Summary of Major Adverse Events

MAE Criteria	Failures n/N (%) N=169*
Major adverse events (MAE) within 30 days*	2/169 (1.2%)
Device or procedure-related death	0/169 (0%)
Device or procedure-related bleeding requiring surgical or endovascular intervention or blood transfusion \geq 2 units	0/169 (0%)

MAE Criteria	Failures n/N (%) N=169*
Device or procedure-related arterial or venous injury requiring surgical or endovascular intervention	2/169 (1.2%)
Device or procedure-related acute DVT outside the target vein segment	0/169 (0%)
Clinically significant pulmonary embolism	0/169 (0%)
Embolization within stent	0/169 (0%)

*Safety data through 30 days post-procedure were available for 169/170 of the VIRTUS pivotal subjects as one subject never returned for follow-up after discharge.

Primary Effectiveness Endpoint: The primary effectiveness endpoint of patency at 12 months for the VIRTUS study was met with 84% of the subjects patent, compared to the effectiveness Performance Goal of 72.1%, $p < 0.0001$. The patency results at Month 12 are provided in **Table 7**. The combined p-value of the comparisons to the primary effectiveness Performance Goal is less than the study specified α level for success of 0.025, therefore the primary effectiveness endpoint for the study was successfully achieved. The VICI VENOUS STENT met the Performance Goal which was developed from results reported in the literature for previous studies of iliofemoral stenting. These patency results were also confirmed using Duplex Ultrasound (DUS) and intravascular ultrasound (IVUS) imaging, where similar patency results were obtained.

Table 7. Primary Effectiveness Endpoints, All Subjects (N=170)

Proportion of Subjects at Month 12	Combined SE	t-statistic	p-value
84.0%	2.8%	4.0	<0.0001

The performance of the VICI stent for the NT and PT populations, based on the Completed Cases analysis, compare favorably to the estimated performance based on the literature, 96.2% for the NT subjects (compared to 95.5% from the literature) and 79.8% for the PT subjects (compared to 77.6% from the literature). The results are provided in Error! Reference source not found..

Table 8. Completed Cases Effectiveness Analysis

Overall Success n/N (%)	NT Subject Success n/N (%)	PT Subject Success n/N (%)	Combined Success Proportion *	Combined SE	t-statistic	p-value
104/125 (83.2%)	25/26 (96.2%)	79/99 (79.8%)	83.9%	3.2%	3.72	0.0002

*Derived from a weighted average of the NT and PT populations.

Among the 170 pivotal subjects, 125 had a known patency outcome, 99 in the PT sub-population and 26 in the NT sub-population. Sixteen (16) subjects had a qualifying Target Vessel Revascularization (TVR), as adjudicated by the VIRTUS Clinical Events Committee (CEC). Seventy-nine (79) subjects had a venogram result within the Month 12 window assessed by the Venography Core Laboratory.

Thirty (30) subjects were missing the result for their Month 12 venogram but had a venogram demonstrating patency as assessed by the Venography Core Laboratory that was beyond the upper limit of the Month 12 visit window.

There were 45 subjects (28 PT, 17 NT) that did not have a known patency outcome at Month 12. Among the 45 subjects, 7 withdrew prior to Month 12, 4 missed the Month 12 Visit, and 34 did not have venography at Month 12 Visit but remained in the study. These 45 subjects had their patency status imputed as described in the Statistical Analysis Report. The imputation was performed 15 times and the results were compared to the primary effectiveness Performance Goal of 72.1% that had been previously established.

Primary Patency Failures: There was a total of 21 pivotal cohort subjects who were primary effectiveness failures due to patency issues or qualifying TVRs. There were 16 subjects that had one or more qualifying TVRs within the first 12-months, as adjudicated by the VIRTUS CEC. An additional 5 subjects had greater than 50% stenosis, based on their Month 12 venogram assessment by the Venography Core Laboratory.

Additional Imaging Results (DUS and IVUS)

Per the VIRTUS protocol and the SAP, venography was the imaging modality used to determine patency at Month 12 for the primary effectiveness endpoint. Two additional imaging modalities were utilized as part of the VIRTUS study, duplex ultrasound (DUS) and intravascular ultrasound (IVUS). Both imaging modalities were performed at Month 12 and the images were assessed by independent Core Laboratories.

Although analyses of these additional imaging modalities were not pre-specified in the protocol or in the SAP, the primary patency endpoint was analyzed in a post-hoc fashion using additional data from the DUS and IVUS images following Core Laboratory adjudication. In addition, the IVUS images were also analyzed for the percentage area stenosis by the IVUS Core Laboratory. Since the definition of patency used for the primary effectiveness endpoint would not necessarily apply to the area of stenosis, these results at Month 12 are presented descriptively. These additional imaging analyses are being provided for informational and comparative purposes.

For subjects with an unknown patency outcome, the result beyond Day 425 was used to define the subject as a success if there was <50% stenosis and the subject had not had a prior qualifying TVR.

There were 133 subjects for whom their Month 12 patency outcome could be determined by DUS. The results for these subjects are provided in **Table 9**. The estimated patency rate based on DUS was 83.5% (combined success proportion), which is similar to the result for the Completed Cases as determined by venogram (83.9%). The lower 95% confidence limit for the combined success proportion was 76.0%.

There were 120 subjects that had a patency outcome that could be determined by IVUS segment diameter. The results for these subjects are provided in **Table 9**. The estimated patency rate based on IVUS diameter was 80.1% (combined success proportion), which is similar to the result reported for the Completed Cases as determined by

venogram (83.9%). The lower 95% confidence limit for the combined success proportion was 70.8%.

Table 9: Month 12 Patency Result Based on DUS and IVUS

Imaging Modality	Overall Success n/N (%) [*]	NT Subject Success n/N (%)	PT Subject Success n/N (%)
DUS ¹	111/133 (83.5%)	33/35 (94.3%)	78/98 (79.6%)
IVUS	95/120 (79.2%)	24/25 (96.0%)	71/95 (74.7%)

¹Based on subjects with core lab evaluable DUS at or beyond the Month 12 interval or prior qualifying TVR as of November 1, 2018.

^{*}Derived from a weighted average of the NT and PT populations.

IVUS Stenosis Result Based on Segment Areas

There were no pre-defined patency criteria based on the IVUS percent area stenosis computed by the IVUS Core Laboratory. Since patency by IVUS had not been defined, a descriptive summary of the IVUS percent area stenosis at Month 12 was computed. Subjects that had a qualifying TVR, as determined by the CEC, prior to Day 425 were excluded from this descriptive summary. For subjects without a qualifying TVR, the maximum percent area stenosis within the Month 12 window (Days 305 to 425) among the three segments, EIV, CIV and CFV, based on the IVUS Core Laboratory assessment was analyzed. If there was no result available within the Month 12 window, a percentage area stenosis beyond Day 425 was used for the analysis if available.

There were 106 subjects that had a Month 12 percentage stenosis area computed by the IVUS Core Laboratory. The results for these subjects are provided in **Table 10**. The mean (SD) maximum percentage stenosis at Month 12 based on the IVUS images is 35.6% (19.4%).

Table 10: Month 12 Maximum Percentage Stenosed Based on IVUS Areas

Parameter	Month 12 Stenosis
N	106
Mean (SD)	35.6% (19.4%)
Median (Min, Max)	32.5% (3.2%, 78.8%)
95% Confidence Interval	[31.9%; 39.3%]

Secondary and Other Effectiveness Endpoints: There were 49.2% of the subjects (65/132) that reported an improvement of 50% or more in their Month 12 VCSS score relative to baseline. (Note that data from one US center, affecting 24 subjects, were specifically excluded because the information could not be verified as accurate.) This result failed to meet the success criteria for the secondary effectiveness endpoint for VCSS since the lower limit of the 95% exact confidence interval falls below the stated Performance Goal of 50%. For the CIVIQ-20 assessment, the score improved by 13.1 points at Month

12 compared to baseline and 77/133 (57.9%) of the subjects had a decrease in score of 9 points or more. For the subject-reported VAS pain score, 60 of the 133 subjects (45.1%) with Month 12 results reported an improvement (decrease) in their pain score of 20 points or more.

Secondary patency was defined as freedom from “permanent” loss of patency determined through last follow-up (irrespective of the number of interventions). This endpoint also required a 12-month or later Venography Core Laboratory assessment. The rate of secondary patency at Month 12 was 119/121 (98.4%) with 95% confidence limits of 94.2% to 99.8%.

Estimate Primary-Assisted Patency

Primary-assisted patency was defined as freedom from occlusion regardless of whether an intervention (subsequent to the index procedure) was performed. This endpoint also required a 12-month or later Venography Core Laboratory assessment, but a complete occlusion any time during the study was considered a failure. There were 126 subjects with either a Month 12 core lab assessed venogram within the Month 12 visit window, or 100% occlusion via core lab assessed venogram at any point during the first 12 months, or a Month 12 core lab assessed venogram that was after the Month 12 visit window but was < 100% stenosed. The rate of primary-assisted patency was 117/126 (92.9%).

Estimate Secondary Patency

Secondary patency was defined as freedom from “permanent” loss of patency determined through last follow-up (irrespective of the number of interventions). This endpoint also required a 12-month or later Venography Core Laboratory assessment. There were 121 subjects with either a Month 12 core lab assessed venogram in-window or Month 12 core lab assessed venogram that was after the Month 12 visit window but was < 100% stenosed. The rate of secondary patency was 119/121 (98.4%).

Procedure Technical Success

Procedural technical success is defined as any subject without a post procedural residual stenosis greater than 50% that had adequate stent overlap and with placement of the study device alone. This endpoint is based on the presence of a Venography Core Laboratory assessment of the post-procedural venogram. Four subjects did not have a post-procedural venographic image; therefore, procedure technical success was evaluated in 166 subjects. There were two subjects who failed procedure technical success due to the use of non-study stents. The number of subjects with procedural technical success was 164/166 (98.8%).

Lesion Success

Lesion success is defined as any subject without a post procedural residual stenosis greater than 50%. This endpoint is based on the presence of a Venography Core Laboratory assessment of the post-procedural venogram. Four subjects did not have a post-procedural venographic image; therefore, lesion success was evaluated in 166 subjects. The rate of lesion success was 166/166 (100%). The difference between procedural technical success and lesion success

was the use of non-study stents, which was not considered a failure for lesion success.

Procedural Success

Procedural success is defined as any subject with procedural technical success without an MAE. As with the two analyses above, procedural success depends on the Venography Core Laboratory assessment of the post-procedure venogram. Four subjects did not have a post-procedural venographic image; therefore, procedural success was evaluated in 166 subjects. There were two subjects who failed procedural success due to the use of non-study stents (see procedural technical success) and two subjects who failed due to a MAE. Thus, the rate of procedural success was 162/166 (97.6%).

Late Technical Success

Late technical success is defined as subjects without a qualifying TVR as adjudicated by the VIRTUS CEC, a Month 12 restenosis greater than 50%, a stent compression or a stent fracture. Late technical success was evaluated at 12 months and the results were based on a 12-month (or later if demonstrating patency) venogram, a reintervention for complete occlusion prior to 12-months or an X-Ray Core Laboratory confirmed stent fracture. There were 127 subjects with a 12-month venogram and/or stent fracture assessment. There were 30 subjects who were considered to be a failure for late technical success. Sixteen (16) of these subjects had a qualifying TVR, 5 subjects were not considered patent at Month 12 and 9 subjects had a stent fracture. One subject who had a TVR also had a stent fracture; this subject is accounted for in the qualifying TVRs. The rate of late technical success was 97/127 (76.4%).

Change in the Quality of Life (CIVIQ-20)

The CIVIQ-20 results were analyzed as the change from Baseline at 12 months for the VIRTUS pivotal cohort. This instrument is scored from 20 to 100 points with lower scores indicating a lesser impact on health. **Table 11** provides the available CIVIQ-20 results from Baseline, 12-month and the 12-month change from Baseline.

Table 11: CIVIQ-20 Results – Pivotal Cohort

Visit	Parameter	CIVIQ-20 Global Score
Screen/Baseline	N	146*
	Mean ± SD	55.4 ± 19.40
	95% CI	[52.2; 58.5]
	Median (Min, Max)	53 (20, 98)
Month 12	N	133†
	Mean ± SD	41.7 ± 20.05
	95% CI	[38.3; 45.2]

Visit	Parameter	CIVIQ-20 Global Score
	Median (Min, Max)	35 (20, 98)
Month 12 Change from Screen/Baseline	N	133†
	Mean ± SD	-13.1 ± 18.56
	95% CI	[-16.3; -10.0]
	Median (Min, Max)	-12 (-72, 32)

* Results for 24 subjects from a single US center are not included. Please refer to section B for more details.

† In addition to the above data that is not included, 11 subjects did not have a Month 12 visit and 2 subjects did not complete the CIVIQ forms.

In addition to the summary of the results, a summary of the responders, where a decrease of 9 or more is considered a responder, was also performed. Seventy-seven (77) of the 133 subjects with Month 12 results had a decrease in score of 9 or more, indicating that over 57% (57.9%) of the subjects treated in the VIRTUS pivotal cohort had a clinically significant improvement in their quality of life.

Subgroup Analyses

The primary effectiveness endpoint was evaluated for differences by gender and are provided in **Table 12**. There was no significant difference in patency rates between genders.

Table 12: Primary Patency by Gender

Gender	Patent	Not Patent	p-value ^a
Female	57/66 (86.36%)	9/66 (13.64%)	0.3467
Male	47/59 (79.66%)	12/59 (20.34%)	
Total	104	21	

^a Two-sided Fisher's exact test

Secondary Safety Analysis: The secondary safety analysis was descriptive summaries of all adverse events reported for the VIRTUS study. The site-reported Serious Adverse Events and Adverse Events were tabulated by MedDRA System Organ Classification (SOC) and within the SOC by the MedDRA Preferred Term through Month 12 for all VIRTUS subjects (N=170). The overall SAE results are provided in **Table 13**, which presents the number and proportion of subjects reporting one or more Events within a category, as well as the actual number of individual Events reported. Adverse events that were considered device or procedure related are provided in

Table 14.

Table 13: Rates of Site-Reported Serious Adverse Events to 425 Days Intent-to-Treat, All Subjects (N=170)

MedDRA System Organ Classification	Rate of Subjects with Event n (%) [95% CI]
SOC: Blood and lymphatic system disorders (Events=5)	4 (2.4%) [0.6%;5.9%]
Anaemia (Events=1)	1 (0.6%) [0.0%;3.2%]
Sickle cell anaemia with crisis (Events=1)	1 (0.6%) [0.0%;3.2%]
Thrombocytopenia (Events=1)	1 (0.6%) [0.0%;3.2%]
Haemorrhagic anaemia (Events=1)	1 (0.6%) [0.0%;3.2%]
White blood cell disorder (Events=1)	1 (0.6%) [0.0%;3.2%]

MedDRA System Organ Classification	Rate of Subjects with Event n (%) [95% CI]
SOC: Cardiac disorders (Events=9)	7 (4.1%) [1.7%;8.3%]
Acute myocardial infarction (Events=2)	2 (1.2%) [0.1%;4.2%]
Bradycardia (Events=1)	1 (0.6%) [0.0%;3.2%]
Cardiac failure congestive (Events=1)	1 (0.6%) [0.0%;3.2%]
Pericardial effusion (Events=1)	1 (0.6%) [0.0%;3.2%]
Ventricular tachycardia (Events=1)	1 (0.6%) [0.0%;3.2%]
Atrial fibrillation (Events=3)	1 (0.6%) [0.0%;3.2%]
SOC: Gastrointestinal disorders (Events=4)	3 (1.8%) [0.4%;5.1%]
Gastric perforation (Events=1)	1 (0.6%) [0.0%;3.2%]
Ileus (Events=1)	1 (0.6%) [0.0%;3.2%]
Melaena (Events=1)	1 (0.6%) [0.0%;3.2%]
Rectal haemorrhage (Events=1)	1 (0.6%) [0.0%;3.2%]
SOC: General disorders and administration site conditions (Events=24)	18 (10.6%) [6.4%;16.2%]
Vascular stent thrombosis (Events=13)	9 (5.3%) [2.4%;9.8%]
Vascular stent restenosis (Events=3)	3 (1.8%) [0.4%;5.1%]
Vascular stent occlusion (Events=2)	2 (1.2%) [0.1%;4.2%]
Vascular stent stenosis (Events=2)	2 (1.2%) [0.1%;4.2%]
Oedema peripheral (Events=1)	1 (0.6%) [0.0%;3.2%]
Peripheral swelling (Events=1)	1 (0.6%) [0.0%;3.2%]

MedDRA System Organ Classification	Rate of Subjects with Event n (%) [95% CI]
Puncture site haemorrhage (Events=1)	1 (0.6%) [0.0%;3.2%]
Stenosis (Events=1)	1 (0.6%) [0.0%;3.2%]
SOC: Infections and infestations (Events=6)	5 (2.9%) [1.0%;6.7%]
Sepsis (Events=3)	3 (1.8%) [0.4%;5.1%]
Cellulitis (Events=1)	1 (0.6%) [0.0%;3.2%]
Parotitis (Events=1)	1 (0.6%) [0.0%;3.2%]
Urinary tract infection (Events=1)	1 (0.6%) [0.0%;3.2%]
SOC: Injury, poisoning and procedural complications (Events=4)	4 (2.4%) [0.6%;5.9%]
Hip fracture (Events=1)	1 (0.6%) [0.0%;3.2%]
Wound (Events=1)	1 (0.6%) [0.0%;3.2%]
Post procedural haematoma (Events=1)	1 (0.6%) [0.0%;3.2%]
Delayed haemolytic transfusion reaction (Events=1)	1 (0.6%) [0.0%;3.2%]
SOC: Investigations (Events=3)	2 (1.2%) [0.1%;4.2%]
Blood culture positive (Events=1)	1 (0.6%) [0.0%;3.2%]
Haemoglobin decreased (Events=1)	1 (0.6%) [0.0%;3.2%]
Specific gravity urine abnormal (Events=1)	1 (0.6%) [0.0%;3.2%]
SOC: Metabolism and nutrition disorders (Events=1)	1 (0.6%) [0.0%;3.2%]
Diabetic ketoacidosis (Events=1)	1 (0.6%) [0.0%;3.2%]
SOC: Musculoskeletal and connective tissue disorders (Events=7)	7 (4.1%) [1.7%;8.3%]

MedDRA System Organ Classification	Rate of Subjects with Event n (%) [95% CI]
Back pain (Events=3)	3 (1.8%) [0.4%;5.1%]
Pain in extremity (Events=2)	2 (1.2%) [0.1%;4.2%]
Arthralgia (Events=1)	1 (0.6%) [0.0%;3.2%]
Rhabdomyolysis (Events=1)	1 (0.6%) [0.0%;3.2%]
SOC: Nervous system disorders (Events=7)	4 (2.4%) [0.6%;5.9%]
Seizure (Events=2)	2 (1.2%) [0.1%;4.2%]
Cerebral haemorrhage (Events=1)	1 (0.6%) [0.0%;3.2%]
Cerebrovascular accident (Events=1)	1 (0.6%) [0.0%;3.2%]
Encephalopathy (Events=1)	1 (0.6%) [0.0%;3.2%]
Sciatica (Events=1)	1 (0.6%) [0.0%;3.2%]
Encephalomalacia (Events=1)	1 (0.6%) [0.0%;3.2%]
SOC: Psychiatric disorders (Events=1)	1 (0.6%) [0.0%;3.2%]
Mental status changes (Events=1)	1 (0.6%) [0.0%;3.2%]
SOC: Renal and urinary disorders (Events=3)	2 (1.2%) [0.1%;4.2%]
Acute kidney injury (Events=2)	2 (1.2%) [0.1%;4.2%]
Chronic kidney disease (Events=1)	1 (0.6%) [0.0%;3.2%]
SOC: Respiratory, thoracic and mediastinal disorders (Events=4)	4 (2.4%) [0.6%;5.9%]
Pulmonary embolism (Events=2)	2 (1.2%) [0.1%;4.2%]
Respiratory depression (Events=1)	1 (0.6%) [0.0%;3.2%]

MedDRA System Organ Classification	Rate of Subjects with Event n (%) [95% CI]
Respiratory failure (Events=1)	1 (0.6%) [0.0%;3.2%]
SOC: Skin and subcutaneous tissue disorders (Events=2)	2 (1.2%) [0.1%;4.2%]
Skin ulcer (Events=2)	2 (1.2%) [0.1%;4.2%]
SOC: Surgical and medical procedures (Events=27)	19 (11.2%) [6.9%;16.9%]
Venous angioplasty (Events=8)	7 (4.1%) [1.7%;8.3%]
Thrombolysis (Events=4)	4 (2.4%) [0.6%;5.9%]
Varicose vein operation (Events=4)	4 (2.4%) [0.6%;5.9%]
Vascular stent insertion (Events=2)	2 (1.2%) [0.1%;4.2%]
Angioplasty (Events=1)	1 (0.6%) [0.0%;3.2%]
Cholecystectomy (Events=1)	1 (0.6%) [0.0%;3.2%]
Hip arthroplasty (Events=1)	1 (0.6%) [0.0%;3.2%]
Myomectomy (Events=1)	1 (0.6%) [0.0%;3.2%]
Thrombectomy (Events=1)	1 (0.6%) [0.0%;3.2%]
Hernia repair (Events=1)	1 (0.6%) [0.0%;3.2%]
Venous stent insertion (Events=1)	1 (0.6%) [0.0%;3.2%]
Transfusion (Events=1)	1 (0.6%) [0.0%;3.2%]
Interventional procedure (Events=1)	1 (0.6%) [0.0%;3.2%]
SOC: Vascular disorders (Events=26)	19 (11.2%) [6.9%;16.9%]
Deep vein thrombosis (Events=12)	8 (4.7%) [2.1%;9.1%]

MedDRA System Organ Classification	Rate of Subjects with Event n (%) [95% CI]
Arteriovenous fistula (Events=2)	2 (1.2%) [0.1%;4.2%]
Aortic aneurysm (Events=1)	1 (0.6%) [0.0%;3.2%]
Varicose ulceration (Events=1)	1 (0.6%) [0.0%;3.2%]
Varicose vein (Events=1)	1 (0.6%) [0.0%;3.2%]
Vena cava thrombosis (Events=1)	1 (0.6%) [0.0%;3.2%]
Venous thrombosis (Events=1)	1 (0.6%) [0.0%;3.2%]
Venous stenosis (Events=1)	1 (0.6%) [0.0%;3.2%]
Paget-Schroetter syndrome (Events=1)	1 (0.6%) [0.0%;3.2%]
Venous occlusion (Events=1)	1 (0.6%) [0.0%;3.2%]
Vascular compression (Events=1)	1 (0.6%) [0.0%;3.2%]
Peripheral venous disease (Events=1)	1 (0.6%) [0.0%;3.2%]
Phlebitis (Events=2)	1 (0.6%) [0.0%;3.2%]
SOC: Product issues (Events=6)	6 (3.5%) [1.3%;7.5%]
Device dislocation (Events=3)	3 (1.8%) [0.4%;5.1%]
Stent malfunction (Events=2)	2 (1.2%) [0.1%;4.2%]
Device occlusion (Events=1)	1 (0.6%) [0.0%;3.2%]

Table 14: Rates of Site-Reported Device or Procedure Related Adverse Events to 425 Days Intent-to-Treat, All Subjects (N=170)

MedDRA System Organ Classification	Rate of Subjects with Event n (%) [95% CI]
SOC: General disorders and administration site conditions (Events = 16)	15 (8.8%) [5.0%; 14.1%]
Vascular stent thrombosis (Events = 4)	4 (2.4%) [0.6%; 5.9%]
Peripheral swelling (Events = 4)	4 (2.4%) [0.6%; 5.9%]
Vascular stent occlusion (Events = 3)	3 (1.8%) [0.4%;5.1%]
Puncture site hemorrhage (Events = 1)	1 (0.6%) [0.0%; 3.2%]
Vascular stent stenosis (Events = 2)	2 (1.2%) [0.1%; 4.2%]
Localized oedema (Events = 1)	1 (0.6%) [0.0%; 3.2%]
Vascular stent restenosis (Events = 1)	1 (0.6%) [0.0%; 3.2%]
SOC: Injury, poisoning and procedural complications (Events = 4)	4 (2.4%) [0.6%; 5.9%]
Fall (Events = 1)	1 (0.6%) [0.0%; 3.2%]
Post procedural constipation (Events = 1)	1 (0.6%) [0.0%; 3.2%]
Vascular access site hemorrhage (Events = 1)	1 (0.6%) [0.0%; 3.2%]
Vascular access site pain (Events = 1)	1 (0.6%) [0.0%; 3.2%]
SOC: Investigations (Events = 2)	1 (0.6%) [0.0%; 3.2%]
Blood creatinine increased (Events = 1)	1 (0.6%) [0.0%; 3.2%]
Oxygen saturation decreased (Events = 1)	1 (0.6%) [0.0%; 3.2%]
SOC: Metabolism and nutrition disorders (Events = 2)	2 (1.2%) [0.1%; 4.2%]

MedDRA System Organ Classification	Rate of Subjects with Event n (%) [95% CI]
Dehydration (Events = 1)	1 (0.6%) [0.0%; 3.2%]
Hyperglycemia (Events = 1)	1 (0.6%) [0.0%; 3.2%]
SOC: Musculoskeletal and connective tissue disorders (Events = 17)	14 (8.2%) [4.6%;13.4%]
Back pain (Events = 11)	10 (5.9%) [2.9%;10.6%]
Pain in extremity (Events = 3)	3 (1.8%) [0.4%;5.1%]
Arthralgia (Events = 1)	1 (0.6%) [0.0%;3.2%]
Groin pain (Events = 1)	1 (0.6%) [0.0%;3.2%]
Musculoskeletal chest pain (Events = 1)	1 (0.6%) [0.0%;3.2%]
SOC: Psychiatric disorders (Events = 1)	1 (0.6%) [0.0%; 3.2%]
Drug use disorder (Events = 1)	1 (0.6%) [0.0%; 3.2%]
SOC: Renal and urinary disorders (Events = 1)	1 (0.6%) [0.0%; 3.2%]
Acute kidney injury (Events = 1)	1 (0.6%) [0.0%; 3.2%]
SOC: Reproductive system and breast disorders (Events = 1)	1 (0.6%) [0.0%; 3.2%]
Scrotal pain (Events = 1)	1 (0.6%) [0.0%; 3.2%]
SOC: Surgical and medical procedures (Events = 4)	4 (2.4%) [0.6%; 5.9%]
Thrombolysis (Events = 1)	1 (0.6%) [0.0%; 3.2%]
Varicose vein operation (Events = 1)	1 (0.6%) [0.0%; 3.2%]
Vascular stent insertion (Events = 1)	1 (0.6%) [0.0%; 3.2%]
Venous stent insertion (Events = 1)	1 (0.6%) [0.0%; 3.2%]

MedDRA System Organ Classification	Rate of Subjects with Event n (%) [95% CI]
SOC: Vascular disorders (Events = 8)	8 (4.7%) [2.1%; 9.1%]
Hematoma (Events = 2)	2 (1.2%) [0.1%;4.2%]
Deep vein thrombosis (Events = 2)	2 (1.2%) [0.1%; 4.2%]
Hypotension (Events = 1)	1 (0.6%) [0.0%; 3.2%]
Peripheral coldness (Events = 1)	1 (0.6%) [0.0%; 3.2%]
Hemorrhage (Events = 1)	1 (0.6%) [0.0%; 3.2%]
Peripheral venous disease (Events = 1)	1 (0.6%) [0.0%; 3.2%]
SOC: Product issues (Events = 2)	2 (1.2%) [0.1%; 4.2%]
Device dislocation (Events = 1)	1 (0.6%) [0.0%; 3.2%]
Stent malfunction (Events = 1)	1 (0.6%) [0.0%; 3.2%]

Access Site Related Adverse Events: In the VIRTUS study, there were 13 adverse events in 12 subjects that were related to the access site, either during the index procedure or for a follow-up procedure. The overall access site-related adverse event rate was 7% (12/170). The type of reported access site events was within expectation, with hematoma with and without pseudoaneurysm being the most common access site event.

Stent Fractures: A total of 10 subjects (10/170 = 5.9%) had stent fractures as confirmed by the independent X-Ray Core Laboratory. The overall stent fracture rate was 10/281 (3.6%) for the total number of implanted stents. There was 1 Type I fracture, 8 Type II fractures, and 1 Type IV fracture. The fractures did not appear to have an impact on patency, as the fractured stents for all 10 subjects were patent at the Month 12 visit. None of the subjects experienced symptoms that were related to their stent fractures and no interventions were required as a result of the stent fractures. 9 of the 10 fractures occurred in the common femoral vein of PT subjects and 1 fracture occurred in the common iliac vein of an NT subject. None of the fractures occurred within overlapped areas of the stents.

CONCLUSION: The results for the VIRTUS study met both the primary effectiveness and primary safety endpoints; therefore, establishing the effectiveness and safety of the VICI VENOUS STENT System for

improving luminal diameter in the iliofemoral veins for the treatment of symptomatic venous outflow obstruction.

HOW SUPPLIED

Handling and Storage

- Do not use if package is opened or damaged. Contact your Boston Scientific representative.
- Do not use if package label is incomplete or illegible. Contact your Boston Scientific representative.
- Store in a dry, cool place at room temperature.

RECOMMENDED MATERIALS

Additional items that may be required for this procedure are as follows:

- 9F introducer sheath
- 0.035in guidewire
- Large diameter, non-compliant, high-pressure balloon
- Sterile syringe with luer lock for flushing lumens
- Sterile heparinized saline

OPERATIONAL INSTRUCTIONS

Procedure

Only physicians who have received appropriate training in the principles, clinical applications, complications, side effects, and hazards commonly associated with interventional vascular procedures should use this device.

Table 15. Stent Foreshortening Information

Fully Open Dimension (per label on box)		Nominal Vessel Diameter and Approximate Implanted Stent Length*					
Stent O.D. (mm)	Stent Length (mm)	Nominal Vessel Diameter (mm)	Stent Length (Average) (mm)	Nominal Vessel Diameter (mm)	Stent Length (Average) (mm)	Nominal Vessel Diameter (mm)	Stent Length (Average) (mm)
12	60	9	66	10	64	11	62
12	90	9	100	10	96	11	93
12	120	9	134	10	129	11	124
14	60	11	65	12	63	13	61
14	90	11	99	12	95	13	92
14	120	11	129	12	127	13	125
16	60	12	65	14	63	15	61
16	90	12	98	14	95	15	92
16	120	12	131	14	127	15	122

*Data based on average measurements from simulated use testing in an anatomical model.

Patient Preparation

The percutaneous placement of an iliofemoral self-expanding nitinol stent should be done in a fluoroscopy procedure room equipped with the appropriate imaging equipment. Patient preparation and sterile precautions should be the same as for any endovascular procedure. Appropriate anticoagulation therapy must be administered pre-, peri- and post-procedure in accordance with standard practices.

Venography and intravascular ultrasound should be performed to identify and assess the access veins, collateral veins, lesion characteristics and peripheral inflow. Access veins must be sufficiently patent to proceed with further intervention. If thrombus is present or suspected, thrombolysis should precede stent placement using standard acceptable practice.

Step 1-Obtain Access

- Prepare, drape, and anesthetize the skin puncture site in standard manner.
- Obtain access under ultrasound guidance using either the Seldinger technique or cutdown.
- Fluoroscopy and/or intravascular ultrasound should be used to identify and assess access veins, collateral veins, lesion characteristics, and peripheral inflow.

Step 2-Preparations for Use (Reference Figure 2)

- Observe the Nosecone of the Delivery System where it meets the Outer Shaft. If there is a gap the gap may be closed by pulling the Inner Shaft Hub proximally. To do this, loosen the Rotating Hemostasis Valve and gently pull the Inner Shaft Hub proximally until the gap is closed. Tighten the Rotating Hemostasis Valve.
- Ensure all luers are tightened.
- Flush the inner shaft lumen with sterile heparinized saline. Ensure the Rotating Hemostasis Valve is tightened.
- Flush outer shaft lumen with sterile heparinized saline. Close the stopcock when flushing of the outer shaft lumen is complete.

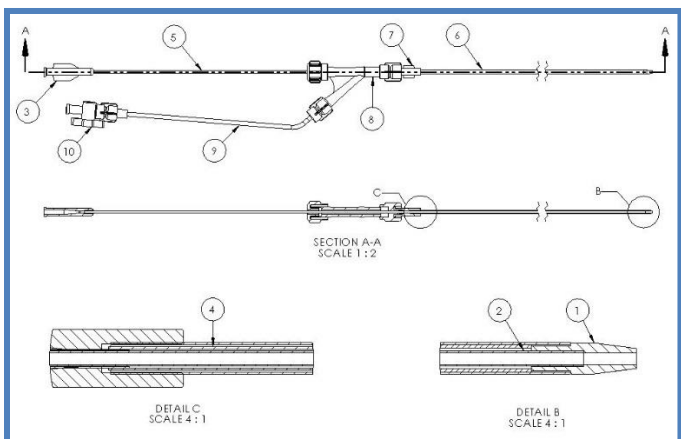

Figure 2: Illustration of Delivery System

The components of the Delivery System are identified below:

- | | |
|-----------------------|------------------------------|
| 1. Nosecone | 6. Outer Shaft |
| 2. Inner Shaft | 7. Outer Shaft Hub |
| 3. Inner Shaft Hub | 8. Rotating Hemostasis Valve |
| 4. Mid Shaft | 9. Extension Line |
| 5. Mid Shaft Hypotube | 10. 1-Way Stop Cock |

Step 3-Stent Selection

- Determine the length of the lesion and vessel diameter at the peripheral reference vein. When determining the reference vein diameter with venography, use multi-planar measurements. The stent diameter should be 1 - 2mm greater than (“over”) the measured diameter of the surrounding “normal” vein.
- In post-thrombotic diseased veins, target veins should be pre-dilated to the reference vein diameter.
- In non-thrombotic lesions, size stent diameter to ensure stent engagement in area of central focal compressive lesion (e.g., vessel crossing) and adequate wall apposition in peripheral normal veins.
- Dilated veins peripheral to focal stenosis are not normal veins, and therefore should not be used to measure reference vein diameter and stent diameter selection.
- Excessive oversizing of stents has been reported to contribute to post-operative patient pain.
- The stented length should be at least 1cm longer than the obstructive venous lesion (a minimum of 0.5cm centrally and 0.5cm peripherally).
- Pre-dilation of the target vein to the reference vein diameter is recommended prior to stent implantation.
- **Warning:** Failure to select appropriate stent length and diameter based on lesion and vessel characteristics could lead to migration and/or embolization.

Step 4-Stent Placement

- The following steps must be completed under fluoroscopic guidance:
 - Advance the guidewire past the target lesion to be treated.
 - Advance the introducer sheath over the guidewire into body.
 - Position the introducer sheath tip.
- Advance the Delivery System over the guidewire and into the introducer sheath until the leading marker band of the stent is approximately 0.5cm beyond the distal boundary of the lesion.
 - **Note:** *The distal end of the stent will deploy first.*
- Loosen the Rotating Hemostasis Valve.
 - **Note:** *Do not loosen the luer connection of the Rotating Hemostasis Valve to the Outer Shaft, as this will increase the difficulty or prevent stent deployment.*
- Firmly “pin” the Inner Shaft Hub and “pull” the Rotating Hemostasis Valve peripherally to deploy the stent.
 - **Note:** *The initial force to deploy larger diameter/longer length stents may be high. Initial deployment should be performed slowly to deploy first 2-3 stent strut rings.*
 - **Note:** *Physician should ensure Delivery System is positioned at desired stent placement site.*
 - **Note:** *Under fluoroscopic guidance, deploy remaining stent in a controlled and continuous motion.*
 - **Warning:** *Failure to maintain Delivery System **position** during stent deployment may lead to placement of the stent in an unintended site.*
- **Warning:** *Removal of the Delivery System should be performed under fluoroscopic guidance. If resistance is encountered, do not attempt to remove Delivery System until resistance is cleared.*











Step 5-Confirmation of Stent Placement

- Confirm that the stent is fully deployed and desired wall apposition is achieved by post-dilating the stent with a high-pressure balloon in the nominal diameter of the stent selected.
- If multiple stents will be placed, each stent should be post-dilated with a high-pressure balloon prior to placing additional stents.
- Overlapping stents: Ensure overlap of stents is at least 1cm. Stent lengths should be selected to avoid overlapping stents in the region of the inguinal ligament.
- Stent placement should be confirmed via venography to assess venous flow and lumen patency.

Product Disposal

After use, dispose of product and packaging in accordance with hospital, administrative, and/or local government policy.

DEFINITION OF SYMBOLS

SYMBOL	DESCRIPTION
	Do not use if packaging or product is damaged
	Contents supplied STERILE using an ethylene oxide (EO) process. Do not use if the sterile barrier is damaged.
	For Single Use Only. Do not reuse, reprocess, or resterilize the System
	Carefully read all instructions prior to use.
	Lot Number
	Catalog Number
	Contents
	Do not use the device after the “Use By” date specified on the package label.
	Magnetic Resonance Conditional
	Store in a cool, dry place
	Legal manufacturer

LIMITED WARRANTY

Boston Scientific Corporation (BSC) warrants that reasonable care has been used in the design and manufacture of this instrument. **This warranty is in lieu of and excludes all other warranties not expressly set forth herein, whether express or implied by operation of law or otherwise, including, but not limited to, any implied warranties of merchantability or fitness for a particular purpose.** Handling, storage, cleaning and sterilization of this instrument as well as other factors relating to the patient, diagnosis, treatment, surgical procedures and other matters beyond BSC's control directly affect the instrument and the results obtained from its use. BSC's obligation under this warranty is limited to the repair or replacement of this instrument and BSC shall not be liable for any incidental or consequential loss, damage or expense directly or indirectly arising from the use of this instrument. BSC neither assumes, nor authorizes any other person to assume for it, any other or additional liability or responsibility in connection with this instrument. **BSC assumes no liability with respect to instruments reused, reprocessed or resterilized and makes no warranties, express or implied, including but not limited to merchantability or fitness for a particular purpose, with respect to such instruments.**

Legal Manufacturer:

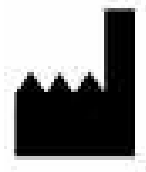

VENITI, Inc.
4025 Clipper Ct.
Fremont, CA 94538
USA
Tel: 1 888-272-1001

©2019 Boston Scientific Corporation or its affiliates. All rights reserved.

STE-IFU-005 Rev A Instructions for Use for the VICI VENOUS STENT System