

**US DFU**  
**Clareon™ Aspheric Hydrophobic Acrylic IOL with the AutonoMe™ Automated Pre-loaded Delivery System**  
**Model: CNA0T0**

NOTE: Text appearing in gray is for information purposes only.

Directions for Use

<Note: Include revision number and revision date on approved DFU>

 <https://ifu.alcon.com>

XX-XXX-XXX-XXX <Insert Commodity Number>

**PRODUCT INFORMATION**

Alcon Laboratories, Inc.

Clareon™ Aspheric Hydrophobic Acrylic IOL  
with the AutonoMe™ Automated Pre-loaded Delivery System (logo)

**STERILE UV and Blue Light Filtering Hydrophobic Acrylic Foldable Single-Piece  
Posterior Chamber Intraocular Lens with the AutonoMe™ Automated Pre-loaded Delivery System**



**DESCRIPTION**

The Clareon™ Aspheric Hydrophobic Acrylic IOL (henceforth referred to as Clareon™ IOL, Model SY60WF) is provided in the AutonoMe™ Automated Pre-loaded Delivery System (henceforth referred to as AutonoMe™ Delivery System, Model CNA0T0) for a convenient, controlled means to reliably place the IOL into the capsular bag. The Clareon™ IOL is an ultraviolet and blue light filtering foldable single-piece posterior chamber intraocular lens. Each lens has an optical portion and mechanical support elements (haptics) composed of a high refractive index, soft hydrophobic acrylic material capable of being folded prior to insertion, which contains a covalently bonded blue light filtering chromophore. Alcon's proprietary chromophore filters blue light in a manner that approximates the human crystalline lens in the 400 to 475 nm wavelength range (Boettner and Wolter, 1962). The optic portion is biconvex and includes an aspheric surface. After surgical insertion into the eye, the lens gently unfolds to a full-size lens body. The haptics provide proper positioning of the lens optic within the capsular bag. The anterior aspheric surface of the Clareon™ IOL is designed with negative spherical aberration to compensate for the positive spherical aberration of an average cornea. The effects of this aspheric design feature have not been clinically assessed on the Clareon™ IOL.

The AutonoMe™ Delivery System is a single-use lens case and injector delivery system. This device arrives fully assembled with the IOL positioned within the lens bay. It features a speed-control-lever user interface that allows single-handed IOL delivery. IOL advancement is driven by an internal compressed gas cylinder, which provides speed modulation by varying speed-control-lever depression. The physical properties of this lens and delivery system are described in **Figures 1, 2, and 3** and **Table 1**.

**Table 1: Physical Characteristics of Clareon™ IOL**

<b>Physical Characteristics</b>	<b>Description</b>
Preloaded IOL Model	CNA0T0
Optic Type	Anterior Asymmetric Biconvex
Optics Material	Ultraviolet and blue light filtering Hydrophobic Acrylate/Methacrylate Copolymer
Spectral Transmission	10% transmittance at 403 nm (UV) for +20.0 diopter IOL
Index of Refraction	1.55 at 35°C
Optic Powers	+6.0 to +30.0 diopters (in 0.5 diopter increments)
Haptic Configuration	STABLEFORCE™ Modified-L Haptics
Haptic Material	Ultraviolet and blue light filtering Hydrophobic Acrylate/Methacrylate Copolymer
Optic Diameter/Ø <sub>B</sub> (mm)	6.0
Overall Length/Ø <sub>T</sub> (mm)	13.0
Haptic Angle	0°

NOTE: Text appearing in gray is for information purposes only.

**HOW SUPPLIED**

The Clareon™ Aspheric Hydrophobic Acrylic IOL is supplied dry and in the AutonoMe™ Delivery System, which is contained within a package terminally sterilized with ethylene oxide. The primary sterilization package must be opened only under aseptic conditions (see DIRECTIONS FOR USE).

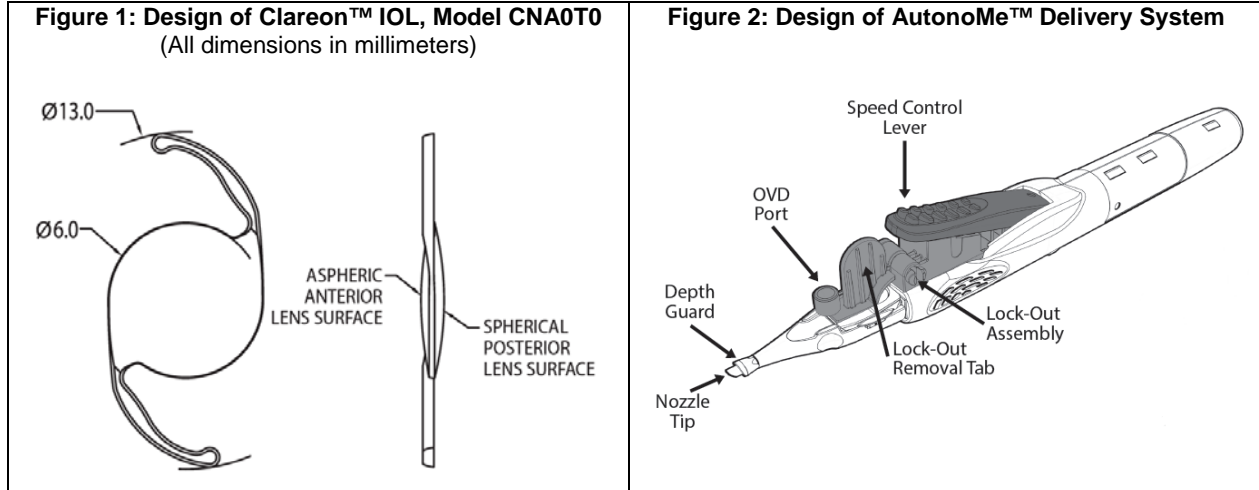

**Figure 3: Spectral Transmittance**

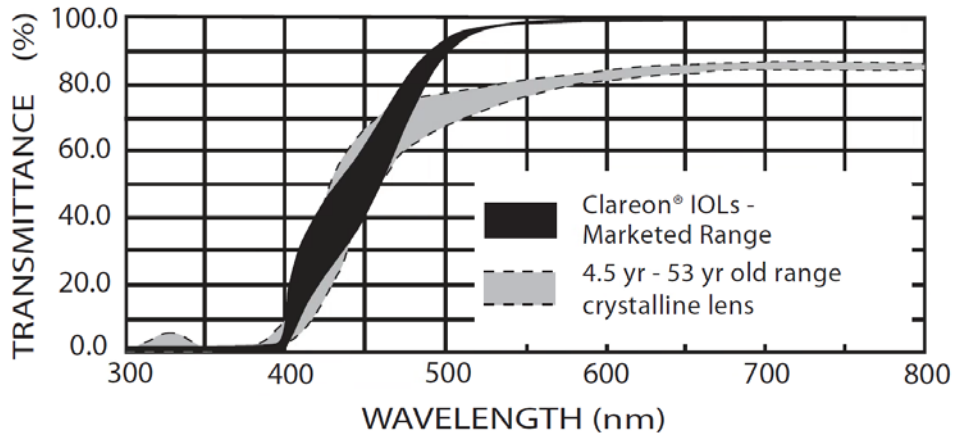

**NOTES:**

- The cutoff wavelength and the spectral transmittance curves presented here represent the range of transmittance values of IOLs made from hydrophobic acrylate/methacrylate copolymer with bonded UV-absorber and Alcon's proprietary blue light filtering chromophore.
- Measurements were by direct transmittance using Clareon™ IOLs with center thickness equivalent to the marketed range .
- Human lens data from Boettner and Wolter (1962).

**MODE OF ACTION (INTENDED USE)**

The Clareon™ IOL with the AutonoMe™ Delivery System provides a means to insert the IOL into the capsular bag in a controlled manner. The Clareon™ IOL is intended to be placed by a trained ophthalmic surgeon in the capsular bag in the posterior chamber of the eye, replacing the natural crystalline lens. This position allows the IOL to function as a refractive medium in the correction of aphakia. The aspheric biconvex optic compensates for the positive spherical aberration of the cornea as compared to a standard spherical optic.

**INDICATIONS**

The Clareon™ Aspheric Hydrophobic Acrylic Intraocular Lens (IOL) is indicated for primary implantation in the capsular bag in the posterior chamber of the eye for the visual correction of aphakia in adult patients in whom a cataractous lens has been removed.

**DEVICE PREPARATION AND IOL IMPLANTATION**

To accommodate the full diopter range of the Model CNA0T0 IOL, the AutonoMe™ Delivery System is supplied with an AutonoMe™ Nozzle or an AutonoMe™ C-size Nozzle depending on the IOL diopter. **Table 2** shows the combination of nozzle size and IOL diopter range.

**Table 2: Combinations of Nozzle Size and IOL Diopter Range**

Lens Model	Diopter Range	Nozzle Size
CNA0T0	6.0 - 25.0 D	AutonoMe™ Nozzle
	25.5 – 30.0 D	AutonoMe™ C-size Nozzle

During implantation of the Clareon™ IOL, an Alcon qualified OVD should be used. The use of an unqualified OVD may cause damage to the lens and potential complications during the implantation process. The qualified OVDs that can be used with this lens are listed in **Table 3**.

**Table 3: Qualified OVDs for Use with the Clareon™ IOL in the AutonoMe™ Delivery System, Model CNA0T0**

Lens Model	Qualified OVD
CNA0T0	VISCOAT™ OVD
	DISCOVISC™ OVD
	PROVISC™ OVD

**CALCULATION OF LENS POWER**

Accurate biometry is essential for successful visual outcomes. Preoperative calculation of required lens power for the Clareon™ IOL should be determined by the surgeon's experience and preference. A reference SRK/T A-Constant value for optical biometry equipment such as IOLMaster<sup>®</sup> or LenStar<sup>®</sup> as well as *contact* ultrasound biometry is listed on the outer label. The reference optical A-Constant anticipates the use of both corneal power and axial length values from optical biometry equipment with standard settings for a typical patient population and a spectacle far point at 6 meters. In general, A-constants must be "personalized" to compensate for such things as differences in instrumentation, surgical techniques, and IOL power calculation that may exist between clinical practices. IOL power calculation methods are often included with biometry equipment, and they are also described in the references (Hoffer 1993; Holladay 1997; Olsen 2007; Retzlaff, Sanders & Kraff 1990; Haigis 2014).

**WARNINGS**

1. The Clareon™ IOL is intended for implantation in the capsular bag only. There are no clinical data to demonstrate its safety and effectiveness for placement in the ciliary sulcus.
2. DO NOT re-sterilize the Clareon™ IOL or the AutonoMe™ Delivery System by any method.
3. DO NOT implant the IOL if the sterility has been compromised or if the sterile package has been unintentionally opened before use.
4. DO NOT reuse the Clareon™ IOL or AutonoMe™ Delivery System. The device is for single use only. Reuse of this single-use device may result in serious injury, such as but not limited to endophthalmitis.
5. Physicians considering lens implantation under any of the following circumstances should weigh the potential risk/benefit ratio: Patients in whom the posterior capsule is ruptured, zonules are damaged, or primary posterior capsulotomy is planned.

**PRECAUTIONS**

1. A high level of surgical skill is required for intraocular lens implantation. Surgeons should have completed proper ophthalmic training where they observed and/or assisted in numerous implantations and successfully completed one or more courses on intraocular lens implantation before attempting to implant intraocular lenses.
2. Prior to surgery, prospective patients should be informed of the possible risks and benefits associated with this IOL as well as the risks and benefits associated with cataract surgery. After surgery, physicians should provide an implant card to patients regarding the IOL implanted.
3. The safety and effectiveness of the Clareon™ IOL has not been substantiated in clinical trials in patients with certain pre-existing conditions and/or intraoperative conditions (listed in **Tables 4** and **5**) as these

NOTE: Text appearing in gray is for information purposes only.

patients were excluded from the clinical studies. Patients with pre-existing conditions may not achieve the visual acuity of patients without such conditions. As with the implantation of any IOL, careful preoperative evaluation and sound clinical judgment should be used by the surgeon to decide the benefit/risk ratio before implanting a lens in a patient with one or more of these conditions.

4. Do not store the Clareon™ IOL and the AutonoMe™ Delivery System at temperatures over 30 °C (86 °F).
5. Use the AutonoMe™ Delivery System at Operating Room temperatures between 18 °C (64 °F) and 23 °C (73 °F) after the device has been allowed to come to the operating room temperature over a 30 minute timeframe.
6. Once the lens is in position at the pause location on the nozzle, the lens should be implanted within 1 minute. Failure to adhere to manufacturer's recommendations may result in IOL damage.
7. Once the package is opened, handle the AutonoMe™ Delivery System with care. DO NOT use a system that has been accidentally dropped as internal or external device components may be damaged, and the damage may not be visible with inspection.
8. DO NOT use the device if it is activated prior to OVD addition as IOL damage may occur.
9. Contents are under pressure. DO NOT attempt to disassemble the device or alter it in any way.
10. As with any surgical procedure, there is risk involved. Potential complications accompanying cataract and/or IOL implantation surgery may include, but are not limited to, the following: lens epithelial cell on-growth, corneal endothelial cell damage, infection (endophthalmitis), toxic anterior segment syndrome (TASS), retinal detachment, vitritis, cystoid macular edema, corneal edema, pupillary block, cyclitic membrane, iris prolapse, hypopyon, anterior uveitis, hyphema, pigment dispersion, posterior capsule opacification, transient or persistent glaucoma, and secondary surgical interventions. Secondary surgical interventions include, but are not limited to: lens repositioning, lens replacement, vitreous aspiration or iridectomy for pupillary block, wound leak repair, and retinal detachment repair.

**Table 4: Preexisting Conditions with No Safety and Effectiveness Data**

<ul style="list-style-type: none"> <li>• Clinically severe corneal dystrophy (e.g., epithelial, stromal, or endothelial dystrophy), keratitis, keratoconjunctivitis, keratouveitis, keratopathy, or kerectasia</li> <li>• Previous corneal transplant</li> <li>• Aniridia</li> <li>• Iris neovascularization</li> <li>• Uncontrolled glaucoma</li> <li>• Rubella, congenital, traumatic, or complicated cataracts</li> <li>• Extremely shallow anterior chamber, not due to swollen cataract</li> <li>• Clinically significant macular degeneration</li> <li>• Previous retinal detachment</li> <li>• Diabetic retinopathy</li> </ul>	<ul style="list-style-type: none"> <li>• Optic nerve atrophy</li> <li>• Recurrent anterior or posterior segment inflammation of unknown etiology, or any disease producing an inflammatory reaction in the eye (e.g., iritis or uveitis)</li> <li>• Amblyopia</li> <li>• Pre-existing ocular conditions which may negatively impact stability of the implant (e.g., diagnosis of pseudoexfoliation syndrome)</li> <li>• Microphthalmos</li> <li>• Previous corneal or refractive surgery</li> <li>• Current or recent usage of alpha-1-selective adrenoceptor blocking agent or antagonist of alpha 1A adrenoceptor [e.g., Flomax<sup>†</sup> (tamsulosin HCL), Hytrin<sup>†</sup>, or Cardura<sup>†</sup>]</li> <li>• Pregnancy</li> </ul>
---	---

**Table 5: Intraoperative Conditions with No Safety and Effectiveness Data**

<ul style="list-style-type: none"> <li>• Other additional procedures during cataract surgery due to intraoperative complications that require further intervention (e.g., posterior rupture with vitreous loss)</li> <li>• Excessive iris mobility</li> <li>• Mechanical or surgical manipulation required to enlarge the pupil</li> </ul>	<ul style="list-style-type: none"> <li>• Vitreous loss (significant)</li> <li>• Anterior chamber bleeding (significant)</li> <li>• Complications in which the IOL stability could be compromised, including but not limited to zonular or capsular rupture or zonular weakness</li> <li>• Inability to place IOL in capsular bag due to surgical complications</li> </ul>
--	---

**DIRECTIONS FOR USE**

Step 1. Examine the label on the outer box for model, spherical equivalent power, proper configuration, and expiration date.

Step 2. After the outer box is open, inspect the device package for any damage.

**NOTE:** If damage is observed, use another Clareon™ IOL and AutonoMe™ Delivery System.

**US DFU**  
**Clareon™ Aspheric Hydrophobic Acrylic IOL with the AutonoMe™ Automated Pre-loaded Delivery System**  
**Model: CNA0T0**

NOTE: Text appearing in gray is for information purposes only.

---

- Step 3. Verify that the lens information on the device label (e.g., model, power, and serial number) is consistent with the information on the outer box labeling.
- Step 4. Remove the AutonoMe™ Delivery System by gripping the corner of the plastic tray and peeling open the TYVEK† material lid portion fully.
- Step 5. Transfer the device to a sterile environment.

**NOTE:** Ensure that the AutonoMe™ Delivery System has been allowed to come to the operating room temperature over a 30 minute timeframe prior to use.

- Step 6. Inspect the device nozzle for damage, particulates, or deformation. Ensure that the device is completely intact and that the plunger and lock-out assembly have not been moved.

**NOTE:** If the device does not pass the inspection criteria, use another Clareon™ IOL and AutonoMe™ Delivery System.

- Step 7. Fully insert the cannula containing OVD through the OVD port, and ensure that the cannula is perpendicular to the device as shown in Figure 4.

**NOTE:** Ensure that the Alcon qualified OVD has been allowed to come to the operating room temperature over a 20 minute timeframe prior to use. Only use an Alcon qualified OVD (see **Table 3**).

**!IMPORTANT: PERFORM Steps 8, 9, 10, AND 11 IN SEQUENCE, WITH MINIMAL DELAY BETWEEN STEPS.**

- Step 8. Fill the device until OVD can be observed flowing to the nozzle tip (**Figure 4**), then retract the cannula. This will require approximately 0.28 mL of OVD.

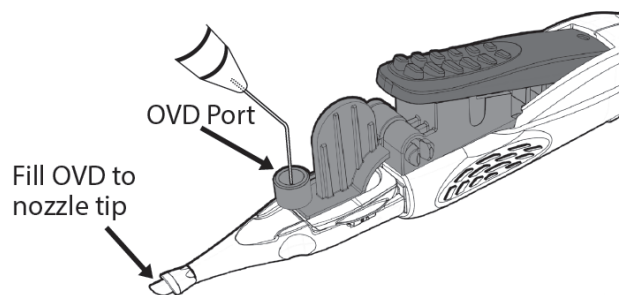
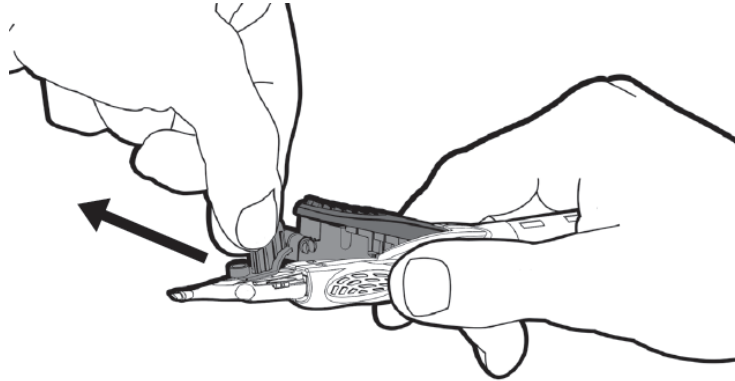

**Figure 4**

- Step 9. Remove the lock-out assembly by grasping the removal tab and directly pulling the entire lock-out assembly away from the device at an angle (**Figure 5**). Discard the lockout assembly.

**NOTE:** Do not attempt to add OVD to the device after the lock-out assembly has been removed, or lens damage may result. Take care not to depress the Speed Control Lever until ready to advance the IOL (Step 10).

NOTE: Text appearing in gray is for information purposes only.



**Figure 5**

Step 10. Fully depress the Speed Control Lever to move the plunger forward and fold the IOL (**Figure 6a**). To stop the IOL, release the Speed Control Lever when the front edge of the optic is even with the pause location on the nozzle (**Figure 6b**).

**NOTE:** The AutonoMe™ Delivery System is a pneumatic device. Thus, a click may be heard as the Speed Control Lever is initially depressed, and the device is activated.

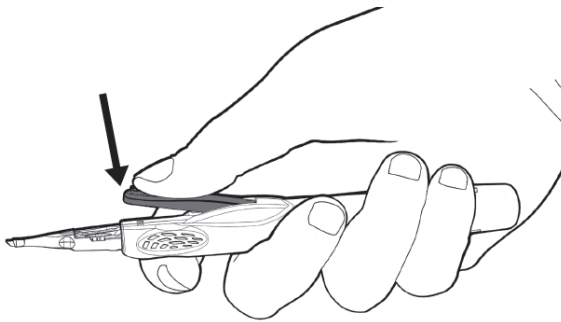

**Figure 6a**

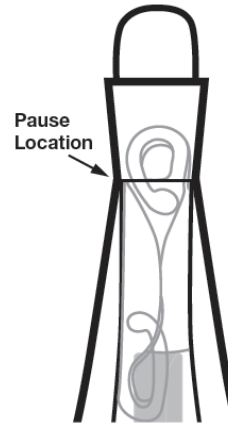

**Figure 6b**

Step 11. Visually inspect the lens to determine the position of the leading and trailing haptics (Refer to **Figure 7**). Verify that the plunger is in contact with the trailing optic edge.

**NOTE:** Once the lens is in position at the pause location on the nozzle, **the lens should be implanted within 1 minute.**

**!!IMPORTANT: DO NOT IMPLANT LENS IF THE HAPTIC EXITS NOZZLE PRIOR TO INSERTION THROUGH INCISION.**

US DFU

Clareon™ Aspheric Hydrophobic Acrylic IOL with the AutonoMe™ Automated Pre-loaded Delivery System  
Model: CNA0T0

NOTE: Text appearing in gray is for information purposes only.

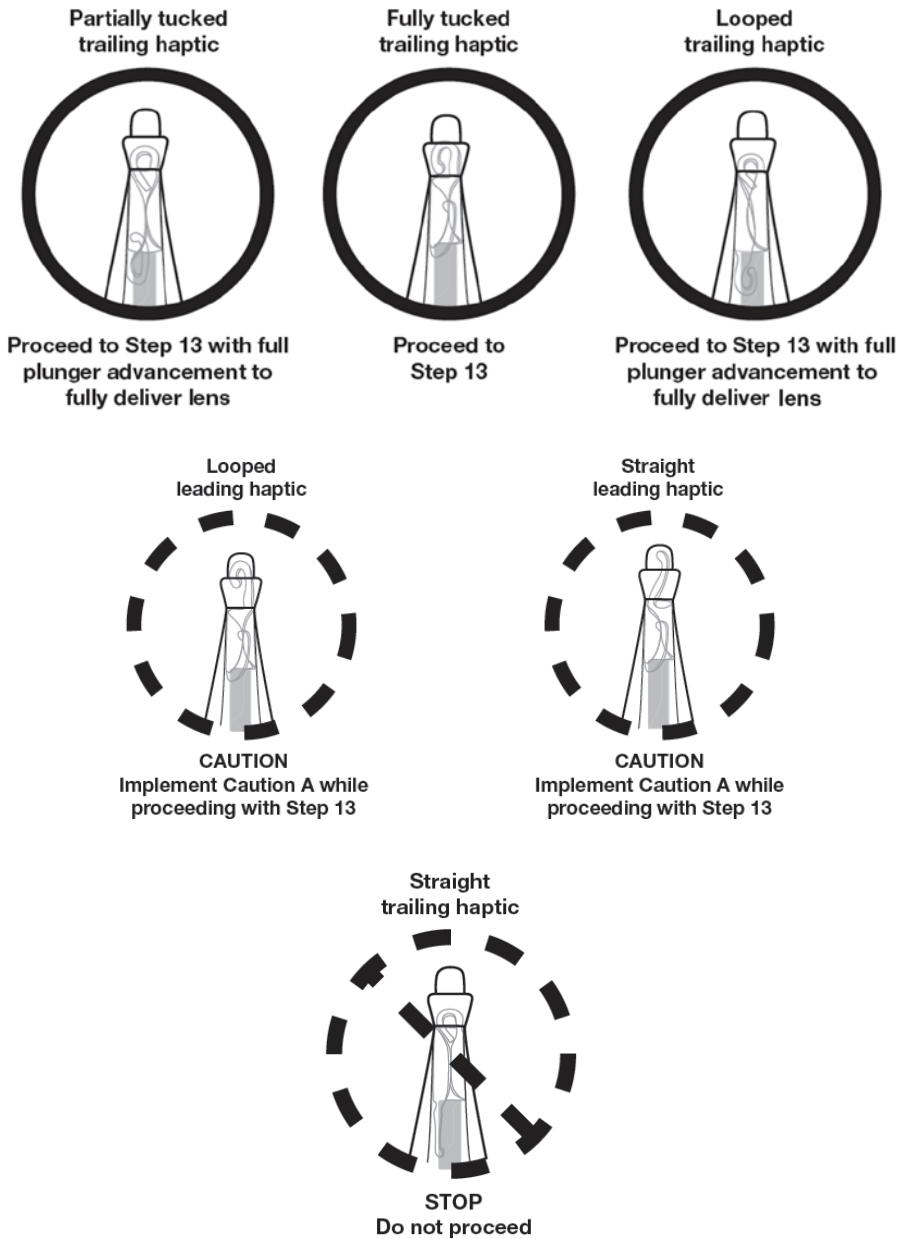

**Figure 7**

**NOTE:** In the three acceptable trailing haptic configurations shown above (denoted by the solid circles), different leading haptic configurations are also shown; all configurations shown are acceptable to proceed.

**CAUTION A:** If the leading haptic is straight or looped and extended in front of the lens, rotate device clockwise to bevel left before advancing plunger to ensure the leading haptic is correctly placed in the capsular bag. In order to ensure that the lens unfolds anterior side up within the capsular bag, rotate the device back to center or slightly bevel right as the optic exits the nozzle.

Step 12. Refer to **Table 2**. The 25.5 D to 30.0 D IOLs are provided with the C-size nozzle (denoted by a “C” on the top of the nozzle, as shown in **Figure 8b**). Confirm an appropriate incision for the corresponding nozzle size prior to lens implantation.

## US DFU

### Clareon™ Aspheric Hydrophobic Acrylic IOL with the AutonoMe™ Automated Pre-loaded Delivery System Model: CNA0T0

NOTE: Text appearing in gray is for information purposes only.

Step 13. Insert the nozzle tip into the incision as far as needed to facilitate lens implantation, using the depth guard (Figures 8a and 8b) as the insertion limit, and aim the nozzle tip at the anterior capsule opening.

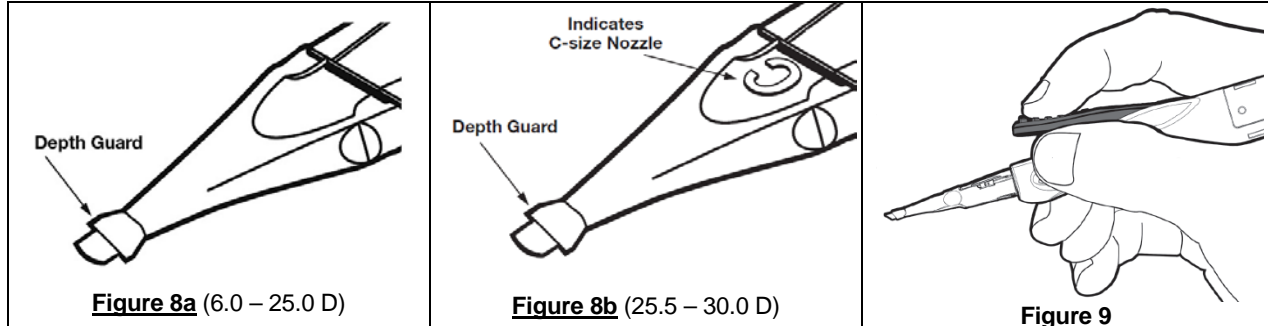

Step 14. Advance the plunger by depressing the Speed Control Lever (Refer to Figure 9). Maintain adequate pressure to ensure the nozzle tip remains in the incision. Plunger speed can be varied by the amount that the Speed Control Lever is depressed. The plunger can be stopped at any time by releasing the Speed Control Lever.

Step 15. Use a suitable positioning instrument to position the lens within the capsular bag and in a planar fashion parallel to the iris.

Step 16. Safely discard the entire device as medical waste in accordance with local laws and regulations.

#### MAGNETIC RESONANCE COMPATIBILITY

The Clareon™ IOL is magnetic resonance (MR) Safe. The IOL consists of acrylate/methacrylate copolymer material, which is a non-conducting, non-metallic, non-magnetic material that poses no known hazards in all magnetic resonance imaging environments.

#### PATIENT REGISTRATION

The Patient Identification Card included in the package is to be completed and given to the patient, together with instructions to keep the card as a permanent record to be shown to any eye care practitioner that the patient consults in the future.

Each patient must be registered with Alcon Laboratories, Inc., immediately following implantation of one of these lenses. Registration is accomplished by completing the Implant Registration Card that is enclosed in the lens box and mailing it to Alcon Laboratories, Inc. Patient registration is essential for the long-term patient follow-up program and will assist Alcon Laboratories, Inc. in responding to reports of adverse events.

#### SERIOUS INCIDENT REPORTING

Any serious incident that may reasonably be regarded as device related should be reported to Alcon Laboratories, Inc.:

By Phone:  
In USA - (800) 757-9780  
Website:

<http://www.alcon.com/contact-us/>

Each IOL is identified by a serial number which provides traceability, and this information should be given to Alcon.

#### EXPIRATION DATE

Sterility is guaranteed until the use-by date unless the primary sterilization package is damaged or opened. The use-by date is clearly indicated on the outer box label of the AutonoMe™ Delivery System. Any lens held after the use-by date should be returned to Alcon Laboratories, Inc. (see RETURNED GOODS POLICY).

#### RETURNED GOODS POLICY

Returned lenses will only be accepted in exchange for other products, not credit. All returns must be accompanied by an Alcon Laboratories, Inc. Returned Goods Number and should be shipped via traceable means. A Returned Goods Number is obtained by contacting Alcon Laboratories, Inc. Customer Service Department. Issuance of this



**US DFU**

**Clareon™ Aspheric Hydrophobic Acrylic IOL with the AutoMe™ Automated Pre-loaded Delivery System  
Model: CNA0T0**

NOTE: Text appearing in gray is for information purposes only.

---

number does not constitute final acceptance of the returned products. For detailed policy guidelines including exchange, please contact your Sales or Customer Service Representative.

**CLINICAL STUDY OVERVIEW FOR Clareon™ ASPHERIC HYDROPHOBIC ACRYLIC IOL**

A prospective, multicenter, open-label clinical study in adult subjects requiring cataract surgery with IOL implantation was performed on the Clareon™ IOL in the United States. The objective of this study was to demonstrate favorable visual acuity and adverse event outcomes for the Clareon™ IOL compared to historical safety and performance endpoint (SPE) rates as reported in EN ISO 11979-7:2014. The results achieved by the subjects successfully followed for 12 Months postoperatively (defined as 330 to 420 days postoperative) provide reasonable assurance that the Clareon™ IOL is a safe and effective device for the visual correction of aphakia following cataract surgery.

A summary of the clinical study data is provided below to describe the performance characteristics of the IOL. Please use caution when comparing these results with results from similar device studies due to potential differences in patient cohorts, test methods, etc.

NOTE: Text appearing in gray is for information purposes only.

**STUDY RESULTS FOR Clareon™ ASPHERIC HYDROPHOBIC ACRYLIC IOL**

The subject population in the clinical study consisted of 350 subjects in need of cataract surgery that were unilaterally implanted, the percentage of females (60.9%) exceeded the percentage of males (39.1%) enrolled. The mean age for the total population was 69.7 years.

Visual Acuity

The best corrected distance visual acuity (BCDVA) achieved at one year postoperatively by the Best Case Analysis Set is presented in **Table 6** and visual acuity achieved by All-Implanted Analysis Set is presented in **Table 7**. Similar data for BCDVA expressed as Snellen values are presented in **Tables 8** and **9**. The Best Case analysis included all eyes successfully implanted with the test article, had at least one postoperative visit, did not have any ocular pathology at Visit 0 (preoperative), had no macular degeneration at any visit, and did not have any previous surgery for the correction of refractive errors. All-Implanted Analysis set includes all eyes with successful test article implantation.

The one-sided exact 95% upper confidence limit for the percentage of subjects with monocular BCDVA of 0.3 logMAR or better at 12 months postoperative (Visit 5) is greater than or equal to the SPE rates as reported in EN ISO 11979-7:2014.

The uncorrected distance visual acuity (UCDVA) at one year postoperatively is presented in **Table 10** for the Best Case Analysis, and UCDVA achieved by All-Implanted Analysis Set is presented in **Table 11**.

**Table 6: Best Corrected Visual Acuity in the Best Case Analysis Set at Month 12, Clareon™ IOL**

Visual Acuity	n	%
0.0 logMAR or better	271	83.1
0.1 logMAR or better	307	94.2
0.2 logMAR or better	323	99.1
0.3 logMAR or better	325	99.7
Worse than 0.3 logMAR	1	0.3
ISO SPE Rate for % of 0.3 logMAR or better	96.7%	
N	326	
ISO SPE Rate = BS EN ISO 11979-7:2014, Ophthalmic Implants - Intraocular Lenses - Part 7: Clinical Investigations, Table B.4 - Posterior Chamber IOL Adverse Event Safety and Performance Endpoint Rates		

**Table 7: Best Corrected Visual Acuity in the All-Implanted Analysis Set at Month 12, Clareon™ IOL**

Visual Acuity	n	%
0.0 logMAR or better	277	81.0
0.1 logMAR or better	318	93.0
0.2 logMAR or better	339	99.1
0.3 logMAR or better	341	99.7
Worse than 0.3 logMAR	1	0.3
ISO SPE Rate for % of 0.3 logMAR or better	92.5%	
N	342	
ISO SPE Rate = BS EN ISO 11979-7:2014, Ophthalmic Implants - Intraocular Lenses - Part 7: Clinical Investigations, Table B.3 - Posterior Chamber IOL Adverse Event Safety and Performance Endpoint Rates		

**Table 8: Best Corrected Visual Acuity in the Best Case Analysis Set at Month 12 (Snellen), Clareon™ IOL**

Visual Acuity	n	%
20/20 or better	287	88.0
20/25 or better	316	96.9
20/32 or better	324	99.4
20/40 or better	325	99.7
Worse than 20/40	1	0.3

**US DFU**

**Clareon™ Aspheric Hydrophobic Acrylic IOL with the AutoMe™ Automated Pre-loaded Delivery System  
Model: CNA0T0**

NOTE: Text appearing in gray is for information purposes only.

N	326		
Note: 20/20 = 0.04 logMAR	20/25 = 0.14 logMAR	20/32 = 0.24 logMAR	
20/40 = 0.34 logMAR			

**Table 9: Best Corrected Visual Acuity in the All-Implanted Analysis Set at Month 12 (Snellen), Clareon™ IOL**

Visual Acuity	n	%
20/20 or better	297	86.8
20/25 or better	331	96.8
20/32 or better	340	99.4
20/40 or better	341	99.7
Worse than 20/40	1	0.3
N	342	
Note: 20/20 = 0.04 logMAR	20/25 = 0.14 logMAR	20/32 = 0.24 logMAR
20/40 = 0.34 logMAR		

**Table 10: Uncorrected Visual Acuity in the Best Case Analysis Set at Month 12, Clareon™ IOL**

Statistic	(N = 334)
n	326
Mean (SD)	0.042 (0.1348)
Median	-0.02
(Min, Max)	(-0.20, 0.70)
95% CI	(-0.027, -0.056)

**Table 11: Uncorrected Visual Acuity in the All-Implanted Analysis Set at Month 12, Clareon™ IOL**

Statistic	(N = 350)
n	342
Mean (SD)	0.043 (0.1339)
Median	0.02
(Min, Max)	(-0.20, 0.70)
95% CI	(0.029, 0.057)

**US DFU**

**Clareon™ Aspheric Hydrophobic Acrylic IOL with the AutonoMe™ Automated Pre-loaded Delivery System  
Model: CNA0T0**

NOTE: Text appearing in gray is for information purposes only.

Adverse Events

The cumulative and persistent adverse events rates for the Safety Analysis Set are presented in **Table 12**. Cumulative adverse events are those that occur at any point in the study while persistent adverse events are those that occur or are ongoing at the 12 Month Visit. The Safety Analysis Set included all eyes with attempted implantation with the test article (successful or aborted after contact with the eye). In this study, the number of eyes in the Safety Analysis Set was equivalent to the All-Implanted Analysis Set.

For both cumulative and persistent adverse events, the exact one-sided 95% lower confidence limit of cumulative and persistent adverse events were within limits compared to the SPE rates reported in EN ISO 11979-7:2014.

**Table 12: Cumulative and Persistent Adverse Events in the Safety Analysis Set, Clareon™ IOL**

	(N = 350)			
	n (%)	2-sided 95% CI	1-sided 95% Lower CL	SPE %
<b>Cumulative Serious Adverse Events</b>				
Cystoid macular oedema	3 (0.9)	(0.18, 2.48)	0.23	3.0
Hypopyon	0 (0.0)	(0.00, 1.05)	0.00	0.3
Endophthalmitis	0 (0.0)	(0.00, 1.05)	0.00	0.1
Lens dislocated from posterior chamber	0 (0.0)	(0.00, 1.05)	0.00	0.1
Pupillary block	0 (0.0)	(0.00, 1.05)	0.00	0.1
Retinal detachment	0 (0.0)	(0.00, 1.05)	0.00	0.3
Secondary surgical intervention*	6 (1.7)	(0.63, 3.69)	0.75	0.8
<b>Other</b>				
Herpes virus infection	1 (0.3)	(0.01, 1.58)	0.01	NA
Macular fibrosis	1 (0.3)	(0.01, 1.58)	0.01	NA
Macular hole	1 (0.3)	(0.01, 1.58)	0.01	NA
Punctate keratitis	1 (0.3)	(0.01, 1.58)	0.01	NA
Retinal tear	2 (0.6)	(0.07, 2.05)	0.10	NA
<b>Persistent Serious Adverse Events</b>				
Corneal stroma oedema	0 (0.0)	(0.00, 1.05)	0.00	0.3
Cystoid macular oedema	1 (0.3)	(0.01, 1.58)	0.01	0.5
Iritis	0 (0.0)	(0.00, 1.05)	0.00	0.3
Raised IOP requiring treatment	0 (0.0)	(0.00, 1.05)	0.00	0.4
CI = Confidence Interval CL = Confidence Limit SPE = Safety and Performance Endpoint Persistent = Present or ongoing at the final scheduled visit IOP = Intraocular Pressure SPE rates are from BS EN ISO 11979-7:2014, Ophthalmic Implants - Intraocular Lenses - Part 7: Clinical Investigations, Table B.2 - Posterior Chamber IOL Adverse Event Safety and Performance Endpoint Rates If an eye has multiple occurrences of an AE, the eye is presented only once in the respective eye count column (n) for the corresponding AE. "Other" includes the MedDRA Preferred Term for ocular SAEs that do not belong to any predefined SPE categories. Percentages are calculated as (n/N) * 100. The SPE rate is considered not exceeded if the 1-sided 95% lower CL for an AE is less than the SPE%. *None of these secondary surgical interventions were related to the IOL.				

**US DFU**

**Clareon™ Aspheric Hydrophobic Acrylic IOL with the AutonoMe™ Automated Pre-loaded Delivery System  
Model: CNA0T0**

NOTE: Text appearing in gray is for information purposes only.

















**IOL Observations**

At all five scheduled postoperative visits and at unscheduled visits, slit-lamp examinations were performed. The list of pre-specified slit-lamp findings included IOL observations, which were described as IOL glistenings, scratches/cracks on the IOL, and surface haze on the IOL. Across 1,852 postoperative (including unscheduled) visits, no IOL observations (IOL glistenings, scratches/cracks on the IOL, and surface haze on the IOL) were noted for the Clareon™ IOL.

**REFERENCES**

Boettner, E.A. and Wolter, J.R. Transmission of the ocular media. *Invest. Ophthalmol.* 1962;1:776-83.  
 Haigis W. ULIB - User group for Laser Interference Biometry. Updated 2014 Jul 17; cited 2015 Mar 13. Available at: <http://ocusoft.de/ulib/>.  
 Hoffer KJ. The Hoffer Q formula: a comparison of theoretic and regression formulas. *J Cataract Refract Surg.* 1993;19(6):700-12.  
 Holladay JT. Standardizing constants for ultrasonic biometry, keratometry, and intraocular lens power calculations. *J Cataract Refract Surg.* 1997;23(9):1356-70.  
 Olsen T. Calculation of intraocular lens power: a review. *Acta Ophthalmol Scand.* 2007;85(5):472-85.  
 Retzlaff JA, Sanders DR, Kraff M. *Lens Implant Power Calculation.* 3rd ed. Thorofare (NJ): Slack, Inc.; 1990.

**STAND ALONE SYMBOLS FROM ISO 7000/ISO 7001\* USED ON LABELING  
(ISO 7000 Title: Graphical Symbols for Use on Equipment)  
(\*ISO 7001 Title: Graphical symbols – Public information symbols)**

Symbol	Reference Number from ISO 7000 / ISO 7001*	Symbol Title / Explanatory Text
	1051	Do not re-use
	2608	Do not re-sterilize
	2607	Use-by date
	2501	Sterilized using ethylene oxide
	2493	Catalogue number
	2498	Serial number
	0434A	Caution
	3082	Manufacturer
	0632	Temperature limit
	1641	Consult instructions for use
	3500	Electronic instructions for use
	2606	Do not use if package has been damaged
	2497	Date of manufacture
	3079	Open here
	3010	RFID tag, general
	5662	Date
	PI PF 002*	Hospital











\*This symbol is the only one from ISO 7001 in the table above.

**US DFU**

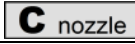
**Clareon™ Aspheric Hydrophobic Acrylic IOL with the AutoMe™ Automated Pre-loaded Delivery System  
Model: CNA0T0**

NOTE: Text appearing in gray is for information purposes only.

**ABBREVIATIONS or OTHER SYMBOLS USED ON LABELING**

Abbreviation or Symbol	Explanatory Text
	Medical device
	Single sterile barrier system
IOL	Intraocular lens
OVD	Ophthalmic viscosurgical device
	UV and Blue Light Filter
	Posterior chamber IOL
UV	Ultraviolet
D	Diopter
Ø <sub>B</sub>	Body diameter (Optic diameter)
Ø <sub>T</sub>	Overall diameter (Overall length)
L	Left
R	Right
PWR	Spherical Equivalent Power
	D-size nozzle
	C-size nozzle
	Not made with natural rubber latex
	Does not contain PHT (phthalates)
	MR (magnetic resonance) Safe
	Caution: Federal (USA) Law restricts this device to sale by or on the order of a physician
	Authorized Representative in the European Community



Alcon Laboratories, Inc  
6201 South Freeway  
Fort Worth, TX 76134-2099 USA

† Trademarks are the property of their respective owners.

<insert copyright>

**ALCON** (current approved logo)

**Product: Clareon™ Aspheric Hydrophobic Acrylic IOL**  
**Model: SY60WF**

Note: Text in gray is for informational purposes only

**Directions for Use**

<Note: Include revision date on approved DFU using YYYY-MM format>



<https://ifu.alcon.com>

XX-XXX-XXX-XXX (Insert Commodity Number)

**PRODUCT INFORMATION**

Alcon Laboratories, Inc.

Clareon™ Aspheric Hydrophobic Acrylic IOL (logo)

**STERILE UV and Blue Light Filtering Acrylic Foldable  
Aspheric Posterior Chamber Intraocular Lenses**



**DESCRIPTION**

The Clareon™ Aspheric Hydrophobic Acrylic IOL (henceforth referred to as Clareon™ IOL) is an ultraviolet and blue light filtering foldable single-piece posterior chamber intraocular lens. Each lens has an optical portion and mechanical support elements (haptics) composed of a high refractive index soft hydrophobic acrylic material capable of being folded prior to insertion, which contains a covalently bonded blue light filtering chromophore. Alcon's proprietary chromophore filters blue light in a manner that approximates the human crystalline lens in the 400 to 475 nm wavelength range (Boettner and Wolter, 1962). The optic portion is biconvex and includes an aspheric surface. After surgical insertion into the eye, the lens gently unfolds to a full-size lens body. The haptics provide proper positioning of the lens optic within the capsular bag.

The anterior aspheric surface of the Clareon™ IOL is designed with negative spherical aberration to compensate for the positive spherical aberration of an average cornea. The effects of this aspheric design feature have not been clinically assessed on the Clareon™ IOL. The physical properties of this lens are described in **Figures 1 and 2** and **Table 1**.

**Table 1: Physical Characteristics of Clareon™ IOL**

<b>Physical Characteristics</b>	<b>Description</b>
IOL Model	SY60WF
Optic Type	Anterior Asymmetric Biconvex
Optics Material	Ultraviolet and Blue Light Filtering Hydrophobic Acrylate/Methacrylate Copolymer
Spectral Transmission	10% transmittance at 403 nm (UV) for +20.0 diopter IOL
Index of Refraction	1.55 at 35°C
Optic Powers	+6.0 to +30.0 diopters (in 0.5 diopter increments)
Haptic Configuration	STABLEFORCE™ Modified-L Haptics
Haptic Material	Ultraviolet and Blue Light Filtering Hydrophobic Acrylate/Methacrylate Copolymer
Optic Diameter/ $\varnothing_B$ (mm)	6.0
Overall Length/ $\varnothing_T$ (mm)	13.0
Haptic Angle	0°

**HOW SUPPLIED**

The Clareon™ Aspheric Hydrophobic Acrylic IOL is supplied dry, in a package terminally sterilized with ethylene oxide, and must be opened only under aseptic conditions (see DIRECTIONS FOR USE).

**Product: Clareon™ Aspheric Hydrophobic Acrylic IOL**  
**Model: SY60WF**

Note: Text in gray is for informational purposes only

**Figure 1: Design of Clareon™ IOL**  
**Model SY60WF**  
(All dimensions in millimeters)

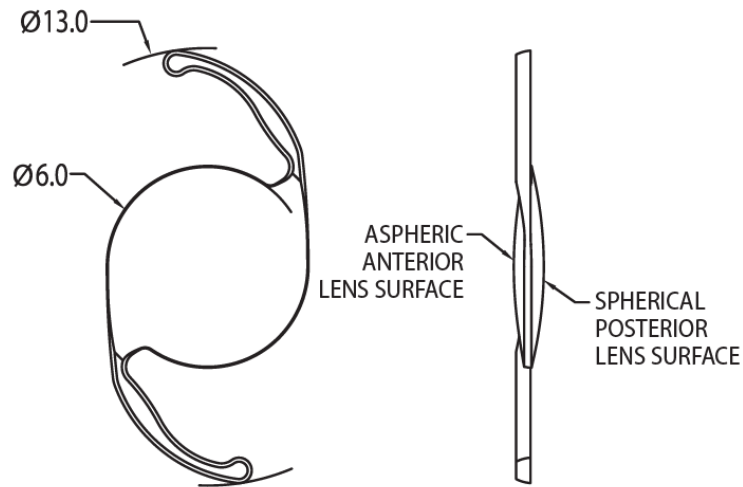

**Figure 2: Spectral Transmittance**

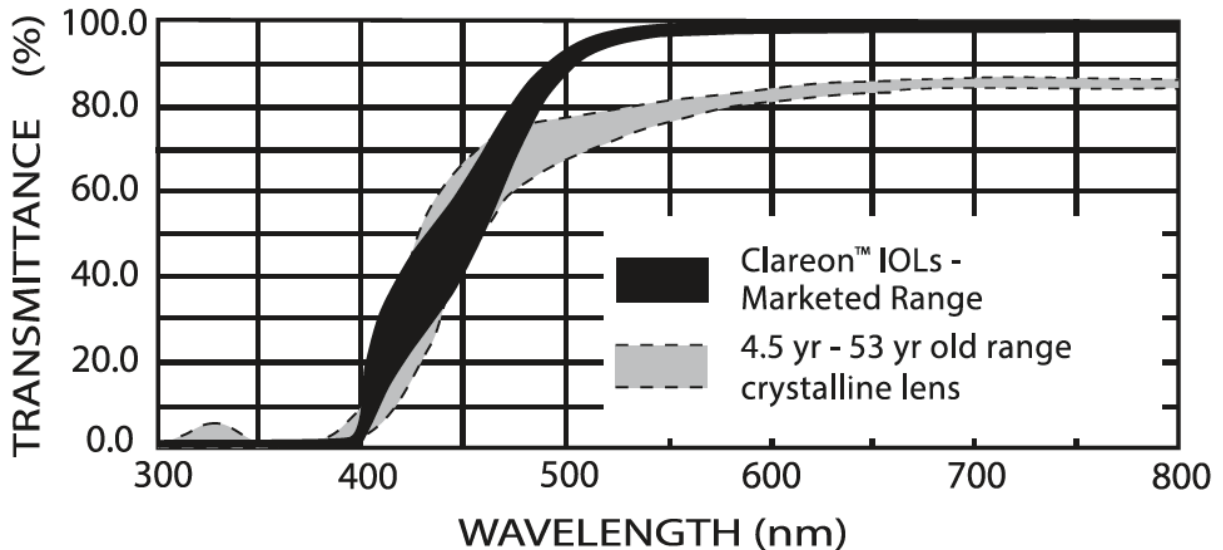

**NOTES:**

- The cutoff wavelength and the spectral transmittance curves presented here represent the range of transmittance values of IOLs made from hydrophobic acrylate/methacrylate copolymer with bonded UV-absorber and Alcon's proprietary blue light filtering chromophore.
- Measurements were by direct transmittance using Clareon™ IOLs with center thickness equivalent to the marketed range.
- Human lens data from Boettner and Wolter (1962).

**MODE OF ACTION (INTENDED USE)**

The Clareon™ Aspheric Hydrophobic Acrylic IOL is intended for use by a trained ophthalmic surgeon. The IOL is intended to be placed in the capsular bag in the posterior chamber of the eye, replacing the natural crystalline lens. This position allows the IOL to function as a refractive medium in the correction of aphakia. The aspheric biconvex optic compensates for the positive spherical aberration of the cornea as compared to a standard spherical optic.



**Product: Clareon™ Aspheric Hydrophobic Acrylic IOL**  
**Model: SY60WF**

Note: Text in gray is for informational purposes only

**INDICATIONS**

The Clareon™ Aspheric Hydrophobic Acrylic Intraocular Lens (IOL) is indicated for primary implantation in the capsular bag in the posterior chamber of the eye for the visual correction of aphakia in adult patients in whom a cataractous lens has been removed.

**QUALIFIED COMBINATIONS FOR IOL IMPLANTATION**

During implantation of the Clareon™ IOL, an Alcon qualified delivery system and an ophthalmic viscosurgical device (OVD) combination should be used. The use of an unqualified combination may cause damage to the lens and potential complications during the implantation process. Alcon recommends using the qualified MONARCH™ IOL Delivery System (Cartridge and Handpiece) or any other Alcon qualified combination. The qualified combinations that can be used with this lens are listed by row in **Table 2**.

**Table 2: Qualified Combinations of Compatible Products**

<b>Lens Model</b>	<b>Diopter Range</b>	<b>Cartridge</b>	<b>Handpiece</b>	<b>Ophthalmic Viscosurgical Device (OVD)</b>
SY60WF	+6.0 to +25.0	MONARCH™ III D (8065977763)	MONARCH™ III (blue) (8065977773)	VISCOAT™ OVD PROVISC™ OVD
	+6.0 to +30.0	MONARCH™ III C (8065977762)	MONARCH™ II (green) (8065977771) or MONARCH™ III (blue) (8065977773)	

Contact Alcon for any additional Alcon qualified OVDs, handpieces, and cartridges for use with this lens.

**CALCULATION OF LENS POWER**

Accurate biometry is essential for successful visual outcomes. Preoperative calculation of required lens power for the Clareon™ IOL should be determined by the surgeon's experience and preference. A reference SRK/T A-Constant value for optical biometry equipment such as IOLMaster<sup>®</sup> or LenStar<sup>®</sup> as well as *contact* ultrasound biometry is listed on the outer label. The reference optical A-Constant anticipates the use of both corneal power and axial length values from optical biometry equipment with standard settings for a typical patient population and a spectacle far point at 6 meters. In general, A-constants must be "personalized" to compensate for such things as differences in instrumentation, surgical techniques, and IOL power calculation that may exist between clinical practices. IOL power calculation methods are often included with biometry equipment, and they are also described in the references (Hoffer 1993; Holladay 1997; Olsen 2007; Retzlaff, Sanders & Kraff 1990; Haigis 2014).

**WARNINGS**

1. The Clareon™ IOL is intended for implantation in the capsular bag only. There are no clinical data to demonstrate its safety and effectiveness for placement in the ciliary sulcus.
2. DO NOT re-sterilize these intraocular lenses by any method.
3. DO NOT implant the IOL if the sterility has been compromised or if the sterile package has been unintentionally opened before use.
4. DO NOT reuse the IOL. This device is for single patient use only. Reuse of this single-use device may result in serious injury, such as but not limited to endophthalmitis.
5. Physicians considering lens implantation under any of the following circumstances should weigh the potential risk/benefit ratio: Patients in whom the posterior capsule is ruptured, zonules are damaged, or primary posterior capsulotomy is planned.

**PRECAUTIONS**

1. A high level of surgical skill is required for intraocular lens implantation. The surgeon should have observed and/or assisted in numerous implantations and successfully completed one or more courses on intraocular lens implantation before attempting to implant intraocular lenses.
2. Prior to surgery, prospective patients should be informed of the possible risks and benefits associated with this IOL as well as the risks and benefits associated with cataract surgery. After surgery, physicians should provide an implant card to patients regarding the IOL implanted.
3. The safety and effectiveness of the Clareon™ IOL has not been substantiated in clinical trials in patients with certain pre-existing conditions and/or intraoperative conditions (listed in **Tables 3** and **4**) as these patients were excluded from the clinical studies. Patients with pre-existing conditions may not achieve the

**Product: Clareon™ Aspheric Hydrophobic Acrylic IOL  
Model: SY60WF**

Note: Text in gray is for informational purposes only

visual acuity of patients without such conditions. As with the implantation of any IOL, careful preoperative evaluation and sound clinical judgment should be used by the surgeon to decide the benefit/risk ratio before implanting a lens in a patient with one or more of these conditions.

4. Follow the section regarding directions for use (see below) for information on the maximum allowed time for the IOL to stay in the folded condition. Failure to adhere to manufacturer's recommendations may result in IOL damage.
5. DO NOT store the intraocular lenses over 30 °C (86 °F).
6. As with any surgical procedure, there is risk involved. Potential complications accompanying cataract and/or IOL implantation surgery may include, but are not limited to, the following: lens epithelial cell on-growth, corneal cell endothelial damage, infection (endophthalmitis), toxic anterior segment syndrome (TASS), retinal detachment, vitritis, cystoid macular edema, corneal edema, pupillary block, cyclitic membrane, iris prolapse, hypopyon, anterior uveitis, hyphema, pigment dispersion, posterior capsule opacification, transient or persistent glaucoma, and secondary surgical interventions. Secondary surgical interventions include, but are not limited to: lens repositioning, lens replacement, vitreous aspiration or iridectomy for pupillary block, wound leak repair, and retinal detachment repair.

**Table 3: Preexisting Conditions with No Safety and Effectiveness Data**

<ul style="list-style-type: none"> <li>• Clinically severe corneal dystrophy (e.g., epithelial, stromal, or endothelial dystrophy), keratitis, keratoconjunctivitis, keratouveitis, keratopathy, or kerectasia</li> <li>• Previous corneal transplant</li> <li>• Aniridia</li> <li>• Iris neovascularization</li> <li>• Uncontrolled glaucoma</li> <li>• Rubella, congenital, traumatic, or complicated cataracts</li> <li>• Extremely shallow anterior chamber, not due to swollen cataract</li> <li>• Clinically significant macular degeneration</li> <li>• Previous retinal detachment</li> <li>• Diabetic retinopathy</li> </ul>	<ul style="list-style-type: none"> <li>• Optic nerve atrophy</li> <li>• Recurrent anterior or posterior segment inflammation of unknown etiology, or any disease producing an inflammatory reaction in the eye (e.g., iritis or uveitis)</li> <li>• Amblyopia</li> <li>• Pre-existing ocular conditions which may negatively impact stability of the implant (e.g., diagnosis of pseudoexfoliation syndrome)</li> <li>• Microphthalmos</li> <li>• Previous corneal or refractive surgery</li> <li>• Current or recent usage of alpha-1-selective adrenoceptor blocking agent or antagonist of alpha 1A adrenoceptor [e.g., Flomax<sup>†</sup> (tamsulosin HCL), Hytrin<sup>†</sup>, or Cardura<sup>†</sup>]</li> <li>• Pregnancy</li> </ul>
---	---

**Table 4: Intraoperative Conditions with No Safety and Effectiveness Data**

<ul style="list-style-type: none"> <li>• Other additional procedures during cataract surgery due to intraoperative complications that require further intervention (e.g., posterior rupture with vitreous loss)</li> <li>• Excessive iris mobility</li> <li>• Mechanical or surgical manipulation required to enlarge the pupil</li> </ul>	<ul style="list-style-type: none"> <li>• Vitreous loss (significant)</li> <li>• Anterior chamber bleeding (significant)</li> <li>• Complications in which the IOL stability could be compromised, including but not limited to zonular or capsular rupture or zonular weakness</li> <li>• Inability to place IOL in capsular bag due to surgical complications</li> </ul>
--	---

**DIRECTIONS FOR USE**

1. Examine the label on the outer box for model, spherical equivalent power, proper configuration, and expiration date.
2. After the outer box is open, verify lens primary label information (e.g., model, power, and serial number) is consistent with information on outer box labeling.
3. Inspect the primary package carefully for tears, cuts, punctures, or other signs that the pouch has been opened or damaged. This device is sterile until the primary package is opened. DO NOT implant the IOL if the sterility has been compromised or if the sterile package has been unintentionally opened before use (see RETURNED GOODS POLICY).
4. Open the undamaged primary package and transfer the case to a sterile environment. Carefully open the case to expose the lens.
5. Use instrumentation that is scrupulously clean to minimize the occurrence of marks. Any forceps used for lens handling must have round edges and smooth surfaces.

**Product: Clareon™ Aspheric Hydrophobic Acrylic IOL**  
**Model: SY60WF**

Note: Text in gray is for informational purposes only

---

6. Handle the IOL by the haptics only when removing the lens from the case. DO NOT grasp the optical area with forceps. Handle lenses carefully to avoid damage to lens surfaces or haptics. DO NOT attempt to reshape haptics in any way.
7. Examine the IOL carefully prior to insertion to ensure that particles have not adhered during handling.
8. Implant the IOL with the most appropriate surgical procedure for the patient. Surgeons should verify that appropriate instrumentation is available prior to surgery. Refer to Table 2 for qualified combinations of compatible products.

**NOTE: During lens loading and insertion, DO NOT allow the Clareon™ IOL to remain in a folded condition within the selected IOL Delivery System for more than 3 minutes prior to completing insertion into the capsular bag.**

#### **MAGNETIC RESONANCE COMPATIBILITY**

The Clareon™ IOL is magnetic resonance (MR) Safe. The IOL consists of acrylate/methacrylate copolymer material, which is a non-conducting, non-metallic, non-magnetic material that poses no known hazards in all magnetic resonance imaging environments.

#### **PATIENT REGISTRATION**

The Patient Identification Card included in the package is to be completed and given to the patient, together with instructions to keep the card as a permanent record to be shown to any eye care practitioner that the patient consults in the future.

Each patient must be registered with Alcon Laboratories, Inc., immediately following implantation of one of these lenses. Registration is accomplished by completing the Implant Registration Card that is enclosed in the lens box and mailing it to Alcon Laboratories, Inc. Patient registration is essential for the long-term patient follow-up program and will assist Alcon Laboratories, Inc. in responding to reports of adverse events.

#### **SERIOUS INCIDENT REPORTING**

Any serious incident that may reasonably be regarded as device related should be reported to Alcon Laboratories, Inc.:

By Phone:

In USA - (800) 757-9780

Website:

<http://www.alcon.com/contact-us/>

Each IOL is identified by a serial number which provides traceability, and this information should be given to Alcon.

#### **EXPIRATION DATE**

Sterility is guaranteed unless the pouch is damaged or opened. The expiration date is clearly indicated on the outside of the lens package. Any lens held after the expiration date should be returned to Alcon Laboratories, Inc. (see RETURNED GOODS POLICY).

#### **RETURNED GOODS POLICY**

Returned lenses will only be accepted in exchange for other products, not credit. All returns must be accompanied by an Alcon Laboratories, Inc. Returned Goods Number and should be shipped via traceable means. A Returned Goods Number is obtained by contacting Alcon Laboratories, Inc. Customer Service Department. Issuance of this number does not constitute final acceptance of the returned products. For detailed policy guidelines including exchange, please contact your Sales or Customer Service Representative.

#### **CLINICAL STUDY OVERVIEW FOR Clareon™ ASPHERIC HYDROPHOBIC ACRYLIC IOL**

A prospective, multicenter, open-label clinical study in adult subjects requiring cataract surgery with IOL implantation was performed on the Clareon™ IOL in the United States. The objective of this study was to demonstrate favorable visual acuity and adverse event outcomes for the Clareon™ IOL compared to historical safety and performance endpoint (SPE) rates as reported in EN ISO 11979-7:2014. The results achieved by the subjects successfully followed for 12 Months postoperatively (defined as 330 to 420 days postoperative) provide reasonable assurance that the Clareon™ IOL is a safe and effective device for the visual correction of aphakia following cataract surgery.

A summary of the clinical study data is provided below to describe the performance characteristics of the IOL. Please use caution when comparing these results with results from similar device studies due to potential differences in patient cohorts, test methods, etc.

**Product: Clareon™ Aspheric Hydrophobic Acrylic IOL**  
**Model: SY60WF**

Note: Text in gray is for informational purposes only

**STUDY RESULTS FOR Clareon™ ASPHERIC HYDROPHOBIC ACRYLIC IOL**

The subject population in the clinical study consisted of 350 subjects in need of cataract surgery that were unilaterally implanted, the percentage of females (60.9%) exceeded the percentage of males (39.1%) enrolled. The mean age for the total population was 69.7 years.

Visual Acuity

The best corrected distance visual acuity (BCDVA) achieved at one year postoperatively by the Best Case Analysis Set is presented in **Table 5** and visual acuity achieved by All-Implanted Analysis Set is presented in **Table 6**. Similar data for BCDVA expressed as Snellen values are presented in **Tables 7** and **8**. The Best Case analysis included all eyes successfully implanted with the test article, had at least one postoperative visit, did not have any ocular pathology at Visit 0 (preoperative), had no macular degeneration at any visit, and did not have any previous surgery for the correction of refractive errors. All-Implanted Analysis set includes all eyes with successful test article implantation.

The one-sided exact 95% upper confidence limit for the percentage of subjects with monocular BCDVA of 0.3 logMAR or better at 12 months postoperative (Visit 5) is greater than or equal to the SPE rates as reported in EN ISO 11979-7:2014.

The uncorrected distance visual acuity (UCDVA) at one year postoperatively is presented in **Table 9** for the Best Case Analysis, and UCDVA achieved by All-Implanted Analysis Set is presented in **Table 10**.

**Table 5: Best Corrected Visual Acuity in the Best Case Analysis Set at Month 12, Clareon™ IOL**

Visual Acuity	n	%
0.0 logMAR or better	271	83.1
0.1 logMAR or better	307	94.2
0.2 logMAR or better	323	99.1
0.3 logMAR or better	325	99.7
Worse than 0.3 logMAR	1	0.3
ISO SPE Rate for % of 0.3 logMAR or better	96.7%	
N	326	
ISO SPE Rate = BS EN ISO 11979-7:2014, Ophthalmic Implants - Intraocular Lenses - Part 7: Clinical Investigations, Table B.4 - Posterior Chamber IOL Adverse Event Safety and Performance Endpoint Rates		

**Table 6: Best Corrected Visual Acuity in the All-Implanted Analysis Set at Month 12, Clareon™ IOL**

Visual Acuity	n	%
0.0 logMAR or better	277	81.0
0.1 logMAR or better	318	93.0
0.2 logMAR or better	339	99.1
0.3 logMAR or better	341	99.7
Worse than 0.3 logMAR	1	0.3
ISO SPE Rate for % of 0.3 logMAR or better	92.5%	
N	342	
ISO SPE Rate = BS EN ISO 11979-7:2014, Ophthalmic Implants - Intraocular Lenses - Part 7: Clinical Investigations, Table B.3 - Posterior Chamber IOL Adverse Event Safety and Performance Endpoint Rates		

**Table 7: Best Corrected Visual Acuity in the Best Case Analysis Set at Month 12 (Snellen), Clareon™ IOL**

Visual Acuity	n	%
20/20 or better	287	88.0
20/25 or better	316	96.9
20/32 or better	324	99.4
20/40 or better	325	99.7
Worse than 20/40	1	0.3
N	326	
Note: 20/20 = 0.04 logMAR      20/25 = 0.14 logMAR      20/32 = 0.24 logMAR 20/40 = 0.34 logMAR		

**Product: Clareon™ Aspheric Hydrophobic Acrylic IOL**  
**Model: SY60WF**

Note: Text in gray is for informational purposes only

**Table 8: Best Corrected Visual Acuity in the All-Implanted Analysis Set at Month 12 (Snellen), Clareon™ IOL**

<b>Visual Acuity</b>	<b>n</b>	<b>%</b>
20/20 or better	297	86.8
20/25 or better	331	96.8
20/32 or better	340	99.4
20/40 or better	341	99.7
Worse than 20/40	1	0.3
N	342	
Note: 20/20 = 0.04 logMAR      20/25 = 0.14 logMAR      20/32 = 0.24 logMAR 20/40 = 0.34 logMAR		

**Table 9: Uncorrected Visual Acuity in the Best Case Analysis Set at Month 12, Clareon™ IOL**

<b>Statistic</b>	<b>(N = 334)</b>
n	326
Mean (SD)	0.042 (0.1348)
Median	-0.02
(Min, Max)	(-0.20, 0.70)
95% CI	(-0.027, -0.056)

**Table 10: Uncorrected Visual Acuity in the All-Implanted Analysis Set at Month 12, Clareon™ IOL**

<b>Statistic</b>	<b>(N = 350)</b>
n	342
Mean (SD)	0.043 (0.1339)
Median	0.02
(Min, Max)	(-0.20, 0.70)
95% CI	(0.029, 0.057)

**Product: Clareon™ Aspheric Hydrophobic Acrylic IOL  
Model: SY60WF**

Note: Text in gray is for informational purposes only

Adverse Events

The cumulative and persistent adverse events rates for the Safety Analysis Set are presented in **Table 11**. Cumulative adverse events are those that occur at any point in the study while persistent adverse events are those that occur or are ongoing at the 12 Month Visit. The Safety Analysis Set included all eyes with attempted implantation with the test article (successful or aborted after contact with the eye). In this study, the number of eyes in the Safety Analysis Set was equivalent to the All-Implanted Analysis Set.

For both cumulative and persistent adverse events, the exact one-sided 95% lower confidence limit of cumulative and persistent adverse events were within limits compared to the SPE rates reported in EN ISO 11979-7:2014.

**Table 11: Cumulative and Persistent Adverse Events in the Safety Analysis Set, Clareon™ IOL**

	(N = 350)			
	n (%)	2-sided 95% CI	1-sided 95% Lower CL	SPE %
<b>Cumulative Serious Adverse Events</b>				
Cystoid macular oedema	3 (0.9)	(0.18, 2.48)	0.23	3.0
Hypopyon	0 (0.0)	(0.00, 1.05)	0.00	0.3
Endophthalmitis	0 (0.0)	(0.00, 1.05)	0.00	0.1
Lens dislocated from posterior chamber	0 (0.0)	(0.00, 1.05)	0.00	0.1
Pupillary block	0 (0.0)	(0.00, 1.05)	0.00	0.1
Retinal detachment	0 (0.0)	(0.00, 1.05)	0.00	0.3
Secondary surgical intervention*	6 (1.7)	(0.63, 3.69)	0.75	0.8
<b>Other</b>				
Herpes virus infection	1 (0.3)	(0.01, 1.58)	0.01	NA
Macular fibrosis	1 (0.3)	(0.01, 1.58)	0.01	NA
Macular hole	1 (0.3)	(0.01, 1.58)	0.01	NA
Punctate keratitis	1 (0.3)	(0.01, 1.58)	0.01	NA
Retinal tear	2 (0.6)	(0.07, 2.05)	0.10	NA
<b>Persistent Serious Adverse Events</b>				
Corneal stroma oedema	0 (0.0)	(0.00, 1.05)	0.00	0.3
Cystoid macular oedema	1 (0.3)	(0.01, 1.58)	0.01	0.5
Iritis	0 (0.0)	(0.00, 1.05)	0.00	0.3
Raised IOP requiring treatment	0 (0.0)	(0.00, 1.05)	0.00	0.4
CI = Confidence Interval CL = Confidence Limit SPE = Safety and Performance Endpoint Persistent = Present or ongoing at the final scheduled visit IOP = Intraocular Pressure SPE rates are from BS EN ISO 11979-7:2014, Ophthalmic Implants - Intraocular Lenses - Part 7: Clinical Investigations, Table B.2 - Posterior Chamber IOL Adverse Event Safety and Performance Endpoint Rates If an eye has multiple occurrences of an AE, the eye is presented only once in the respective eye count column (n) for the corresponding AE. "Other" includes the MedDRA Preferred Term for ocular SAEs that do not belong to any predefined SPE categories. Percentages are calculated as (n/N) * 100. The SPE rate is considered not exceeded if the 1-sided 95% lower CL for an AE is less than the SPE%. *None of these secondary surgical interventions were related to the IOL.				

IOL Observations

At all five scheduled postoperative visits and at unscheduled visits, slit-lamp examinations were performed. The list of pre-specified slit-lamp findings included IOL observations, which were described as IOL glistenings, scratches/cracks on the IOL, and surface haze on the IOL. Across 1,852 postoperative (including unscheduled) visits, no IOL observations (IOL glistenings, scratches/cracks on the IOL, and surface haze on the IOL) were noted for the Clareon™ IOL.

**REFERENCES**

Boettner, E.A. and Wolter, J.R. Transmission of the ocular media. *Invest. Ophthalmol.* 1962;1:776-83.

**Product: Clareon™ Aspheric Hydrophobic Acrylic IOL**  
**Model: SY60WF**

Note: Text in gray is for informational purposes only

Haigis W. ULIB - User group for Laser Interference Biometry. Updated 2014 Jul 17; cited 2015 Mar 13. Available at: <http://ocusoft.de/ulib/>.

Hoffer KJ. The Hoffer Q formula: a comparison of theoretic and regression formulas. *J Cataract Refract Surg.* 1993;19(6):700-12.

Holladay JT. Standardizing constants for ultrasonic biometry, keratometry, and intraocular lens power calculations. *J Cataract Refract Surg.* 1997;23(9):1356-70.

Olsen T. Calculation of intraocular lens power: a review. *Acta Ophthalmol Scand.* 2007;85(5):472-85.

Retzlaff JA, Sanders DR, Kraff M. *Lens Implant Power Calculation.* 3rd ed. Thorofare (NJ): Slack, Inc.; 1990.

**STAND ALONE SYMBOLS FROM ISO 7000/ISO 7001<sup>‡</sup> USED ON LABELING**  
**(ISO 7000 Title: Graphical Symbols for Use on Equipment)**  
**(<sup>‡</sup>ISO 7001 Title: Graphical symbols – Public information symbols)**







Symbol	Reference Number from ISO 7000 / ISO 7001 <sup>‡</sup>	Symbol Title / Explanatory Text
	1051	Do not re-use
	2608	Do not re-sterilize
	2607	Use-by date
	2501	Sterilized using ethylene oxide
	2498	Serial number
	2493	Catalogue number
	0434A	Caution
	3082	Manufacturer
	0533	Upper limit of temperature
	1641	Consult instructions for use
	3500	Electronic instructions for use
	2606	Do not use if package has been damaged
	2497	Date of Manufacture
	3079	Open Here
	3010	RFID tag, general
	5662	Date
	PI PF 002 <sup>‡</sup>	Hospital

<sup>‡</sup>This symbol is the only one from ISO 7001 in the table above.

**Product: Clareon™ Aspheric Hydrophobic Acrylic IOL  
Model: SY60WF**

Note: Text in gray is for informational purposes only

**ABBREVIATIONS or SYMBOLS USED ON LABELING**

Abbreviation or Symbol	Symbol Title / Explanatory Text
<b>MD</b>	Medical device
	Single sterile barrier system
IOL	Intraocular lens
OVD	Ophthalmic viscosurgical device
	UV and Blue Light Filter
	Posterior chamber IOL
UV	Ultraviolet
D	Diopter
$\varnothing_B$	Body diameter (Optic diameter)
$\varnothing_T$	Overall diameter (Overall length)
L	Left
R	Right
PWR	Spherical Equivalent Power
	D-size nozzle for MONARCH™ cartridge*
	C-size nozzle for MONARCH™ cartridge*
	Not made with natural rubber latex
	Does not contain PHT (phthalates)
<b>MR</b>	MR Safe
<b>Rx only</b>	Caution: Federal (USA) Law restricts this device to sale by or on the order of a physician
<b>EC REP</b>	Authorized Representative in the European Community
*The recommendation shown on the labeling is for the smallest qualified cartridge nozzle size per diopter. For all qualified combinations of products, please review <b>Table 2</b> .	



Alcon Laboratories, Inc.  
6201 South Freeway  
Fort Worth, Texas 76134-2099 USA

† Trademarks are the property of their respective owners.

**ALCON** (current approved logo)

<Insert copyright>



**Clareon™ Toric Aspheric Hydrophobic Acrylic IOL  
w/ the AutonoMe™ Automated Pre-loaded Delivery System  
Model: CNA0T3-CNA0T9**

NOTE: Text appearing in gray is for information purposes only.

Directions for Use

<Note: Include revision date on approved DFU using YYYY-MM format>



<https://ifu.alcon.com>

XX-XXX-XXX-XXX (Insert Commodity Number)

**PRODUCT INFORMATION**

Alcon Laboratories, Inc.

Clareon™ Toric Aspheric Hydrophobic Acrylic IOL  
with the AutonoMe™ Automated Pre-loaded Delivery System (logo)

**STERILE UV and Blue Light Filtering Acrylic Foldable Toric Aspheric Single-Piece  
Posterior Chamber Intraocular Lenses with the AutonoMe™ Automated Pre-loaded Delivery System**



**DESCRIPTION**

The Clareon™ Toric Aspheric Hydrophobic Acrylic IOL (henceforth referred to as Clareon™ Toric IOL, Models CNW0T3-CNW0T9) is provided in the AutonoMe™ Automated Pre-loaded Delivery System (henceforth referred to as AutonoMe™ Delivery System, Models CNA0T3-CNA0T9) for a convenient, controlled means to reliably place the IOL into the capsular bag. The Clareon™ Toric IOL is an ultraviolet and blue light filtering foldable single-piece posterior chamber intraocular lens. Each lens has an optical portion and mechanical support elements (haptics) composed of a high refractive index soft hydrophobic acrylic material capable of being folded prior to insertion, which contains a covalently bonded blue light filtering chromophore. Alcon's proprietary chromophore filters blue light in a manner that approximates the human crystalline lens in the 400 to 475 nm wavelength range (Boettner and Wolter, 1962). The optic portion is biconvex and includes an aspheric surface. After surgical insertion into the eye, the lens gently unfolds to a full-size lens body. The haptics provide proper positioning of the lens optic within the capsular bag.

The anterior aspheric surface of the Clareon™ Toric IOL is designed with negative spherical aberration to compensate for the positive spherical aberration of an average cornea. The effects of this aspheric design feature have not been clinically assessed on the Clareon™ Toric IOL. Additionally, these IOLs have a toric component on the posterior surface with axis marks to denote the flat meridian (plus cylinder axis). Alignment of the toric axis marks with the post-operative steep corneal meridian allows the lens to correct preexisting corneal astigmatism.

The AutonoMe™ Delivery System is a single-use lens case and injector delivery system. This device arrives fully assembled with the IOL positioned within the lens bay. It features a speed-control-lever user interface that allows single-handed IOL delivery. IOL advancement is driven by an internal compressed gas cylinder, which provides speed modulation by varying speed-control-lever depression. The physical properties of this lens and delivery system are described in **Figures 1, 2, and 3** and **Table 1**.

**Table 1: Physical Characteristics of Clareon™ Toric IOLs**

Physical Characteristics	Description						
	Preloaded IOL Model	CNA0T3	CNA0T4	CNA0T5	CNA0T6	CNA0T7	CNA0T8
Optic Type	Biconvex Toric Aspheric Optic						
Optic Material	Ultraviolet and Blue Light Filtering Hydrophobic Acrylate/Methacrylate Copolymer						
Spectral Transmission	10% transmittance at 403 nm (UV) for +20.0 diopter IOL						
Index Of Refraction	1.55 at 35°C						
Optic Powers	+6.0 to +30.0 diopters (in 0.5 diopter increments)						
IOL Cylinder Powers (D)	1.50	2.25	3.00	3.75	4.50	5.25	6.00
Haptic Configuration	STABLEFORCE™ Modified-L Haptics						
Haptic Material	Ultraviolet and Blue Light Filtering Hydrophobic Acrylate/Methacrylate Copolymer						
Optic Diameter Ø <sub>B</sub> (mm)	6.0						
Overall Length Ø <sub>T</sub> (mm)	13.0						
Haptic Angle	0°						

**Clareon™ Toric Aspheric Hydrophobic Acrylic IOL  
w/ the AutonoMe™ Automated Pre-loaded Delivery System  
Model: CNA0T3-CNA0T9**

NOTE: Text appearing in gray is for information purposes only.

**HOW SUPPLIED**

Clareon™ Toric Aspheric Hydrophobic Acrylic IOLs are supplied dry and in the AutonoMe™ Delivery System, which is contained within a package terminally sterilized with ethylene oxide. The primary sterilization package must be opened only under aseptic conditions (see DIRECTIONS FOR USE).

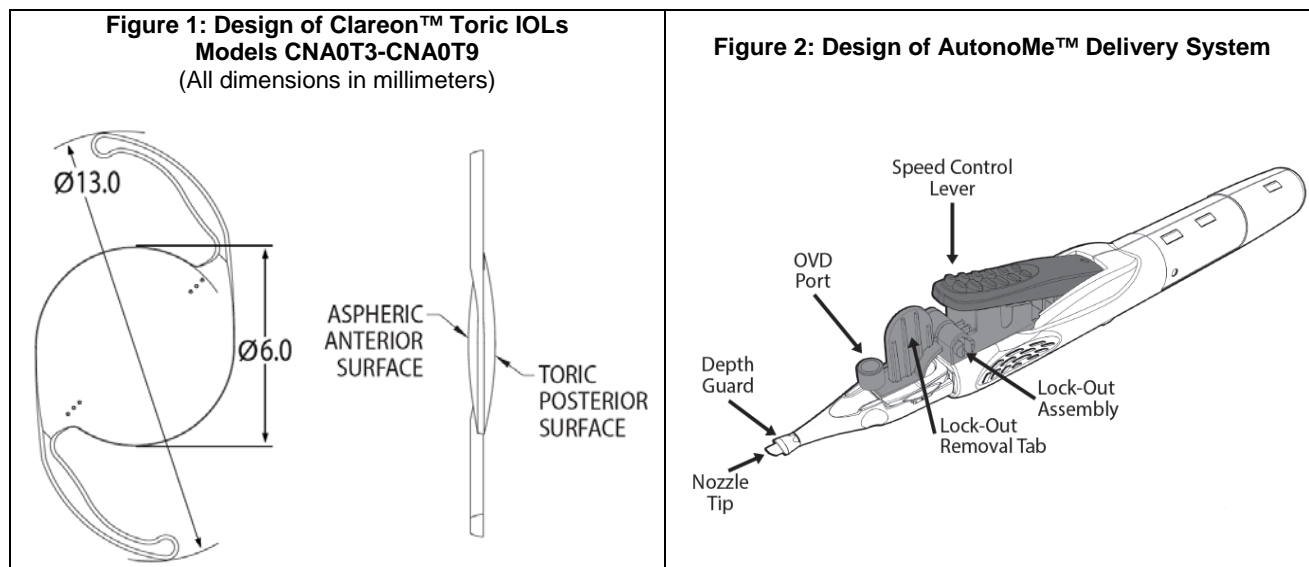

**Figure 3: Spectral Transmittance**

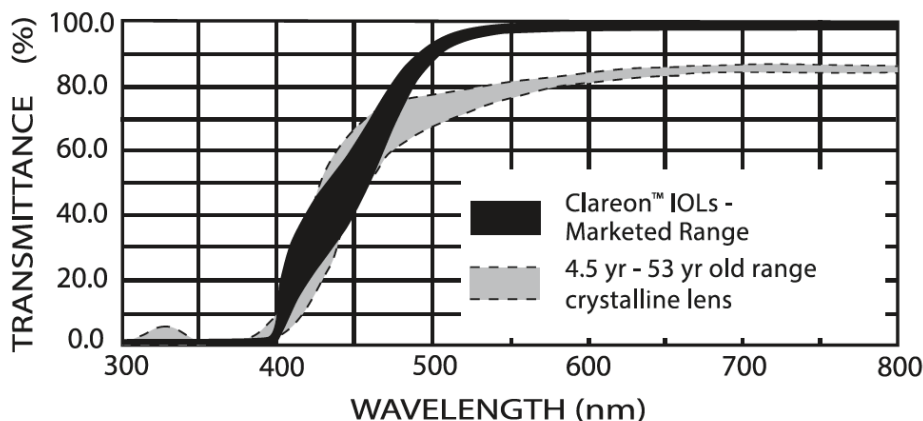

**NOTES:**

- The cutoff wavelength and the spectral transmittance curves presented here represent the range of transmittance values of IOLs made from hydrophobic acrylate/methacrylate copolymer with bonded UV-absorber and Alcon's proprietary blue light filtering chromophore.
- Measurements were by direct transmittance using Clareon™ IOLs with center thickness equivalent to the marketed range.
- Human lens data from Boettner and Wolter (1962).

**MODE OF ACTION (INTENDED USE)**

The Clareon™ Toric IOL with the AutonoMe™ Delivery System provides a means to insert the IOL into the capsular bag in a controlled manner. The Clareon™ Toric IOL is intended for use by a trained ophthalmic surgeon. The IOL is intended to be placed in the capsular bag in the posterior chamber of the eye, replacing the natural crystalline lens. This position allows the IOL to function as a refractive medium in the correction of aphakia and pre-

**Clareon™ Toric Aspheric Hydrophobic Acrylic IOL  
w/ the AutonoMe™ Automated Pre-loaded Delivery System  
Model: CNA0T3-CNA0T9**

NOTE: Text appearing in gray is for information purposes only.

existing corneal astigmatism. The aspheric biconvex toric optic compensates for the positive spherical aberration of the cornea as compared to a standard spherical optic. These IOLs have a toric optic with cylinder axis marks to denote the flat meridian (plus cylinder axis). Alignment of the toric axis marks with that of the postoperative steep corneal meridian allows this lens to reduce preexisting corneal astigmatism. The astigmatic correction at the corneal plane for each Clareon™ Toric IOL model is shown in **Table 2**.

**Table 2: Astigmatic Correction at the Corneal Plane for Clareon™ Toric IOLs**

IOL Model	Cylinder Power	
	IOL Power (Diopters)	Corneal Plane (Diopters) <sup>a</sup>
CNA0T3	1.50	0.98
CNA0T4	2.25	1.47
CNA0T5	3.00	1.96
CNA0T6	3.75	2.45
CNA0T7	4.50	2.94
CNA0T8	5.25	3.43
CNA0T9	6.00	3.92

<sup>a</sup>Based on an average pseudophakic human eye using an SRK/T optical A-constant of 119.1

**INDICATIONS**

The Clareon™ Toric Aspheric Hydrophobic Acrylic Intraocular Lenses (IOLs) are indicated for primary implantation in the capsular bag in the posterior chamber of the eye for visual correction of aphakia and pre-existing corneal astigmatism to reduce residual refractive cylinder and improve uncorrected distance vision in adult patients in whom a cataractous lens has been removed.

**DEVICE PREPARATION AND IOL IMPLANTATION**

To accommodate the full diopter range of the Clareon™ Toric IOLs, the AutonoMe™ Delivery System is supplied with an AutonoMe™ Nozzle or an AutonoMe™ C-size Nozzle depending on the IOL diopter. **Table 3** shows the combination of nozzle size and IOL diopter range.

**Table 3: Combinations of Nozzle Size and IOL Diopter Range**

Lens Model	Diopter Range	Nozzle Size
CNA0T3	6.0 - 25.0 D	AutonoMe™ Nozzle
	25.5 – 30.0 D	AutonoMe™ C-size Nozzle
CNA0T4-CNA0T6	6.0 - 21.0 D	AutonoMe™ Nozzle
	21.5 – 30.0 D	AutonoMe™ C-size Nozzle
CNA0T7-CNA0T9	6.0 - 18.0 D	AutonoMe™ Nozzle
	18.5 – 30.0 D	AutonoMe™ C-size Nozzle

During implantation of Clareon™ Toric IOL, an Alcon qualified OVD should be used. The use of an unqualified OVD may cause damage to the lens and potential complications during the implantation process. The qualified OVDs that can be used with a Clareon™ Toric IOL are listed in **Table 4**.

**Table 4: Qualified OVDs for Use with the Clareon™ Toric IOL in the AutonoMe™ Delivery System**

Models	Qualified OVD
CNA0T3-CNA0T9	VISCOAT™ OVD DISCOVISC™ OVD PROVISC™ OVD

**CALCULATION OF LENS POWER**

Accurate biometry is essential for successful visual outcomes. Preoperative calculation of required lens power for the Clareon™ Toric IOL should be determined by the surgeon's experience and preference. A reference SRK/T A-Constant value for optical biometry equipment such as IOLMaster<sup>®</sup> or LenStar<sup>®</sup> as well as *contact* ultrasound biometry is listed on the outer label. The reference optical A-Constant anticipates the use of both corneal power and axial length values from optical biometry equipment with standard settings for a typical patient population and a spectacle far point at 6 meters. In general, A-constants must be "personalized" to compensate for such things as

**Clareon™ Toric Aspheric Hydrophobic Acrylic IOL  
w/ the AutonoMe™ Automated Pre-loaded Delivery System  
Model: CNA0T3-CNA0T9**

NOTE: Text appearing in gray is for information purposes only.

---

differences in instrumentation, surgical techniques, and IOL power calculation that may exist between clinical practices. IOL power calculation methods are often included with biometry equipment, and they are also described in the references (Hoffer 1993; Holladay 1997; Olsen 2007; Retzlaff, Sanders & Kraff 1990; Haigis 2014).

#### **WARNINGS**

1. The Clareon™ Toric IOL is intended for implantation in the capsular bag only. There are no clinical data to demonstrate its safety and effectiveness for placement in the ciliary sulcus.
2. DO NOT re-sterilize the Clareon™ Toric IOL or the AutonoMe™ Delivery System by any method.
3. DO NOT implant the IOL if the sterility has been compromised or if the sterile package has been unintentionally opened before use.
4. DO NOT reuse the Clareon™ Toric IOL or AutonoMe™ Delivery System. The device is for single use only. Reuse of this single-use device may result in serious injury, such as but not limited to endophthalmitis.
5. Physicians considering lens implantation under any of the following circumstances should weigh the potential risk/benefit ratio: Patients in whom the posterior capsule is ruptured, zonules are damaged, or primary posterior capsulotomy is planned.
6. Rotation of the Clareon™ Toric IOL away from its intended axis can reduce the astigmatic correction. Each degree of misalignment of a toric IOL may reduce the cylinder power effect by approximately 3.3% (Ma 2008). If IOL repositioning is necessary, it should occur as early as possible, prior to IOL encapsulation. Some clinical cases suggest encapsulation is complete within four weeks of implantation.
7. It is recommended that OVD be removed from the eye at the close of surgery with emphasis on the space between the posterior capsule and lens. This may be accomplished by gently depressing the IOL optic posteriorly with the I/A tip and using standard irrigation/aspiration techniques to remove the OVD from the eye. This should force any trapped OVD anteriorly where it can be easily aspirated. Residual OVD may allow the lens to rotate causing misalignment of the Clareon™ Toric IOL with the intended axis of placement.

#### **PRECAUTIONS**

1. A high level of surgical skill is required for intraocular lens implantation. The surgeon should have observed and/or assisted in numerous implantations and successfully completed one or more courses on intraocular lens implantation before attempting to implant intraocular lenses.
2. Prior to surgery, prospective patients should be informed of the possible risks and benefits associated with this IOL as well as the risks and benefits associated with cataract surgery. After surgery, physicians should provide an implant card to patients regarding the IOL implanted.
3. The safety and effectiveness of the Clareon™ Toric IOL has not been substantiated in clinical trials in patients with certain pre-existing conditions and/or intraoperative conditions (listed in **Tables 5** and **6**) as these patients were excluded from the clinical studies. Patients with pre-existing conditions may not achieve the visual acuity of patients without such conditions. As with the implantation of any IOL, careful preoperative evaluation and sound clinical judgment should be used by the surgeon to decide the benefit/risk ratio before implanting a lens in a patient with one or more of these conditions.
4. Do not store the Clareon™ Toric IOL and the AutonoMe™ Delivery System at temperatures over 30 °C (86 °F).
5. Use the AutonoMe™ Delivery System at Operating Room temperatures between 18 °C (64 °F) and 23 °C (73 °F) after the device has been allowed to come to the operating room temperature over a 30 minute timeframe.
6. Once the lens is in position at the pause location on the nozzle, the lens should be implanted within 1 minute. Failure to adhere to manufacturer's recommendations may result in IOL damage.
7. Once the package is opened, handle the AutonoMe™ Delivery System with care. DO NOT use a system that has been accidentally dropped as internal or external device components may be damaged, and the damage may not be visible with inspection.
8. DO NOT use the device if it is activated prior to OVD addition as IOL damage may occur.
9. Contents are under pressure. DO NOT attempt to disassemble the device or alter it in any way.
10. Accurate keratometry and biometry, in addition to the use of the Toric Calculator for the Clareon™ Toric IOL models (<http://www.myalcon-toriccalc.com>), are recommended to achieve optimal visual outcomes.
11. For models CNA0T6 to CNA0T9, patients with postoperative refractive error may not receive the aspheric optical design benefit without spectacle correction.
12. For models CNA0T6 to CNA0T9, optical theory suggests that high astigmatic patients may experience spatial distortions. Possible toric IOL related factors may include residual cylindrical error or axis misalignments.
13. As with any surgical procedure, there is risk involved. Potential complications accompanying cataract and/or IOL implantation surgery may include, but are not limited to, the following: lens epithelial cell on-

**Clareon™ Toric Aspheric Hydrophobic Acrylic IOL  
w/ the AutonoMe™ Automated Pre-loaded Delivery System  
Model: CNA0T3-CNA0T9**

NOTE: Text appearing in gray is for information purposes only.

growth, corneal cell endothelial damage, infection (endophthalmitis), toxic anterior segment syndrome (TASS), retinal detachment, vitritis, cystoid macular edema, corneal edema, pupillary block, cyclitic membrane, iris prolapse, hypopyon, anterior uveitis, hyphema, pigment dispersion, posterior capsule opacification, transient or persistent glaucoma, and secondary surgical interventions. Secondary surgical interventions include, but are not limited to: lens repositioning, lens replacement, vitreous aspiration or iridectomy for pupillary block, wound leak repair, and retinal detachment repair.

**Table 5: Preexisting Conditions with No Safety and Effectiveness Data**

<ul style="list-style-type: none"> <li>• Clinically severe corneal dystrophy (e.g., epithelial, stromal, or endothelial dystrophy), keratitis, keratoconjunctivitis, keratouveitis, keratopathy, or kerectasia</li> <li>• Irregular corneal astigmatism</li> <li>• Previous corneal transplant</li> <li>• Aniridia</li> <li>• Iris neovascularization</li> <li>• Uncontrolled glaucoma</li> <li>• Rubella, congenital, traumatic, or complicated cataracts</li> <li>• Extremely shallow anterior chamber, not due to swollen cataract</li> <li>• Clinically significant macular degeneration</li> <li>• Previous retinal detachment</li> <li>• Diabetic retinopathy</li> </ul>	<ul style="list-style-type: none"> <li>• Optic nerve atrophy</li> <li>• Recurrent anterior or posterior segment inflammation of unknown etiology, or any disease producing an inflammatory reaction in the eye (e.g., iritis or uveitis)</li> <li>• Amblyopia</li> <li>• Pre-existing ocular conditions which may negatively impact stability of the implant (e.g., diagnosis of pseudoexfoliation syndrome)</li> <li>• Microphthalmos</li> <li>• Previous corneal or refractive surgery</li> <li>• Current or previous usage of alpha-1-selective adrenoceptor blocking agent or antagonist of alpha 1A adrenoceptor [e.g., Flomax<sup>†</sup> (tamsulosin HCL), Hytrin<sup>†</sup>, or Cardura<sup>†</sup>]</li> <li>• Pregnancy</li> </ul>
--	---

**Table 6: Intraoperative Conditions with No Safety and Effectiveness Data**

<ul style="list-style-type: none"> <li>• Other additional procedures during cataract surgery due to intraoperative complications that require further intervention (e.g., posterior rupture with vitreous loss)</li> <li>• Excessive iris mobility</li> <li>• Mechanical or surgical manipulation required to enlarge the pupil</li> </ul>	<ul style="list-style-type: none"> <li>• Vitreous loss (significant)</li> <li>• Anterior chamber bleeding (significant)</li> <li>• Complications in which the IOL stability could be compromised, including but not limited to zonular or capsular rupture or zonular weakness</li> <li>• Inability to place IOL in capsular bag due to surgical complications</li> </ul>
--	---

**SELECTION OF TORIC IOL**

For selection of the appropriate toric IOL, Alcon provides a web-based tool ([www.myalcon-toriccalc.com](http://www.myalcon-toriccalc.com), Abulafia, Barrett, et al. 2015 and Abulafia, Hill, et al. 2015) that uses pre-operative biometry data, incision location, and surgically induced corneal astigmatism. The astigmatism to be corrected should be determined from biometry data rather than refractive data since the presence of lenticular astigmatism in the crystalline lens to be removed may influence results.

**AXIS PLACEMENT OF TORIC IOL**

For optimal results, the surgeon must ensure the correct placement and orientation of the lens within the capsular bag. The posterior surface of the IOL is marked with indentations (three at each end) at the haptic/optic junction that identify the flat meridian of the toric IOL optic. These indentations form an imaginary line representing the plus cylinder axis (note: IOL cylinder steep meridian is 90° away). The cylinder axis marks should be aligned with the post-incision steep corneal meridian (intended axis of placement) or as determined by the web-based IOL calculator.

Prior to surgery, the lens placement axis should be marked. One way used in clinical practice to mark the eye is as follows: With the patient sitting upright to prevent cyclotorsion, clearly and precisely mark two reference positions with a surgical skin marker or a marking pencil indicated for ophthalmic use. Using these marks as reference points, an axis marker can be used immediately prior to or during surgery to mark the optimal axis of lens placement identified by the web-based IOL calculator ([www.myalcon-toriccalc.com](http://www.myalcon-toriccalc.com)).

Precisely align the axis marking indentations on the toric IOL with the marked intended axis of lens placement. Remove all OVD from both the anterior and posterior sides of the lens since residual OVD may allow the lens to

**Clareon™ Toric Aspheric Hydrophobic Acrylic IOL  
w/ the AutonoMe™ Automated Pre-loaded Delivery System  
Model: CNA0T3-CNA0T9**

NOTE: Text appearing in gray is for information purposes only.

---

rotate causing misalignment of the toric IOL with the intended axis of placement. This may be accomplished by manipulating the IOL optic with the I/A tip and using standard irrigation/aspiration techniques to remove all OVD from the eye. Bimanual techniques may be used, if preferred, to ensure removal of OVD from behind the lens implant. Special care should be taken to ensure proper positioning of the toric IOL at the intended axis following OVD removal.

Misalignment of the axis of the lens versus the intended axis of placement may compromise its astigmatic correction. Such misalignment can result from inaccurate keratometry or marking of the cornea, inaccurate placement of the toric IOL axis during surgery, an unanticipated surgically induced change in the cornea, or physical rotation of the toric IOL after implantation. In order to minimize this effect, the surgeon should be careful to ensure that preoperative keratometry and biometry is accurate and that the IOL is properly oriented prior to the end of surgery.

#### **DIRECTIONS FOR USE**

Step 1. Examine the label on the outer box for model, spherical equivalent power, cylinder power, proper configuration, and expiration date.

Step 2. After the outer box is open, inspect the device package for any damage.

**NOTE:** If damage is observed, use another Clareon™ Toric IOL and AutonoMe™ Delivery System.

Step 3. Verify that the lens information on the device label (e.g., model, powers, and serial number) is consistent with the information on the outer box labeling.

Step 4. Remove the AutonoMe™ Delivery System by gripping the corner of the plastic tray and peeling open the TYVEK† material lid portion fully.

Step 5. Transfer the device to a sterile environment.

**NOTE:** Ensure that the AutonoMe™ Delivery System has been allowed to come to the operating room temperature over a 30 minute timeframe prior to use.

Step 6. Inspect the device nozzle for damage, particulates, or deformation. Ensure that the device is completely intact and that the plunger and lock-out assembly have not been moved.

**NOTE:** If the device does not pass the inspection criteria, use another Clareon™ Toric IOL and AutonoMe™ Delivery System.

Step 7. Fully insert the cannula containing OVD through the OVD port, and ensure that the cannula is perpendicular to the device as shown in **Figure 4**.

**NOTE:** Ensure that the Alcon qualified OVD has been allowed to come to the operating room temperature over a 20 minute timeframe prior to use. Only use an Alcon qualified OVD (see **Table 4**).

**!IMPORTANT: PERFORM Steps 8, 9, 10, AND 11 IN SEQUENCE, WITH MINIMAL DELAY BETWEEN STEPS.**

Step 8. Fill the device until OVD can be observed flowing to the nozzle tip (**Figure 4**), then retract the cannula. This will require approximately 0.28 mL of OVD.

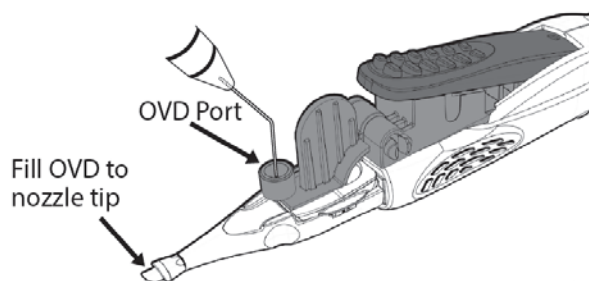

**Figure 4**

**Clareon™ Toric Aspheric Hydrophobic Acrylic IOL  
w/ the AutonoMe™ Automated Pre-loaded Delivery System  
Model: CNA0T3-CNA0T9**

NOTE: Text appearing in gray is for information purposes only.

---

Step 9. Remove the lock-out assembly by grasping the removal tab and directly pulling the entire lock-out assembly away from the device at an angle (**Figure 5**). Discard the lockout assembly.

**NOTE:** Do not attempt to add OVD to the device after the lock-out assembly has been removed, or lens damage may result. Take care not to depress the Speed Control Lever until ready to advance the IOL (Step 10).

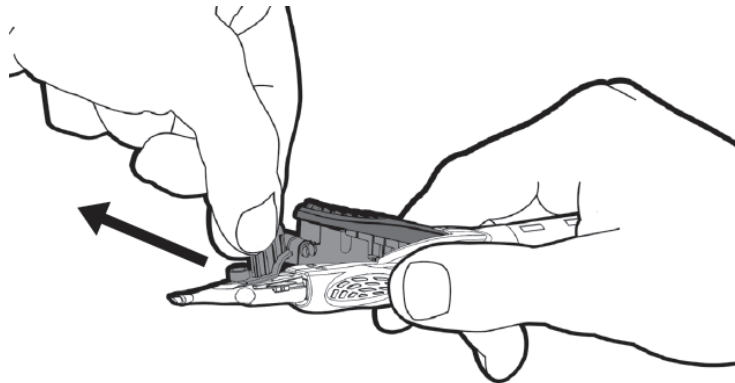

**Figure 5**

Step 10. Fully depress the Speed Control Lever to move the plunger forward and fold the IOL (**Figure 6a**). To stop the IOL, release the Speed Control Lever when the front edge of the optic is even with the pause location on the nozzle (**Figure 6b**).

**NOTE:** The AutonoMe™ Delivery System is a pneumatic device. Thus, a click may be heard as the Speed Control Lever is initially depressed, and the device is activated.

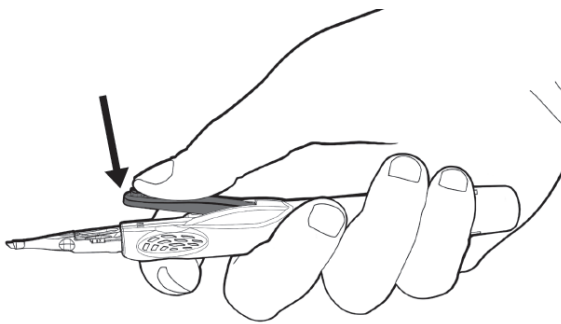

**Figure 6a**

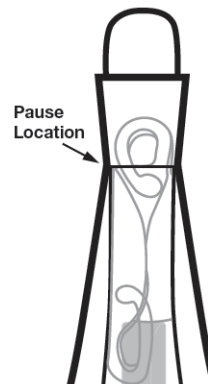

**Figure 6b**

Step 11. Visually inspect the lens to determine the position of the leading and trailing haptics (Refer to **Figure 7**). Verify that the plunger is in contact with the trailing optic edge.

**NOTE:** Once the lens is in position at the pause location on the nozzle, **the lens should be implanted within 1 minute.**

**!!IMPORTANT: DO NOT IMPLANT LENS IF THE HAPTIC EXITS NOZZLE PRIOR TO INSERTION THROUGH INCISION.**



Clareon™ Toric Aspheric Hydrophobic Acrylic IOL  
w/ the AutonoMe™ Automated Pre-loaded Delivery System  
Model: CNA0T3-CNA0T9

NOTE: Text appearing in gray is for information purposes only.

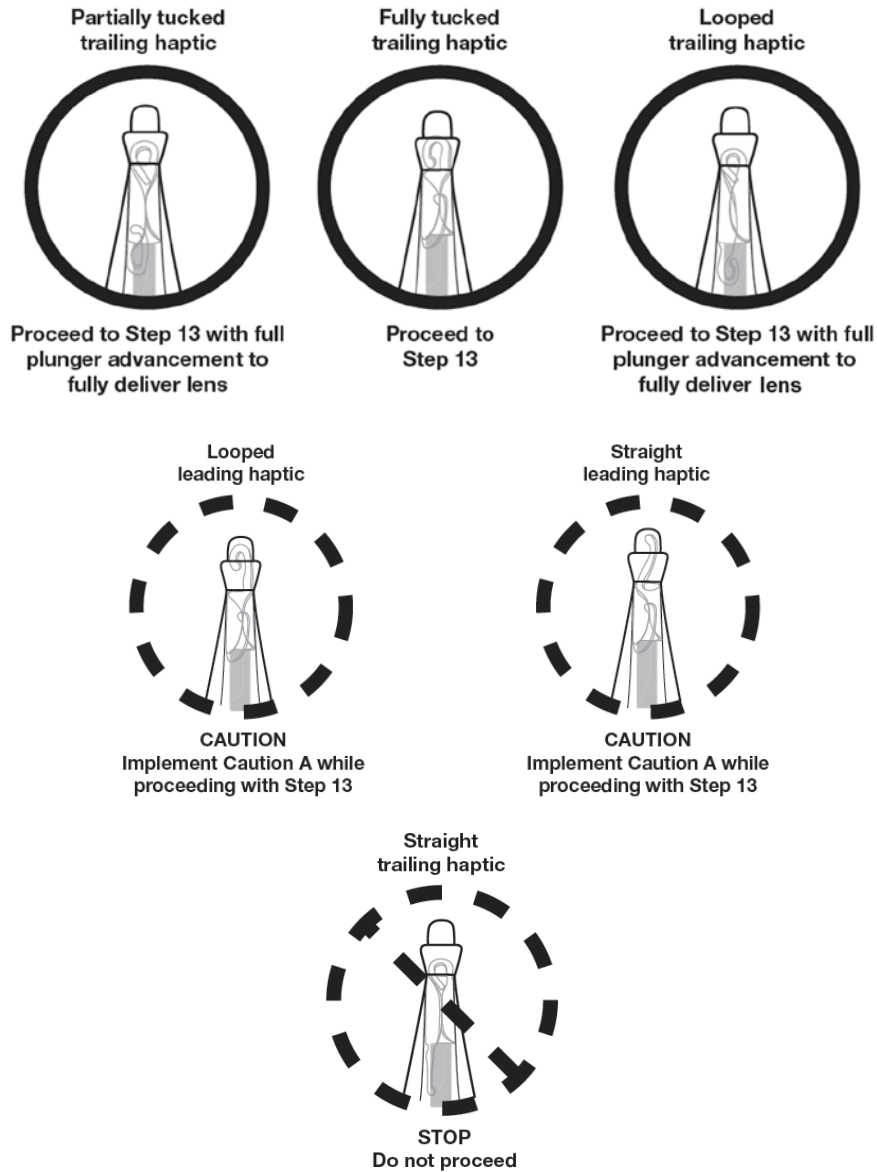

**Figure 7**

**NOTE:** In the three acceptable trailing haptic configurations shown above (denoted by the solid circles), different leading haptic configurations are also shown; all configurations shown are acceptable to proceed.

**CAUTION A:** If the leading haptic is straight or looped and extended in front of the lens, rotate device clockwise to bevel left before advancing plunger to ensure the leading haptic is correctly placed in the capsular bag. In order to ensure that the lens unfolds anterior side up within the capsular bag, rotate the device back to center or slightly bevel right as the optic exits the nozzle.

Step 12. Refer to **Table 3**. The higher spherical power IOLs are provided with the C-size nozzle (denoted by a “C” on the top of the nozzle, as shown in **Figure 8b**). Confirm an appropriate incision for the corresponding nozzle size prior to lens implantation.

Step 13. Insert the nozzle tip into the incision as far as needed to facilitate lens implantation, using the depth guard (**Figures 8a** and **8b**) as the insertion limit, and aim the nozzle tip at the anterior capsule opening.



**Clareon™ Toric Aspheric Hydrophobic Acrylic IOL  
w/ the AutonoMe™ Automated Pre-loaded Delivery System  
Model: CNA0T3-CNA0T9**

NOTE: Text appearing in gray is for information purposes only.

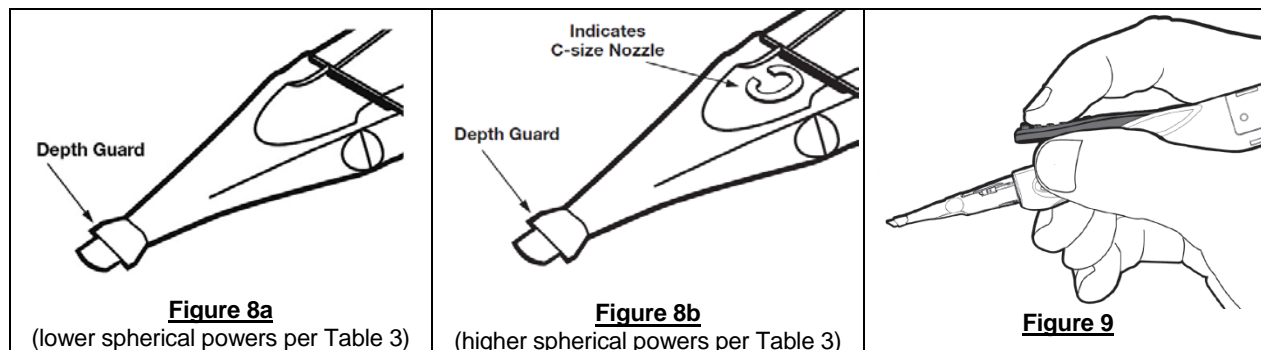

Step 14. Advance the plunger by depressing the Speed Control Lever (Refer to **Figure 9**). Maintain adequate pressure to ensure the nozzle tip remains in the incision. Plunger speed can be varied by the amount that the Speed Control Lever is depressed. The plunger can be stopped at any time by releasing the Speed Control Lever.

Step 15. Use a suitable positioning instrument to position the lens within the capsular bag and in a planar fashion parallel to the iris.

Step 16. Safely discard the entire device as medical waste in accordance with local laws and regulations.

#### **MAGNETIC RESONANCE COMPATIBILITY**

The Clareon™ Toric IOL is magnetic resonance (MR) Safe. The IOL consists of acrylate/methacrylate copolymer material, which is a non-conducting, non-metallic, non-magnetic material that poses no known hazards in all magnetic resonance imaging environments.

#### **PATIENT REGISTRATION**

The Patient Identification Card included in the package is to be completed and given to the patient, together with instructions to keep the card as a permanent record to be shown to any eye care practitioner that the patient consults in the future.

Each patient must be registered with Alcon Laboratories, Inc., immediately following implantation of one of these lenses. Registration is accomplished by completing the Implant Registration Card that is enclosed in the lens box and mailing it to Alcon Laboratories, Inc. Patient registration is essential for the long-term patient follow-up program and will assist Alcon Laboratories, Inc. in responding to reports of adverse events.

#### **SERIOUS INCIDENT REPORTING**

Any serious incident that may reasonably be regarded as device related should be reported to Alcon Laboratories, Inc.:

By Phone:  
In USA - (800) 757-9780  
Website:

<http://www.alcon.com/contact-us/>

Each IOL is identified by a serial number which provides traceability, and this information should be given to Alcon.

**Clareon™ Toric Aspheric Hydrophobic Acrylic IOL  
w/ the AutonoMe™ Automated Pre-loaded Delivery System  
Model: CNA0T3-CNA0T9**

NOTE: Text appearing in gray is for information purposes only.

---

**EXPIRATION DATE**

Sterility is guaranteed unless the pouch is damaged or opened. The expiration date is clearly indicated on the outside of the lens package. Any lens held after the expiration date should be returned to Alcon Laboratories, Inc. (see RETURNED GOODS POLICY).

**RETURNED GOODS POLICY**

Returned lenses will only be accepted in exchange for other products, not credit. All returns must be accompanied by an Alcon Laboratories, Inc. Returned Goods Number and should be shipped via traceable means. A Returned Goods Number is obtained by contacting Alcon Laboratories, Inc. Customer Service Department. Issuance of this number does not constitute final acceptance of the returned products. For detailed policy guidelines including exchange, please contact your Sales or Customer Service Representative.

**Clareon™ Toric Aspheric Hydrophobic Acrylic IOL  
w/ the AutonoMe™ Automated Pre-loaded Delivery System  
Model: CNA0T3-CNA0T9**

NOTE: Text appearing in gray is for information purposes only.

**CLINICAL STUDIES**

Three prospective clinical studies with other Alcon IOLs were performed that support the safety and effectiveness of the Clareon™ Toric IOL (Models CNA0T3-CNA0T9) and are described in this labeling: †

1. Data from the US study of Clareon™ IOL demonstrate favorable visual acuity and adverse event outcomes of the Clareon™ IOL. IOL rotational stability of the Clareon™ IOL was also assessed and are shown below to support Clareon™ Toric IOL along with safety data to support the Clareon™ material.
2. AcrySof™ Toric IOL (Models SA60T3-SA60T5) clinical study data are presented to describe the safety and effectiveness of the toric optical design of the Clareon™ Toric IOL.
3. AcrySof™ Toric High Cylinder Power IOL (Models SA60T8 and SA60T9) clinical study data are presented to describe the safety and effectiveness of the high cylinder toric optical design of the Clareon™ Toric IOL.

Summaries of these clinical studies are provided below to describe the performance characteristics of the Clareon™ Toric IOL. Please use caution when comparing these results with results from similar device studies due to potential differences in patient cohorts, test methods, etc.

†NOTE: Data from clinical studies with other Alcon IOLs (i.e., AcrySof™ Toric IOL and Clareon™ IOL) support the safety and effectiveness of the Clareon™ Toric IOL (Models CNA0T3-CNA0T9).

- The aspheric feature, which is also on the anterior side of the Clareon™ Toric IOL, is identical to the clinically studied Clareon™ IOL.
- The toric feature, which is also on the posterior side of the Clareon™ Toric IOL, is identical to the clinically studied AcrySof™ Toric IOL.
- The Clareon™ material will not affect the performance of the toric or aspheric features as the mechanical design, optical design, and optical performance specifications are maintained between the Clareon™ Toric IOL and AcrySof™ Toric IOL.

**1. STUDY RESULTS FOR Clareon™ ASPHERIC HYDROPHOBIC ACRYLIC IOL**

A prospective, multicenter, open-label clinical study in adult subjects requiring cataract surgery with IOL implantation was performed on the Clareon™ IOL in the United States. The objective of this study was to demonstrate favorable visual acuity and adverse event outcomes for the Clareon™ IOL compared to historical safety and performance endpoint (SPE) rates as reported in EN ISO 11979-7:2014. The results achieved by the subjects successfully followed for 12 Months postoperatively (defined as 330 to 420 days postoperative) provide reasonable assurance that the Clareon™ IOL is a safe and effective device for the visual correction of aphakia following cataract surgery. The subject population in the clinical study consisted of 350 subjects in need of cataract surgery that were unilaterally implanted, the percentage of females (60.9%) exceeded the percentage of males (39.1%) enrolled. The mean age for the total population was 69.7 years.

Visual Acuity

The best corrected distance visual acuity (BCDVA) achieved at one year postoperatively by the Best Case Analysis Set is presented in **Table 7** and visual acuity achieved by All-Implanted Analysis Set is presented in **Table 8**. Similar data for BCDVA expressed as Snellen values are presented in **Tables 9 and 10**. The Best Case analysis included all eyes successfully implanted with the test article, had at least one postoperative visit, did not have any ocular pathology at Visit 0 (preoperative), had no macular degeneration at any visit, and did not have any previous surgery for the correction of refractive errors. All-Implanted Analysis set includes all eyes with successful test article implantation.

The one-sided exact 95% upper confidence limit for the percentage of subjects with monocular BCDVA of 0.3 logMAR or better at 12 months postoperative (Visit 5) is greater than or equal to the SPE rates as reported in EN ISO 11979-7:2014.

The uncorrected distance visual acuity (UCDVA) at one year postoperatively is presented in **Table 11** for the Best Case Analysis, and UCDVA achieved by All-Implanted Analysis Set is presented in **Table 12**.

**Table 7: Best Corrected Visual Acuity in the Best Case Analysis Set at Month 12, Clareon™ IOL**

<b>Visual Acuity</b>	<b>n</b>	<b>%</b>
0.0 logMAR or better	271	83.1
0.1 logMAR or better	307	94.2
0.2 logMAR or better	323	99.1
0.3 logMAR or better	325	99.7

**Clareon™ Toric Aspheric Hydrophobic Acrylic IOL  
w/ the AutoMe™ Automated Pre-loaded Delivery System  
Model: CNA0T3-CNA0T9**

NOTE: Text appearing in gray is for information purposes only.

Worse than 0.3 logMAR	1	0.3
ISO SPE Rate for % of 0.3 logMAR or better	96.7%	
N	326	
ISO SPE Rate = BS EN ISO 11979-7:2014, Ophthalmic Implants - Intraocular Lenses - Part 7: Clinical Investigations, Table B.4 - Posterior Chamber IOL Adverse Event Safety and Performance Endpoint Rates		

**Table 8: Best Corrected Visual Acuity in the All-Implanted Analysis Set at Month 12, Clareon™ IOL**

<b>Visual Acuity</b>	<b>n</b>	<b>%</b>
0.0 logMAR or better	277	81.0
0.1 logMAR or better	318	93.0
0.2 logMAR or better	339	99.1
0.3 logMAR or better	341	99.7
Worse than 0.3 logMAR	1	0.3
ISO SPE Rate for % of 0.3 logMAR or better	92.5%	
N	342	
ISO SPE Rate = BS EN ISO 11979-7:2014, Ophthalmic Implants - Intraocular Lenses - Part 7: Clinical Investigations, Table B.3 - Posterior Chamber IOL Adverse Event Safety and Performance Endpoint Rates		

**Table 9: Best Corrected Visual Acuity in the Best Case Analysis Set at Month 12 (Snellen), Clareon™ IOL**

<b>Visual Acuity</b>	<b>n</b>	<b>%</b>
20/20 or better	287	88.0
20/25 or better	316	96.9
20/32 or better	324	99.4
20/40 or better	325	99.7
Worse than 20/40	1	0.3
N	326	
Note: 20/20 = 0.04 logMAR      20/25 = 0.14 logMAR      20/32 = 0.24 logMAR 20/40 = 0.34 logMAR		

**Clareon™ Toric Aspheric Hydrophobic Acrylic IOL  
w/ the AutoMe™ Automated Pre-loaded Delivery System  
Model: CNA0T3-CNA0T9**

NOTE: Text appearing in gray is for information purposes only.

**Table 10: Best Corrected Visual Acuity in the All-Implanted Analysis Set at Month 12 (Snellen), Clareon™ IOL**

Visual Acuity	n	%
20/20 or better	297	86.8
20/25 or better	331	96.8
20/32 or better	340	99.4
20/40 or better	341	99.7
Worse than 20/40	1	0.3
N	342	
Note: 20/20 = 0.04 logMAR      20/25 = 0.14 logMAR      20/32 = 0.24 logMAR 20/40 = 0.34 logMAR		

**Table 11: Uncorrected Visual Acuity in the Best Case Analysis Set at Month 12, Clareon™ IOL**

Statistic	(N = 334)
n	326
Mean (SD)	0.042 (0.1348)
Median	-0.02
(Min, Max)	(-0.20, 0.70)
95% CI	(-0.027, -0.056)

**Table 12: Uncorrected Visual Acuity in the All-Implanted Analysis Set at Month 12, Clareon™ IOL**

Statistic	(N = 350)
n	342
Mean (SD)	0.043 (0.1339)
Median	0.02
(Min, Max)	(-0.20, 0.70)
95% CI	(0.029, 0.057)

**IOL Rotation**

The rotational stability of the Clareon™ IOL was evaluated in a subset of the total study population, which included 141 subjects at 6 sites. Results were compared to performance targets in EN ISO 11979-7:2014, defined as the difference between IOL axis orientation on day of surgery and at the Month 6 visit. A total of 98.4% of subjects had IOL rotation <10 degrees and 99.2% had rotation <20 degrees or <30 degrees at Month 6 compared to the day of surgery, which met the pre-specified performance targets. Results shown in **Table 13**.

**Table 13: Categorical Statistics for Absolute IOL Rotation (10 Degrees Increment) at Month 6 from Day of Surgery, Rotation Analysis Set, Clareon™ IOL**

Category	(N=141)	
	n	%
Total	124	-
Less than 10 degrees	122	98.4
Less than 20 degrees	123	99.2
Less than 30 degrees	123	99.2
Greater than 30 degrees	1	0.8
N = Number of eyes in the analysis set n = Number of eyes in specified category Total = Number of eyes with data Percentages are calculated as (n/Total) * 100		

In an additional analysis between Month 1 and Month 6, 98.4% of subjects implanted with the Clareon™ IOL had an absolute rotation of less than or equal to 5 degrees. The remaining subjects (1.6%) had rotation between 5 to 10 degrees.

**Clareon™ Toric Aspheric Hydrophobic Acrylic IOL  
w/ the AutonoMe™ Automated Pre-loaded Delivery System  
Model: CNA0T3-CNA0T9**

NOTE: Text appearing in gray is for information purposes only.

Absolute rotation of Clareon™ IOL were also described at all post-operative visits (1 Day, 1 Week, 1 Month, and 6 Months) compared to the day of surgery. Descriptive statistics results at each postoperative visit are shown in **Table 14**.

**Table 14: Descriptive Statistics for Absolute IOL Rotation (Degrees), Rotation Analysis Set, Clareon™ IOL**

Visit	Statistic	(N = 141)*
1 Day	n	127
	Mean (SD)	1.8483 (3.72254)
	Median	0.942
	(Min, Max)	(0.002, 38.232)
	95% CI	(1.1946, 2.5020)
1 Week	n	126
	Mean (SD)	1.9942 (3.86948)
	Median	1.213
	(Min, Max)	(0.020, 40.547)
	95% CI	(1.3119, 2.6764)
1 Month	n	127
	Mean (SD)	2.2335 (3.95863)
	Median	1.414
	(Min, Max)	(0.008, 41.110)
	95% CI	(1.5384, 2.9287)
6 Months	n	124
	Mean (SD)	2.2696 (3.87231)
	Median	1.449
	(Min, Max)	(0.014, 40.033)
	95% CI	(1.5812, 2.9579)
N = Number of eyes in the analysis set n = Number of eyes at visit with data SD = Standard Deviation, CI = Confidence Interval * Of 141, 10 had images at baseline which were not readable and at each visit, individual subjects may have had images which were missing or not readable		

**Adverse Events**

The cumulative and persistent adverse events rates for the Safety Analysis Set are presented in **Table 15**. Cumulative adverse events are those that occur at any point in the study while persistent adverse events are those that occur or are ongoing at the 12 Month Visit. The Safety Analysis Set included all eyes with attempted implantation with the test article (successful or aborted after contact with the eye). In this study, the number of eyes in the Safety Analysis Set was equivalent to the All-Implanted Analysis Set.

For both cumulative and persistent adverse events, the exact one-sided 95% lower confidence limit of cumulative and persistent adverse events were within limits compared to the SPE rates reported in EN ISO 11979-7:2014.

**Clareon™ Toric Aspheric Hydrophobic Acrylic IOL  
w/ the AutoMe™ Automated Pre-loaded Delivery System  
Model: CNA0T3-CNA0T9**

NOTE: Text appearing in gray is for information purposes only.

**Table 15: Cumulative and Persistent Adverse Events in the Safety Analysis Set, Clareon™ IOL**

	(N = 350)			
	n (%)	2-sided 95% CI	1-sided 95% Lower CL	SPE %
<b>Cumulative Serious Adverse Events</b>				
Cystoid macular oedema	3 (0.9)	(0.18, 2.48)	0.23	3.0
Hypopyon	0 (0.0)	(0.00, 1.05)	0.00	0.3
Endophthalmitis	0 (0.0)	(0.00, 1.05)	0.00	0.1
Lens dislocated from posterior chamber	0 (0.0)	(0.00, 1.05)	0.00	0.1
Pupillary block	0 (0.0)	(0.00, 1.05)	0.00	0.1
Retinal detachment	0 (0.0)	(0.00, 1.05)	0.00	0.3
Secondary surgical intervention*	6 (1.7)	(0.63, 3.69)	0.75	0.8
<b>Other</b>				
Herpes virus infection	1 (0.3)	(0.01, 1.58)	0.01	NA
Macular fibrosis	1 (0.3)	(0.01, 1.58)	0.01	NA
Macular hole	1 (0.3)	(0.01, 1.58)	0.01	NA
Punctate keratitis	1 (0.3)	(0.01, 1.58)	0.01	NA
Retinal tear	2 (0.6)	(0.07, 2.05)	0.10	NA
<b>Persistent Serious Adverse Events</b>				
Corneal stroma oedema	0 (0.0)	(0.00, 1.05)	0.00	0.3
Cystoid macular oedema	1 (0.3)	(0.01, 1.58)	0.01	0.5
Iritis	0 (0.0)	(0.00, 1.05)	0.00	0.3
Raised IOP requiring treatment	0 (0.0)	(0.00, 1.05)	0.00	0.4
CI = Confidence Interval CL = Confidence Limit SPE = Safety and Performance Endpoint Persistent = Present or ongoing at the final scheduled visit IOP = Intraocular Pressure SPE rates are from BS EN ISO 11979-7:2014, Ophthalmic Implants - Intraocular Lenses - Part 7: Clinical Investigations, Table B.2 - Posterior Chamber IOL Adverse Event Safety and Performance Endpoint Rates If an eye has multiple occurrences of an AE, the eye is presented only once in the respective eye count column (n) for the corresponding AE. "Other" includes the MedDRA Preferred Term for ocular SAEs that do not belong to any predefined SPE categories. Percentages are calculated as (n/N) * 100. The SPE rate is considered not exceeded if the 1-sided 95% lower CL for an AE is less than the SPE%. *None of these secondary surgical interventions were related to the IOL.				

**IOL Observations**

At all five scheduled postoperative visits and at unscheduled visits, slit-lamp examinations were performed. The list of pre-specified slit-lamp findings included IOL observations, which were described as IOL glistenings, scratches/cracks on the IOL, and surface haze on the IOL. Across 1,852 postoperative (including unscheduled) visits, no IOL observations (IOL glistenings, scratches/cracks on the IOL, and surface haze on the IOL) were noted for the Clareon™ IOL.

**2. AcrySof™ TORIC INTRAOCULAR LENS CLINICAL STUDY**

Bench studies have demonstrated equivalent optical performance between the AcrySof™ Toric IOL and the Clareon™ Toric IOL. Accordingly, the data presented in this section and the data presented in the section on AcrySof™ Toric Posterior Chamber High Cylinder Power IOLs are applicable to both AcrySof™ and Clareon™ Toric IOLs.

**Overview of Clinical Study**

A multicenter, subject-masked, randomized, prospective clinical study was performed in the United States to evaluate the safety and effectiveness of AcrySof™ Toric IOL (Models SA60T3-SA60T5), collectively referred to as SA60TT) compared to Model SA60AT as control lens when implanted into the capsular bag following

**Clareon™ Toric Aspheric Hydrophobic Acrylic IOL  
w/ the AutonoMe™ Automated Pre-loaded Delivery System  
Model: CNA0T3-CNA0T9**

NOTE: Text appearing in gray is for information purposes only.

---

phacoemulsification. In this study, the results achieved by the subjects successfully followed for 6 months postoperatively (defined as 120 to 180 days postoperative after the second eye implant) provide reasonable assurance that the AcrySof™ Toric IOL is a safe and effective device for the visual correction of aphakia and pre-existing corneal astigmatism following cataract surgery.

Only data from the first operative eye from those subjects who received either a Model SA60TT or Model SA60AT intraocular lens are included. Three different lens models of varying cylinder correction were evaluated in this clinical study. The three different models evaluated and their applicable cylinder powers are listed in **Table 16**.



**Clareon™ Toric Aspheric Hydrophobic Acrylic IOL  
w/ the AutonoMe™ Automated Pre-loaded Delivery System  
Model: CNA0T3-CNA0T9**

NOTE: Text appearing in gray is for information purposes only.

**Table 16: AcrySof™ Toric IOL: IOL Models and Cylinder Power in Clinical Study**

IOL Model**	Cylinder Power		Recommended Corneal Astigmatism Correction Ranges
	at IOL plane	at corneal plane	
SA60T3	1.50	1.03	0.75 - 1.50 D
SA60T4	2.25	1.55	1.50 - 2.00 D
SA60T5	3.00	2.06	2.00 D & up

\*\*These IOL models are collectively referred to as SA60TT in the text that follows.

The recommended corneal astigmatism correction ranges are based on 1) the preoperative corneal astigmatism and 2) the predicted effect of 0.5 diopter surgically induced astigmatism for a standardized temporal incision. The combination of these two parameters is used in Alcon provided software to select the appropriate Toric IOL model and recommended axis of placement. As such, the recommended range of corneal astigmatism to be corrected while not identical, is directly related to, the preoperative keratometric cylinder.

**Subject Population**

Specific requirements for study participation included (1)  $\geq 0.75$  D of preoperative With-the-Rule or preoperative oblique regular corneal astigmatism and (2)  $\geq 1.00$  D of preoperative Against-the-Rule regular corneal astigmatism. The subject population implanted with a Model SA60TT in the first operative eye consists of 53.3% females and 46.7% males. The subject population implanted with the Model SA60AT (control) intraocular lens consists of 57.2% females and 42.8% males. Stratifying by race for the Model SA60TT population, 97.6% are Caucasian, 2.0% are Black, and 0.4% are other. The control (SA60AT) population is 95.6% Caucasian, 1.6% Black, 1.2% Asian and 1.6% other. The mean age for the population receiving the Model SA60TT and SA60AT were 70.0 and 72.4, respectively.

**Uncorrected Distance Visual Acuity (UCDVA)**

A summary of uncorrected distance visual acuity achieved for Models SA60TT and SA60AT at six months postoperatively (Form 5 visit) is presented in **Table 17**.

**Table 17: Uncorrected Distance Visual Acuity, Status at Form 5  
Lens Models SA60TT and SA60AT, All Implanted**

	Sample size	Acuity										20/40 or better	
		20/20 or better		20/25		20/32		20/40		Worse than 20/40			
	N	n	%	n	%	n	%	n	%	n	%	n	%
Total (SA60TT)	211	81	38.4	59	28.0	36	17.1	22	10.4	13	6.2	198	93.8
Total (SA60AT)	210	40	19.0	46	21.9	37	17.6	39	18.6	48	22.9	162	77.1

At six months postoperatively (Form 5 visit), shown in **Figure 10**, 93.8% of Model SA60TT subjects achieved 20/40 or better UCDVA (first operative eye of the All Implanted data set) compared to 77.1% of the subjects implanted with the control Model SA60AT. The difference in UCDVA between Models SA60TT and SA60AT was statistically significant (all p-values  $\leq 0.0001$ ) in favor of Model SA60TT.

**Clareon™ Toric Aspheric Hydrophobic Acrylic IOL  
w/ the AutonoMe™ Automated Pre-loaded Delivery System  
Model: CNA0T3-CNA0T9**

NOTE: Text appearing in gray is for information purposes only.

**Figure 10: Cumulative UCDVA, Status at Form 5, Model SA60TT vs. Control**

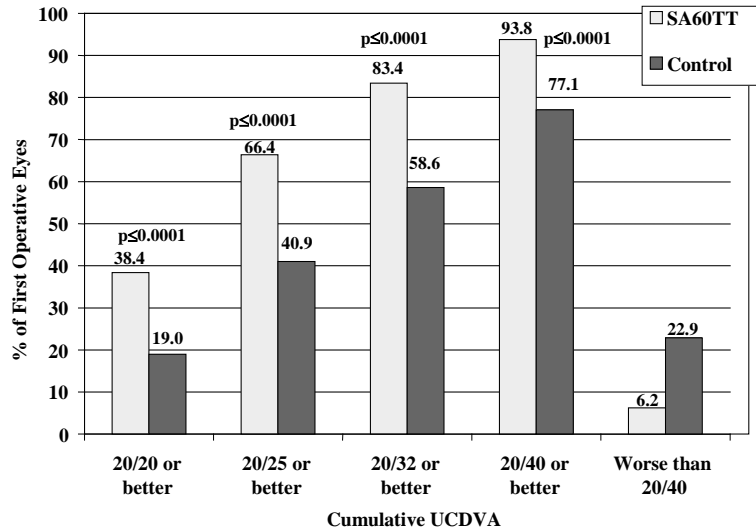

Similar results were noted when data was analyzed by cylinder range:

- The difference in cumulative UCDVA between Models SA60T3 and SA60AT was statistically significant (all p-values ≤ 0.0115) for each visual acuity category (20/20 or better, 20/25 or better, 20/32 or better and 20/40 or better) in favor of Model SA60T3.
- The difference in cumulative UCDVA between Models SA60T4 and SA60AT was statistically significant (all p-values ≤ 0.0082) for each visual acuity category (20/25 or better, 20/32 or better and 20/40 or better) in favor of Model SA60T4, with the exception of the 20/20 or better category.
- The difference in cumulative UCDVA between Models SA60T5 and SA60AT was statistically significant (all p-values ≤ 0.0171) for each visual acuity category (20/20 or better, 20/25 or better, 20/32 or better and 20/40 or better) in favor of Model SA60T5.

**Best Spectacle Distance Corrected Visual Acuity (BSCDVA)**

A summary of best spectacle corrected distance visual acuity (BSCDVA) achieved at six months postoperatively (Form 5 visit) among subjects who did not have any visually significant preoperative pathology or macular degeneration at any time (Best Case) is presented in **Table 18A**. Visual acuity achieved by the overall subject population is shown in **Table 18C**. Control data are found for the same data sets in Tables **18B** and **18D**, respectively.

Of the first operative eyes implanted with a Model SA60TT and examined at six months postoperatively (Form 5 visit), 100.0% achieved a BSCDVA of 20/40 or better in the Best Case dataset. These rates exceed the FDA grid rates of 96.7%.

**Table 18A: BSCDVA by Age Category, Status at Form 5 - Lens Model SA60TT, Best Case**

Age Category	Sample size N	Acuity										20/40 or better	
		20/20 or better		20/25		20/32		20/40		Worse than 20/40			
		n	%	n	%	n	%	n	%	n	%	n	%
<60	29	27	93.1	1	3.4	1	3.4	0	0	0	0	29	100.0
60-69	51	42	82.4	7	13.7	2	3.9	0	0	0	0	51	100.0
70-79	73	57	78.1	13	17.8	3	4.1	0	0	0	0	73	100.0
≥80	20	14	70.0	4	20.0	1	5.0	1	5.0	0	0	20	100.0
Total	173	140	80.9	25	14.5	7	4.0	1	0.6	0	0	173	100.0

**Clareon™ Toric Aspheric Hydrophobic Acrylic IOL  
w/ the AutonoMe™ Automated Pre-loaded Delivery System  
Model: CNA0T3-CNA0T9**

NOTE: Text appearing in gray is for information purposes only.

**Table 18B: BSCDVA by Age Category, Status at Form 5 - Lens Model SA60AT, Best Case**

Age Category	Sample size	Acuity										20/40 or better	
		20/20 or better		20/25		20/32		20/40		Worse than 20/40			
		N	n	%	n	%	n	%	n	%	n	%	n
<60	15	13	86.7	1	6.7	1	6.7	0	0	0	0	15	100.0
60-69	49	38	77.6	11	22.4	0	0	0	0	0	0	49	100.0
70-79	75	48	64.0	21	28.0	6	8.0	0	0	0	0	75	100.0
≥80	32	19	59.4	8	25.0	2	6.3	3	9.4	0	0	32	100.0
Total	171	118	69.0	41	24.0	9	5.3	3	1.8	0	0	171	100.0

Of the first operative eyes implanted with a Model SA60TT and examined at six months postoperatively (Form 5 visit), 100.0% achieved a BSCDVA of 20/40 or better in the All Implanted dataset. These rates exceed the FDA grid rates of 92.5%.

**Table 18C: BSCDVA by Age Category, Status at Form 5 - Lens Model SA60TT, All Implanted**

Age Category	Sample size	Acuity										20/40 or better	
		20/20 or better		20/25		20/32		20/40		Worse than 20/40			
		N	n	%	n	%	n	%	n	%	n	%	n
<60	33	30	90.9	2	6.1	1	3.0	0	0	0	0	33	100.0
60-69	56	47	83.9	7	12.5	2	3.6	0	0	0	0	56	100.0
70-79	90	72	80.0	15	16.7	3	3.3	0	0	0	0	90	100.0
≥80	32	22	68.8	5	15.6	4	12.5	1	3.1	0	0	32	100.0
Total	211	171	81.0	29	13.7	10	4.7	1	0.5	0	0	211	100.0

**Table 18D: BSCDVA by Age Category, Status at Form 5 - Lens Model SA60AT, All Implanted**

Age Category	Sample size	Acuity										20/40 or better	
		20/20 or better		20/25		20/32		20/40		Worse than 20/40			
		N	n	%	n	%	n	%	n	%	n	%	n
<60	15	13	86.7	1	6.7	1	6.7	0	0	0	0	15	100.0
60-69	54	41	75.9	12	22.2	1	1.9	0	0	0	0	54	100.0
70-79	91	59	64.8	22	24.2	10	11.0	0	0	0	0	91	100.0
≥80	49	28	57.1	13	26.5	2	4.1	3	6.1	3	6.1	46	93.9
Total	209	141	67.5	48	23.0	14	6.7	3	1.4	3	1.4	206	98.6

Figures 11A–11C show a summary of cumulative best corrected visual acuities for each Toric model compared to the control subjects in the same cylinder range for the All Implanted dataset.

**Clareon™ Toric Aspheric Hydrophobic Acrylic IOL  
w/ the AutoMe™ Automated Pre-loaded Delivery System  
Model: CNA0T3-CNA0T9**

NOTE: Text appearing in gray is for information purposes only.

**Figure 11A: Cumulative BSCDVA, Model SA60T3 vs. Control, Form 5, All Implanted**

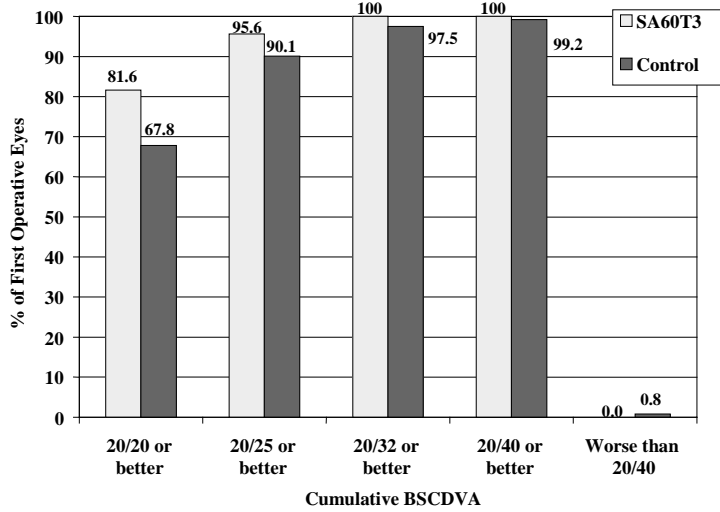

**Figure 11B: Cumulative BSCDVA, Model SA60T4 vs. Control, Form 5, All Implanted**

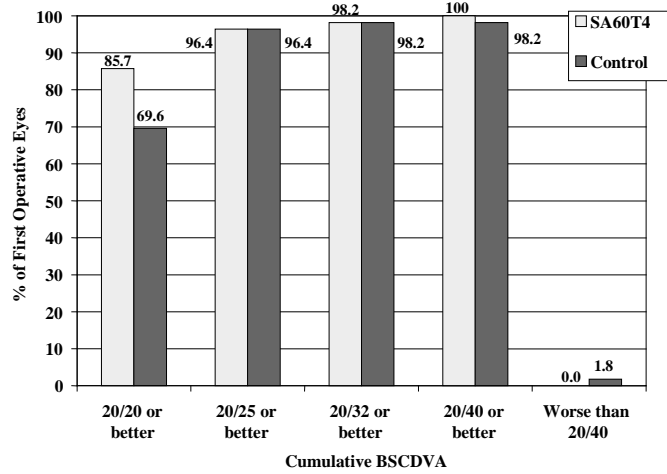

**Figure 11C: Cumulative BSCDVA, Model SA60T5 vs. Control, Form 5, All Implanted**

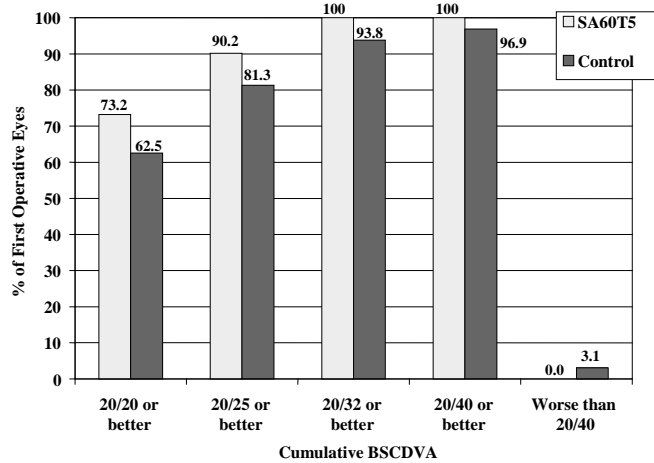

**Clareon™ Toric Aspheric Hydrophobic Acrylic IOL  
w/ the AutoMe™ Automated Pre-loaded Delivery System  
Model: CNA0T3-CNA0T9**

NOTE: Text appearing in gray is for information purposes only.

**Absolute Residual Refractive Cylinder**

**Figures 12A-12C** demonstrate that residual refractive cylinder values were statistically significantly lower among those subjects implanted with an AcrySof™ Toric IOL Model SA60T3, SA60T4, or SA60T5 when compared to the corresponding subjects implanted with the control Model SA60AT. Subjects implanted with an AcrySof™ Toric Model SA60T3 showed a 62.4% mean reduction in refractive cylinder from the preoperative visit (keratometric cylinder) as compared to the 10.8% mean reduction for subjects implanted with the concurrent control Model SA60AT. Subjects implanted with an AcrySof™ Toric IOL Model SA60T4 or SA60T5 showed similar results with a mean reduction in refractive cylinder of 54.8 % and 67.8%, respectively, as compared to subjects implanted with the concurrent control model who had a mean reduction in refractive cylinder of 22.1% and 27.7%, respectively. Each of the AcrySof™ Toric Lens Models SA60T3, SA60T4 and SA60T5 had at least a 3-fold increase in the likelihood of achieving residual refractive cylinder of 0.5 D or less as compared to the corresponding control model.

**Figure 12A: AcrySof™ Toric IOL: Absolute Residual Refractive Cylinder, Model SA60T3 vs. Control, 6 Month Visit (Form 5), All Implanted**

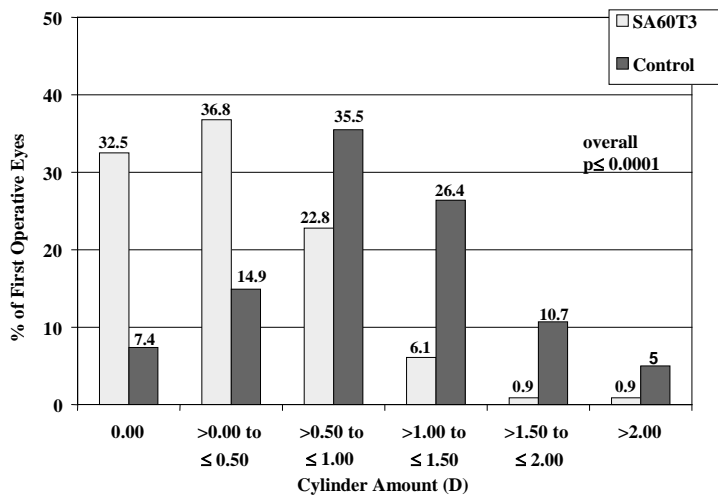

**Figure 12B: AcrySof™ Toric IOL: Absolute Residual Refractive Cylinder, Model SA60T4 vs. Control, 6 Month Visit (Form 5), All Implanted**

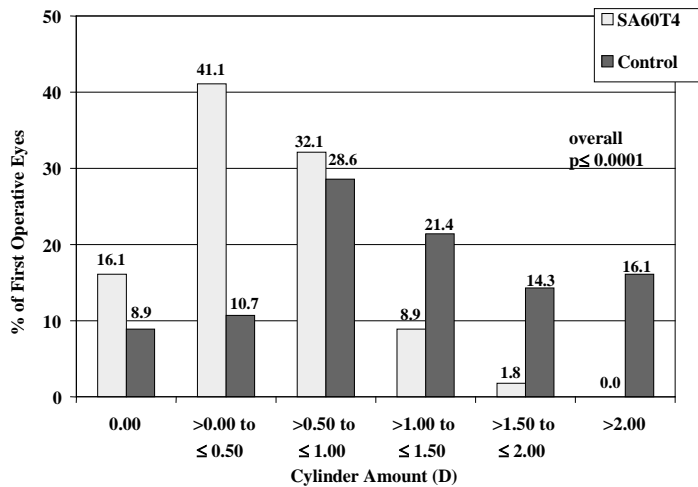

**Clareon™ Toric Aspheric Hydrophobic Acrylic IOL  
w/ the AutoMe™ Automated Pre-loaded Delivery System  
Model: CNA0T3-CNA0T9**

NOTE: Text appearing in gray is for information purposes only.

**Figure 12C: AcrySof™ Toric IOL: Absolute Residual Refractive Cylinder, Model SA60T5 vs. Control, 6 Month Visit (Form 5), All Implanted**

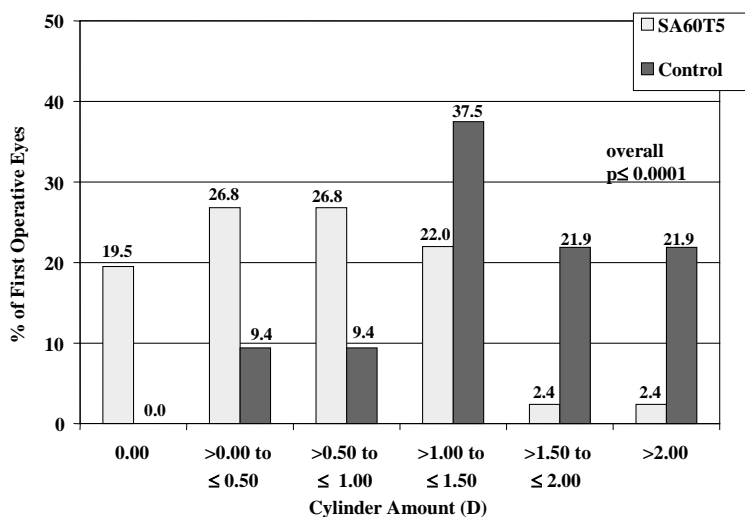

**Stability of Cylinder**

Subjects implanted with lens Model SA60TT exhibited stability of cylinder at Form 4 (3 months) with greater than 90% of all subjects changing less than or equal to 1.00 diopter at consecutive visits between Form 3 (one month) and Form 6 (twelve months) as described in **Tables 19A-19D**.

**Table 19A: AcrySof™ Toric IOL: Stability of Cylinder  
(Eyes that had 2 consecutive exams, but not necessarily every follow-up exam)**

Recommended Corneal Astigmatism Correction Ranges	Toric IOL Model	Magnitude of Vector Change in Cylinder	1 and 3 Months n/N,%	3 and 6 Months n/N,%	6 and 12 Months n/N,%
< 1.5 D	SA60T3	≤ 1.00 D	106/107,99.07%	101/105,96.19%	55/55,100.00%
		Mean Change	0.28	0.29	0.20
		SD	0.32	0.33	0.25
≥ 1.5 - < 2.0 D	SA60T4	≤ 1.00 D	54/56,96.43%	53/54,98.15%	25/27,92.59%
		Mean Change	0.40	0.27	0.46
		SD	0.35	0.22	0.45
≥ 2.0 D	SA60T5	≤ 1.00 D	40/45,88.89%	35/40,87.50%	27/30,90.00%
		Mean Change	0.43	0.42	0.41
		SD	0.44	0.45	0.38
Combined	SA60TT	≤ 1.00 D	200/208,96.15% (93.54,98.77)	189/199,94.97% (91.94,98.01)	107/112,95.54% (91.71,99.36)
		Mean Change	0.35	0.31	0.32
		SD	0.36	0.34	0.36
		95% CI	0.30,0.39	0.26,0.36	0.25,0.39

n/N,%,(%CI) are for percent with change between ± 1.00D

**Clareon™ Toric Aspheric Hydrophobic Acrylic IOL  
w/ the AutoMe™ Automated Pre-loaded Delivery System  
Model: CNA0T3-CNA0T9**

NOTE: Text appearing in gray is for information purposes only.

**Table 19B: AcrySof™ Toric IOL: Stability of Cylinder  
(Eyes that had every follow-up exam up to Form 6, 12 months)**

Recommended Corneal Astigmatism Correction Ranges	Toric IOL Model	Magnitude of Vector Change in Cylinder	1 and 3 Months n/N,%	3 and 6 Months n/N,%	6 and 12 Months n/N,%
< 1.5 D	SA60T3	≤ 1.00 D	34/34,100.00%	34/34,100.00%	34/34,100.00%
		Mean Change	0.25	0.24	0.21
		SD	0.23	0.22	0.24
≥ 1.5 - < 2.0 D	SA60T4	≤ 1.00 D	17/17,100.00%	16/17,94.12%	16/17,94.12%
		Mean Change	0.27	0.25	0.35
		SD	0.25	0.26	0.33
≥ 2.0 D	SA60T5	≤ 1.00 D	17/19,89.47%	15/19,78.95%	16/19,84.21%
		Mean Change	0.44	0.56	0.52
		SD	0.47	0.50	0.43
Combined	SA60TT	≤ 1.00 D	68/70,97.14% (93.23,100.00)	65/70,92.86% (86.82,98.90)	66/70,94.29% (88.84,99.73)
		Mean Change	0.31	0.33	0.33
		SD	0.32	0.35	0.34
		95% CI	0.23,0.38	0.24,0.41	0.25,0.41

n/N,%,(%CI) are for percent with change between ± 1.00D

**Table 19C: AcrySof™ Toric IOL: Stability of Absolute Cylinder  
(Eyes that had 2 consecutive exams, but not necessarily every follow-up exam)**

Recommended Corneal Astigmatism Correction Ranges	Toric IOL Model	Magnitude of Change in Absolute Cylinder	1 and 3 Months n/N,%	3 and 6 Months n/N,%	6 and 12 Months n/N,%
< 1.5 D	SA60T3	≤ 1.00 D	107/107,100.00%	104/105,99.05%	55/55,100.00%
		Mean Change	0.04	0.02	0.05
		SD	0.32	0.38	0.29
≥ 1.5 - < 2.0 D	SA60T4	≤ 1.00 D	54/56,96.43%	54/54,100.00%	27/27,100.00%
		Mean Change	0.18	0.05	-0.12
		SD	0.42	0.27	0.41
≥ 2.0 D	SA60T5	≤ 1.00 D	44/45,97.78%	37/40,92.50%	29/30,96.67%
		Mean Change	0.09	0.06	0.00
		SD	0.38	0.49	0.45
Combined	SA60TT	≤ 1.00 D	205/208,98.56% (96.93,100.00)	195/199,97.99% (96.04,99.94)	111/112,99.11% (97.36,100.00)
		Mean Change	0.09	0.03	-0.01
		SD	0.37	0.38	0.37
		95% CI	0.04,0.14	-0.02,0.09	-0.08,0.06

n/N,%,(%CI) are for percent with change between ± 1.00D

**Clareon™ Toric Aspheric Hydrophobic Acrylic IOL  
w/ the AutonoMe™ Automated Pre-loaded Delivery System  
Model: CNA0T3-CNA0T9**

NOTE: Text appearing in gray is for information purposes only.

**Table 19D: AcrySof™ Toric IOL: Stability of Absolute Cylinder  
(Eyes that had every follow-up exam up to Form 6, 12 months)**

Recommended Corneal Astigmatism Correction Ranges	Toric IOL Model	Magnitude of Change in Absolute Cylinder	1 and 3 Months n/N,%	3 and 6 Months n/N,%	6 and 12 Months n/N,%
< 1.5 D	SA60T3	≤ 1.00 D	34/34,100.00%	34/34,100.00%	34/34,100.00%
		Mean Change	0.01	-0.01	0.07
		SD	0.28	0.31	0.28
≥ 1.5 - < 2.0 D	SA60T4	≤ 1.00 D	17/17,100.00%	17/17,100.00%	17/17,100.00%
		Mean Change	0.06	0.19	-0.04
		SD	0.30	0.21	0.42
≥ 2.0 D	SA60T5	≤ 1.00 D	18/19,94.74%	17/19,89.47%	18/19,94.74%
		Mean Change	0.17	0.05	0.01
		SD	0.45	0.54	0.55
Combined	SA60TT	≤ 1.00 D	69/70,98.57% (95.78,100.00)	68/70,97.14% (93.23,100.00)	69/70,98.57% (95.78,100.00)
		Mean Change	0.07	0.05	0.03
		SD	0.34	0.38	0.40
		95% CI	-0.01,0.15	-0.04,0.14	-0.07,0.12

n/N,%,(%CI) are for percent with change between ± 1.00D

**Adverse Events**

The incidence of cumulative adverse events for the Model SA60TT compared favorably to the FDA historical grid rates. Only the rates for retinal detachment/repair and surgical reintervention exceeded the FDA historical grid (**Table 20**). However, neither of these rates were statistically significant (p=0.5196 and p=0.1336, respectively). No occurrences of persistent adverse events were observed in any subjects implanted with the AcrySof™ Toric IOL.

**Table 204: AcrySof™ Toric IOL: Adverse Events Incidence Rates, First Eye – Safety**

	Model SA60TT N=244		FDA Grid Rate
Cumulative Adverse Events	N	%	%
Retinal Detachment/Repair	1	0.4	0.3
Surgical Reintervention	4**	1.6	0.8
IOL Reposition Due to Rotation	1	0.4	NA
IOL Replacement Due to Rotation	1	0.4	NA
Laser Treatment	2	0.8	NA
Paracentesis	1	0.4	NA

The incidence rates in this table are based upon the number of eyes with an event divided by the number of eyes implanted.

Cumulative adverse events are those events that have occurred at any time during the clinical study.

FDA Grid Rate = FDA Grid of Adverse Events with Posterior Chamber Intraocular Lens Historical Controls, FDA Intraocular Lens Guidance Document, Annex B (October 14, 1999)

\*\*There were 5 occurrences of surgical reintervention in 4 eyes for Model SA60TT first eye

The incidence of cumulative adverse events for the Model SA60TT also compared favorably to the concurrent control.

**Distance-Vision Spectacle Independence**

Spectacle independence was assessed in the study by direct subject responses obtained from a self-reported, binocular subject questionnaire. Since the AcrySof™ Toric IOL study was completed in 2005, the questionnaire utilized was not developed using the US FDA guidance document "*Patient-Reported Outcomes Measures: Use in Medical Product Development to Support Labeling Claims*" dated December 2009.

Statistically significantly more Model SA60TT subjects reported postoperative distance-vision spectacle independence compared to Model SA60AT subjects (59.9% versus 37.7%, respectively) when unilaterally implanted. Distance-vision



**Clareon™ Toric Aspheric Hydrophobic Acrylic IOL  
w/ the AutoMe™ Automated Pre-loaded Delivery System  
Model: CNA0T3-CNA0T9**

NOTE: Text appearing in gray is for information purposes only.

spectacle independence was defined as the percentage of subjects who selected the “none of the time” response for distance-vision frequency-of-spectacle-wear. Spectacle dependence was defined as subjects indicating any reliance on glasses for distance-vision and represents the summation of the “some of the time”, “half of the time”, “most of the time” and “all of the time” frequency-of-spectacle-wear responses. Consequently, fewer Model SA60TT subjects were spectacle dependent at 40.1% compared to 62.3% of the Model SA60AT subjects. **Figure 13** illustrates the distance-vision frequency-of-spectacle-wear distributions between Model SA60TT and Model SA60AT groups. Implantation of an AcrySof™ Toric Intraocular lens in astigmatic subjects provides significantly improved distance-vision spectacle independence relative to a conventional monofocal IOL.

**Figure 13: Distance-Vision Spectacle Independence: Frequency of Spectacle Wear, Form 5, All Implanted**

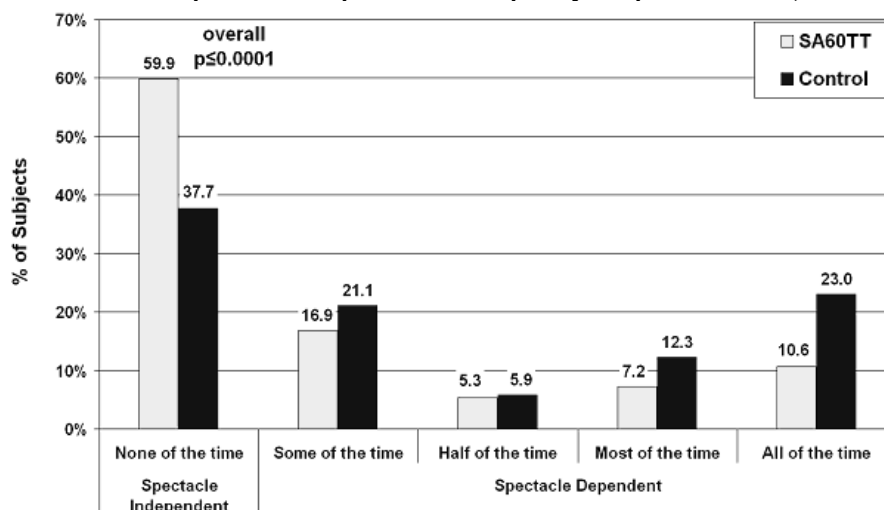

### 3. AcrySof™ TORIC HIGH CYLINDER POWER INTRAOCULAR LENS CLINICAL STUDY

#### Overview of Clinical Study

A clinical study was conducted to investigate the rates of spatial distortions related to axial misalignment of the AcrySof™ Toric Posterior Chamber High Cylinder Power Intraocular Lenses (Models SN60T6-SN60T9). The cylinder power at the IOL plane and corneal plane and the recommended correction ranges are shown in **Table 21**.

**Table 21: AcrySof™ Toric High Cylinder Power IOL:  
High Cylinder Powers and Recommended Correction Ranges**

Model	Cylinder Power		Toric Calculator Recommended Corneal Astigmatism Correction Ranges
	at IOL plane	at corneal plane	
SN60T6	3.75	2.57	2.57 – 3.07 D
SN60T7	4.50	3.08	3.08 – 3.59 D
SN60T8	5.25	3.60	3.60 – 4.10 D
SN60T9	6.00	4.11	4.11 D and up

These recommended corneal astigmatism correction ranges are based on the preoperative corneal astigmatism and the predicted effect of surgically induced astigmatism. To obtain the IOL cylindrical powers and the orientation of the surgical placement of the axes, for each operative eye the preoperative keratometry values and axes, IOL spherical power (as determined by the surgeon’s preferred formula), and the surgeon’s estimated surgically induced astigmatism (SIA) at the standard temporal incision location are entered into Alcon’s proprietary web-based AcrySof™ Toric IOL calculator. The combination of these parameters are used in the Alcon provided software to select the appropriate Toric IOL model and recommended axis of placement. As such, the recommended range of corneal astigmatism to be corrected while not identical, is directly related to, the preoperative keratometric cylinder.

The results achieved by the patients followed to six months (Visit 5A) postoperatively demonstrate that the AcrySof™ Toric High Cylinder Power IOL models are safe and effective for the visual correction of aphakia. The following clinical results illustrate the AcrySof™ Toric High Cylinder Power IOL’s effectiveness in significantly

**Clareon™ Toric Aspheric Hydrophobic Acrylic IOL  
w/ the AutonoMe™ Automated Pre-loaded Delivery System  
Model: CNA0T3-CNA0T9**

NOTE: Text appearing in gray is for information purposes only.

reducing pre-existing corneal astigmatism and the IOL's excellent rotational stability following implantation in the capsular bag.

**Subject Population**

This study focused on the highest cylinder power IOL Model SN60T9; however, due to the rarity of this level of astigmatism IOL Model SN60T8 was included to expand the inclusion criteria for the second eye. The subject population implanted with an IOL Model SN60T9 in the first operative eye consists of 80% (12/15) females and 20% (3/15) males. For the fellow eye, 3 subjects were implanted with IOL Model SN60T9, while 12 were implanted with IOL Model SN60T8. All 15 (100%) of the implanted subjects were white. The mean age for the population was 67 years old (range of 43 to 82 years) at the time of surgery.

**Absolute Residual Refractive Cylinder**

Refractive cylinder six months postoperatively was reduced for all subjects implanted with either an AcrySof™ Toric IOL Model SN60T8 or SN60T9 compared to preoperative baseline. Results show a statistically significant reduction (p-value <0.0001) in residual refractive cylinder in eyes implanted with IOL Model SN60T9 [85.7% in first eyes (n=15), 87.4% in second eyes (n=3) and IOL Model SN60T8 [87.3% (n=12)].

**Uncorrected Distance Visual Acuity**

All subjects implanted bilaterally with the AcrySof™ Toric IOL Models SN60T8 or SN60T9 achieved improved binocular uncorrected distance visual acuity six months postoperatively. **Figure 14** demonstrates that 60% of subjects achieved 20/20 or better binocular uncorrected distance visual acuity compared to 30% for monocular eyes, while 93% of subjects achieved 20/40 or better binocular uncorrected distance visual acuity compared to 90% of monocular eyes. Less than 10% of subjects had monocular or binocular uncorrected distance visual acuity worse than 20/40 six months postoperatively.

**Figure 14: Cumulative UCDVA Monocular versus Binocular**

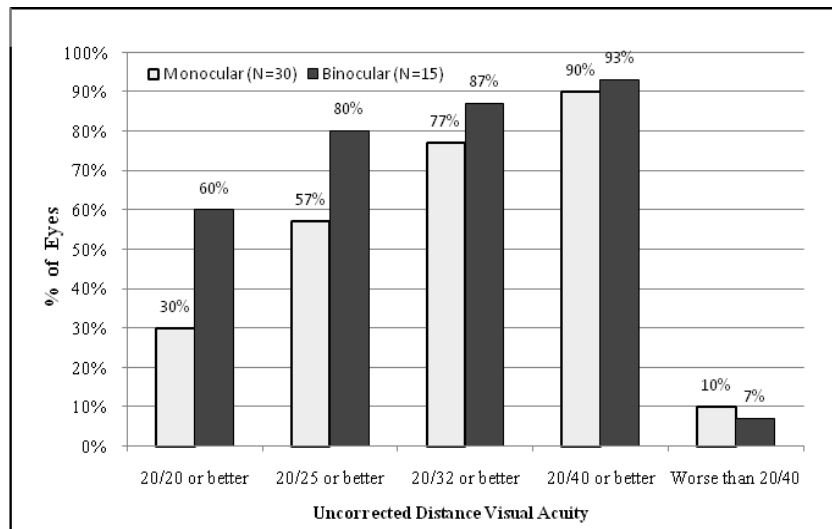

**Bilateral Distance-Vision Spectacle Independence**

Spectacle independence was assessed in the study by direct subject responses obtained from a self-reported, binocular subject questionnaire. Since the AcrySof™ Toric High Cylinder Power IOL study was initiated in August 2009, the questionnaire utilized was not developed using the US FDA guidance document "Patient-Reported Outcomes Measures: Use in Medical Product Development to Support Labeling Claims" dated December 2009.

Preoperatively all subjects were spectacle dependent, either all the time (92.9%) or some of the time (7.1%). Six months postoperatively, 71.4% of subjects were spectacle independent (**Figure 15**).

**Clareon™ Toric Aspheric Hydrophobic Acrylic IOL  
w/ the AutoMe™ Automated Pre-loaded Delivery System  
Model: CNA0T3-CNA0T9**

NOTE: Text appearing in gray is for information purposes only.

**Figure 15: Bilateral Distance Vision Spectacle Independence  
Frequency of Spectacle Wear Visit 0 (PreOp) versus Visit 5A (Final Visit)**

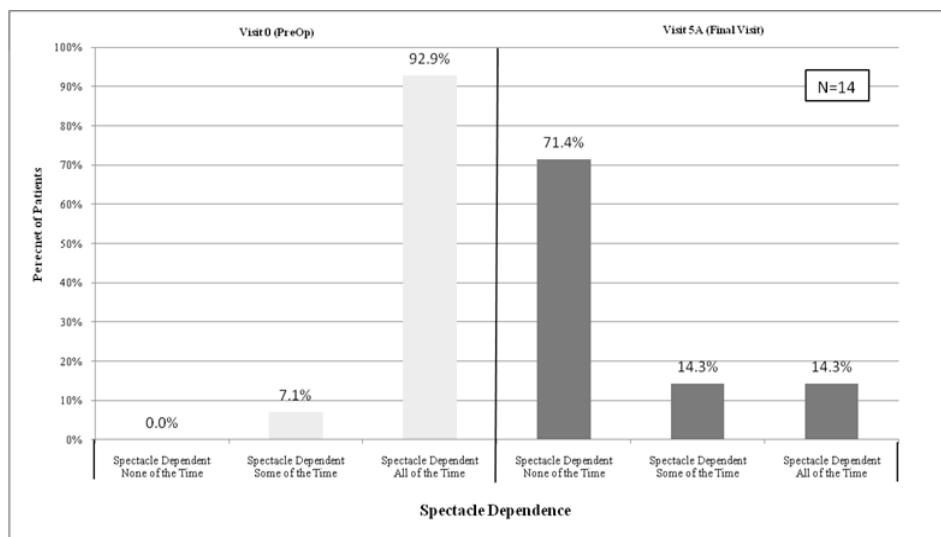

**Rate of Spatial Distortions**

The rate of spatial distortions was assessed in the study by direct subject responses obtained from a self-reported, binocular subject questionnaire. Since the AcrySof™ Toric High Cylinder Power IOL study was initiated in August 2009, the questionnaire utilized was not developed using the US FDA guidance document “Patient-Reported Outcomes Measures: Use in Medical Product Development to Support Labeling Claims” dated December 2009.

A visual distortion questionnaire was administered preoperatively (Visit 0) and at six months postoperatively (Visit 5A) to evaluate the rate of spatial distortions of the AcrySof™ Toric IOL Models SN60T8 and SN60T9. The overall rate of spatial distortions decreased postoperatively (Table 22A).

**Table 22A: AcrySof™ Toric High Cylinder Power IOL: Visual Distortion Questionnaire Results by Visit**

During the past 4 weeks, have you had		PreOp (N = 14)		Final Visit (N = 14)	
		n	%	n	%
1) ...trouble with things appearing distorted?	No	3	21.4	12	85.7
	Yes	11	78.6	2 <sup>a,b</sup>	14.3
2) ...trouble with flat surfaces (like floors) appearing curved?	No	12	85.7	13	92.9
	Yes	2	14.3	1 <sup>c</sup>	7.1
3) ...trouble with straight lines (like door or window frames) appearing tilted?	No	10	71.4	14	100
	Yes	4	28.6	0	0.0
4) ...trouble with feeling sick to your stomach due to distortion of your vision?	No	14	100	14	100
	Yes	0	0.0	0	0.0

<sup>a</sup>Reported with or without glasses at Preop and Final Visit.

<sup>b</sup>Reported with or without glasses at Preop but only with glasses (progressive lenses) at Final Visit.

<sup>c</sup>Same subject as in (b). Reported only with glasses (progressive lenses) at Final Visit. Not reported at Preop.

Based on these questions spatial distortions associated with high pre-existing corneal astigmatism may not completely resolve postoperatively. Two subjects at Visit 5A continued to report “trouble with things appearing distorted” versus 11 subjects preoperatively. One of these subjects had “trouble with flat surfaces appearing curved,” which was noted only postoperatively, but no longer experienced the preoperative visual phenomena of straight lines appearing tilted. Neither subject had IOL misalignment requiring secondary surgical intervention to address problems of spatial distortion. There were no reports of subjects feeling sick to their stomachs due to distortion of vision.

**Clareon™ Toric Aspheric Hydrophobic Acrylic IOL  
w/ the AutoMe™ Automated Pre-loaded Delivery System  
Model: CNA0T3-CNA0T9**

NOTE: Text appearing in gray is for information purposes only.

Responses to visual distortion sub-questions related to spectacle wear, frequency of experiencing distortion, and degree of bother are presented in **Tables 16B through 16D**.

**Table 22B: AcrySof™ Toric High Cylinder Power IOL:  
Visual Distortion Questionnaire Results – Trouble with Things Appearing Distorted**

1) For subjects who had trouble with things appearing distorted in the last 4 weeks:		PreOp (N = 11)		Final Visit (N = 2)	
		n	%	n	%
Do you notice this only when you wear your glasses?	No	10	90.9	1	50.0
	Yes	1	9.1	1	50.0
How often have you noticed this?	Rarely	2	18.2	0	0.0
	Sometimes	2	18.2	0	0.0
	Frequently	3	27.3	1	50.0
	All the time	4	36.4	1	50.0
How much does it bother you?	None	1	9.1	1	50.0
	A Little	4	36.4	0	0.0
	A Lot	6	54.5	1	50.0

**Table 22C: AcrySof™ Toric High Cylinder Power IOL:  
Visual Distortion Questionnaire Results – Trouble with Flat Surfaces Appearing Curved**

2) For subjects who had trouble with flat surfaces (like floors) appearing curved in the last 4 weeks:		PreOp (N = 2)		Final Visit (N = 1)	
		n	%	n	%
Do you notice this only when you wear your glasses?	No	2	100	0	0.0
	Yes	0	0.0	1	100
How often have you noticed this?	Rarely	0	0.0	0	0.0
	Sometimes	0	0.0	0	0.0
	Frequently	1	50.0	1	100
	All the time	1	50.0	0	0.0
How much does it bother you?	None	0	0.0	0	0.0
	A Little	0	0.0	0	0.0
	A Lot	2	100	1	100

**Table 22D: AcrySof™ Toric High Cylinder Power IOL:  
Visual Distortion Questionnaire Results – Trouble with Straight Lines Appearing Tilted**

3) For subjects who had trouble with straight lines (like door or window frames) appearing tilted in the last 4 weeks:		PreOp (N = 4)		Final Visit (N = 0)	
		n	%	n	%
Do you notice this only when you wear your glasses?	No	3	75.0	0	0.0
	Yes	1	25.0	0	0.0
How often have you noticed this?	Rarely	0	0.0	0	0.0
	Sometimes	2	50.0	0	0.0
	Frequently	0	0.0	0	0.0
	All the time	2	50.0	0	0.0
How much does it bother you?	None	0	0.0	0	0.0
	A Little	1	25.0	0	0.0
	A Lot	3	75.0	0	0.0

**Adverse Events**

During the study, 1 of 15 subjects underwent a secondary surgical intervention in the first eye to resolve residual refractive cylinder due to an error in preoperative keratometry. One week postoperatively, the IOL was repositioned. At six months postoperatively the subject was satisfied with uncorrected distance vision and did not experience any spatial distortion after IOL repositioning. No other serious adverse events were reported in the study.

**Clareon™ Toric Aspheric Hydrophobic Acrylic IOL  
w/ the AutoMe™ Automated Pre-loaded Delivery System  
Model: CNA0T3-CNA0T9**

NOTE: Text appearing in gray is for information purposes only.

**REFERENCES**

Abulafia A, Barrett GD, Kleinmann G, Ofir S, Levy A, Marcovich AL, *et al.* Prediction of refractive outcome with toric intraocular lens implantation. *J Cataract Refractive Surgery.* 2015; 41:936–944.

Abulafia A, Hill WE, Franchina M, Barrett GD. Comparison of methods to predict residual astigmatism after intraocular lens implantation. *J Refractive Surgery.* 2015b; 31(10):699-706.

Boettner, E.A. and Wolter, J.R. Transmission of the ocular media. *Invest. Ophthalmol.* 1962;1:776-83.

Haigis W. ULIB - User group for Laser Interference Biometry. Updated 2014 Jul 17; cited 2015 Mar 13. Available at: <http://ocusoft.de/ulib/>.

Hoffer KJ. The Hoffer Q formula: a comparison of theoretic and regression formulas. *J Cataract Refract Surg.* 1993;19(6):700-12.















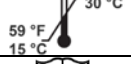

Holladay JT. Standardizing constants for ultrasonic biometry, keratometry, and intraocular lens power calculations. *J Cataract Refract Surg.* 1997;23(9):1356-70.

Ma JJ, Tseng SS. Simple method for accurate alignment in toric phakic and aphakic intraocular lens implantation. *J Cataract Refract Surg.* 2008;34:1631-6.

Olsen T. Calculation of intraocular lens power: a review. *Acta Ophthalmol Scand.* 2007;85(5):472-85.

Retzlaff JA, Sanders DR, Kraff M. *Lens Implant Power Calculation.* 3rd ed. Thorofare (NJ): Slack, Inc.; 1990.

**STAND ALONE SYMBOLS FROM ISO 7000/ISO 7001\* USED ON LABELING  
(ISO 7000 Title: Graphical Symbols for Use on Equipment)  
(\*ISO 7001 Title: Graphical symbols – Public information symbols)**











Symbol	Reference Number from ISO 7000 / ISO 7001*	Symbol Title / Explanatory Text
	1051	Do not re-use
	2608	Do not re-sterilize
	2607	Use-by date
	2501	Sterilized using ethylene oxide
	2498	Serial number
	2493	Catalogue number
	0434A	Caution
	3082	Manufacturer
	0632	Temperature Limit
	1641	Consult instructions for use
	3500	Electronic instructions for use
	2606	Do not use if package has been damaged
	2497	Date of Manufacture
	3079	Open Here
	3010	RFID tag, general
	5662	Date
	PI PF 002*	Hospital

\*This symbol is the only one from ISO 7001 in the table above.

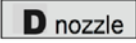
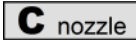
**Clareon™ Toric Aspheric Hydrophobic Acrylic IOL  
w/ the AutonoMe™ Automated Pre-loaded Delivery System  
Model: CNA0T3-CNA0T9**

NOTE: Text appearing in gray is for information purposes only.

**ABBREVIATIONS or SYMBOLS USED ON LABELING**

Symbol	Symbol Title / Explanatory Text
	Medical device
	Single sterile barrier system
IOL	Intraocular lens
OVD	Ophthalmic viscosurgical device
	UV and Blue Light Filter
	Posterior chamber IOL
UV	Ultraviolet
D	Diopter
Ø <sub>B</sub>	Body diameter (Optic diameter)
Ø <sub>T</sub>	Overall diameter (Overall length)
L	Left
R	Right
CYL	Cylinder Add Power
PWR	Spherical Equivalent Power
	D-size nozzle
	C-size nozzle
	Not made with natural rubber latex
	Does not contain PHT (phthalates)
	MR Safe
	Caution: Federal (USA) Law restricts this device to sale by or on the order of a physician
	Authorized Representative in the European Community



Alcon Laboratories, Inc.  
6201 South Freeway  
Fort Worth, Texas 76134-2099 USA

† Trademarks are the property of their respective owners.

**ALCON** (current approved logo)

<Insert copyright>

**Product: Clareon™ Toric Aspheric Hydrophobic Acrylic IOL**  
**Model: CNW0T3-CNW0T9**

Note: Text in gray is for informational purposes only

**Directions for Use**

<Note: Include revision date on approved DFU using YYYY-MM format>



<https://ifu.alcon.com>

XX-XXX-XXX-XXX (Insert Commodity Number)

**PRODUCT INFORMATION**

Alcon Laboratories, Inc.

Clareon™ Toric Aspheric Hydrophobic Acrylic IOL (logo)

**STERILE UV and Blue Light Filtering Acrylic Foldable  
Toric Aspheric Single-Piece Posterior Chamber Intraocular Lenses**



**DESCRIPTION**

The Clareon™ Toric Aspheric Hydrophobic Acrylic IOL (henceforth referred to as Clareon™ Toric IOL) is an ultraviolet and blue light filtering foldable single-piece posterior chamber intraocular lens. Each lens has an optical portion and mechanical support elements (haptics) composed of a high refractive index soft hydrophobic acrylic material capable of being folded prior to insertion, which contains a covalently bonded blue light filtering chromophore. Alcon's proprietary chromophore filters blue light in a manner that approximates the human crystalline lens in the 400 to 475 nm wavelength range (Boettner and Wolter, 1962). The optic portion is biconvex and includes an aspheric surface. After surgical insertion into the eye, the lens gently unfolds to a full-size lens body. The haptics provide proper positioning of the lens optic within the capsular bag.

The anterior aspheric surface of the Clareon™ Toric IOL is designed with negative spherical aberration to compensate for the positive spherical aberration of an average cornea. The effects of this aspheric design feature have not been clinically assessed on the Clareon™ Toric IOL. Additionally, these IOLs have a toric component on the posterior surface with axis marks to denote the flat meridian (plus cylinder axis). Alignment of the toric axis marks with the post-operative steep corneal meridian allows the lens to correct preexisting corneal astigmatism. The physical properties of this lens are described in **Figures 1 and 2** and **Table 1**.

**Table 1: Physical Characteristics of Clareon™ Toric IOLs**

Physical Characteristics	Description						
	IOL Model	CNW0T3	CNW0T4	CNW0T5	CNW0T6	CNW0T7	CNW0T8
Optic Type	Biconvex Toric Aspheric Optic						
Optic Material	Ultraviolet and Blue Light Filtering Hydrophobic Acrylate/Methacrylate Copolymer						
Spectral Transmission	10% transmittance at 403 nm (UV) for +20.0 diopter IOL						
Index Of Refraction	1.55 at 35°C						
Optic Powers	+6.0 to +30.0 diopters (in 0.5 diopter increments)						
IOL Cylinder Powers (D)	1.50	2.25	3.00	3.75	4.50	5.25	6.00
Haptic Configuration	STABLEFORCE™ Modified-L Haptics						
Haptic Material	Ultraviolet and Blue Light Filtering Hydrophobic Acrylate/Methacrylate Copolymer						
Optic Diameter Ø <sub>B</sub> (mm)	6.0						
Overall Length Ø <sub>T</sub> (mm)	13.0						
Haptic Angle	0°						

**HOW SUPPLIED**

The Clareon™ Toric Aspheric Hydrophobic Acrylic IOLs are supplied dry, in a package terminally sterilized with ethylene oxide, and must be opened only under aseptic conditions (see DIRECTIONS FOR USE).

CNW0T3-CNW0T9\_US DFU

Rev. 0120

Page 1 of 25

**Product: Clareon™ Toric Aspheric Hydrophobic Acrylic IOL**  
**Model: CNW0T3-CNW0T9**

Note: Text in gray is for informational purposes only

**Figure 1: Design of Clareon™ Toric IOLs**  
**Models CNW0T3-CNW0T9**  
(All dimensions in millimeters)

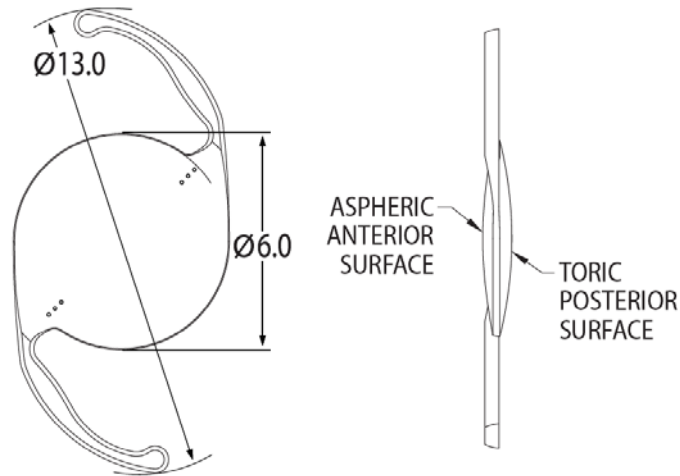

**Figure 2: Spectral Transmittance**

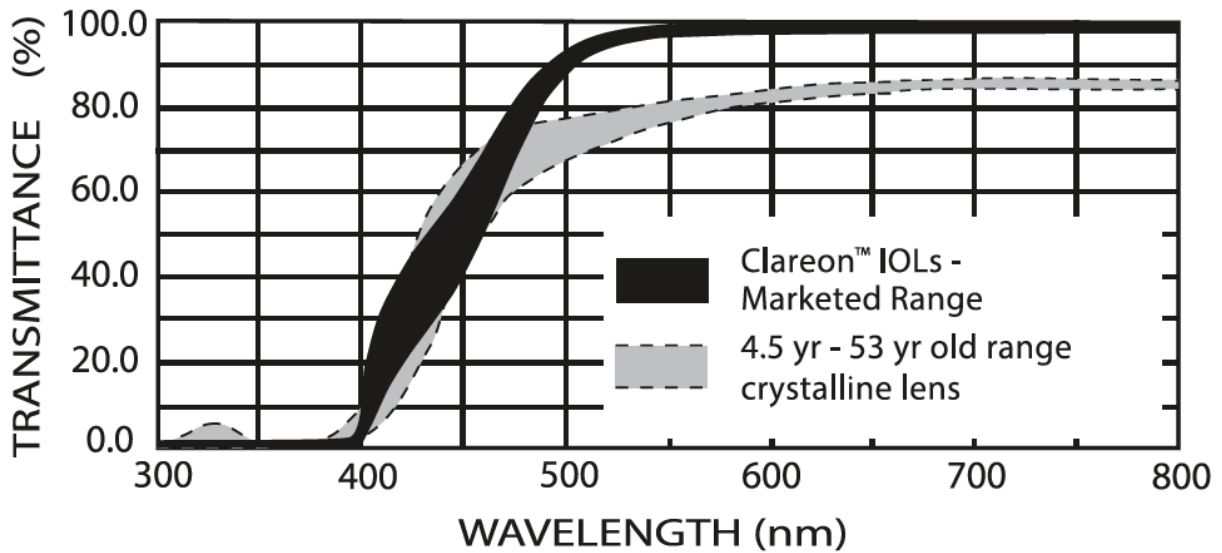

**NOTES:**

- The cutoff wavelength and the spectral transmittance curves presented here represent the range of transmittance values of IOLs made from hydrophobic acrylate/methacrylate copolymer with bonded UV-absorber and Alcon's proprietary blue light filtering chromophore.
- Measurements were by direct transmittance using Clareon™ IOLs with center thickness equivalent to the marketed range.
- Human lens data from Boettner and Wolter (1962).

**MODE OF ACTION (INTENDED USE)**

The Clareon™ Toric IOL is intended for use by a trained ophthalmic surgeon. The IOL is intended to be placed in the capsular bag in the posterior chamber of the eye, replacing the natural crystalline lens. This position allows the IOL to function as a refractive medium in the correction of aphakia and pre-existing corneal astigmatism. The aspheric biconvex toric optic compensates for the positive spherical aberration of the cornea as compared to a standard spherical optic. These IOLs have a toric optic with cylinder axis marks to denote the flat meridian (plus cylinder axis). Alignment of the toric axis marks with that of the postoperative steep corneal meridian allows this lens to reduce preexisting corneal astigmatism. The astigmatic correction at the corneal plane for each Clareon™ Toric IOL model is shown in **Table 2**.



**Product: Clareon™ Toric Aspheric Hydrophobic Acrylic IOL  
Model: CNW0T3-CNW0T9**

Note: Text in gray is for informational purposes only

**Table 2: Astigmatic Correction at the Corneal Plane for Clareon™ Toric IOLs**

IOL Model	Cylinder Power	
	IOL Power (Diopters)	Corneal Plane (Diopters) <sup>a</sup>
CNW0T3	1.50	0.98
CNW0T4	2.25	1.47
CNW0T5	3.00	1.96
CNW0T6	3.75	2.45
CNW0T7	4.50	2.94
CNW0T8	5.25	3.43
CNW0T9	6.00	3.92

<sup>a</sup>Based on an average pseudophakic human eye using an SRK/T optical A-constant of 119.1

**INDICATIONS**

The Clareon™ Toric Aspheric Hydrophobic Acrylic Intraocular Lenses (IOLs) are indicated for primary implantation in the capsular bag in the posterior chamber of the eye for visual correction of aphakia and pre-existing corneal astigmatism to reduce residual refractive cylinder and improve uncorrected distance vision in adult patients in whom a cataractous lens has been removed.

**QUALIFIED COMBINATIONS FOR IOL IMPLANTATION**

During implantation of Clareon™ Toric IOLs, an Alcon qualified delivery system and ophthalmic viscosurgical device (OVD) combination should be used. The use of an unqualified combination may cause damage to the lens and potential complications during the implantation process. Alcon recommends using the qualified MONARCH™ IOL Delivery System (Cartridge and Handpiece) or any other Alcon qualified combination. The qualified combinations that can be used with this lens are listed by row in **Table 3**.

**Table 3: Qualified Combinations of Compatible Products**

Lens Model	Diopter Range	Cartridge	Handpiece	Ophthalmic Viscosurgical Device (OVD)
CNW0T3- CNW0T6	+6.0 to +25.0	MONARCH™ III D (8065977763)	MONARCH™ III (blue) (8065977773)	VISCOAT™ OVD PROVISC™ OVD DISCOVISC™ OVD
	+6.0 to +30.0	MONARCH™ III C (8065977762)		
CNW0T7- CNW0T9	+6.0 to +21.0	MONARCH™ III D (8065977763)		
	+6.0 to +30.0	MONARCH™ III C (8065977762)		

Contact Alcon for any additional Alcon qualified OVDs, handpieces, and cartridges for use with this lens.

**CALCULATION OF LENS POWER**

Accurate biometry is essential for successful visual outcomes. Preoperative calculation of required lens power for the Clareon™ Toric IOL should be determined by the surgeon's experience and preference. A reference SRK/T A-Constant value for optical biometry equipment such as IOLMaster<sup>®</sup> or LenStar<sup>®</sup> as well as *contact* ultrasound biometry is listed on the outer label. The reference optical A-Constant anticipates the use of both corneal power and axial length values from optical biometry equipment with standard settings for a typical patient population and a spectacle far point at 6 meters. In general, A-constants must be "personalized" to compensate for such things as differences in instrumentation, surgical techniques, and IOL power calculation that may exist between clinical practices. IOL power calculation methods are often included with biometry equipment, and they are also described in the references (Hoffer 1993; Holladay 1997; Olsen 2007; Retzlaff, Sanders & Kraff 1990; Haigis 2014).

**WARNINGS**

1. The Clareon™ Toric IOL is intended for implantation in the capsular bag only. There are no clinical data to demonstrate its safety and effectiveness for placement in the ciliary sulcus.
2. DO NOT re-sterilize these intraocular lenses by any method.
3. DO NOT implant the IOL if the sterility has been compromised or if the sterile package has been unintentionally opened before use.

**Product: Clareon™ Toric Aspheric Hydrophobic Acrylic IOL**  
**Model: CNW0T3-CNW0T9**

Note: Text in gray is for informational purposes only

4. DO NOT reuse the IOL. This device is for single patient use only. Reuse of this single-use device may result in serious injury, such as but not limited to endophthalmitis.
5. Physicians considering lens implantation under any of the following circumstances should weigh the potential risk/benefit ratio: Patients in whom the posterior capsule is ruptured, zonules are damaged, or primary posterior capsulotomy is planned.
6. Rotation of the Clareon™ Toric IOL away from its intended axis can reduce the astigmatic correction. Each degree of misalignment of a toric IOL may reduce the cylinder power effect by approximately 3.3% (Ma 2008). If IOL repositioning is necessary, it should occur as early as possible, prior to IOL encapsulation. Some clinical cases suggest encapsulation is complete within four weeks of implantation.
7. It is recommended that OVD be removed from the eye at the close of surgery with emphasis on the space between the posterior capsule and lens. This may be accomplished by gently depressing the IOL optic posteriorly with the I/A tip and using standard irrigation/aspiration techniques to remove the OVD from the eye. This should force any trapped OVD anteriorly where it can be easily aspirated. Residual OVD may allow the lens to rotate causing misalignment of the Clareon™ Toric IOL with the intended axis of placement.

### PRECAUTIONS

1. A high level of surgical skill is required for intraocular lens implantation. The surgeon should have observed and/or assisted in numerous implantations and successfully completed one or more courses on intraocular lens implantation before attempting to implant intraocular lenses.
2. Prior to surgery, prospective patients should be informed of the possible risks and benefits associated with this IOL as well as the risks and benefits associated with cataract surgery. After surgery, physicians should provide an implant card to patients regarding the IOL implanted.
3. The safety and effectiveness of the Clareon™ Toric IOL has not been substantiated in clinical trials in patients with certain pre-existing conditions and/or intraoperative conditions (listed in **Tables 4 and 5**) as these patients were excluded from the clinical studies. Patients with pre-existing conditions may not achieve the visual acuity of patients without such conditions. As with the implantation of any IOL, careful preoperative evaluation and sound clinical judgment should be used by the surgeon to decide the benefit/risk ratio before implanting a lens in a patient with one or more of these conditions.
4. Follow the section regarding directions for use (see below) for information on the maximum allowed time for the IOL to stay in the folded condition. Failure to adhere to manufacturer's recommendations may result in IOL damage.
5. DO NOT store the intraocular lenses over 30 °C (86 °F).
6. Accurate keratometry and biometry, in addition to the use of the Toric Calculator for the Clareon™ Toric IOL models (<http://www.myalcon-toriccalc.com>), are recommended to achieve optimal visual outcomes.
7. For models CNW0T6 to CNW0T9, patients with postoperative refractive error may not receive the aspheric optical design benefit without spectacle correction.
8. For models CNW0T6 to CNW0T9, optical theory suggests that high astigmatic patients may experience spatial distortions. Possible toric IOL related factors may include residual cylindrical error or axis misalignments.
9. As with any surgical procedure, there is risk involved. Potential complications accompanying cataract and/or IOL implantation surgery may include, but are not limited to, the following: lens epithelial cell on-growth, corneal cell endothelial damage, infection (endophthalmitis), toxic anterior segment syndrome (TASS), retinal detachment, vitritis, cystoid macular edema, corneal edema, pupillary block, cyclitic membrane, iris prolapse, hypopyon, anterior uveitis, hyphema, pigment dispersion, posterior capsule opacification, transient or persistent glaucoma, and secondary surgical interventions. Secondary surgical interventions include, but are not limited to: lens repositioning, lens replacement, vitreous aspiration or iridectomy for pupillary block, wound leak repair, and retinal detachment repair.

**Product: Clareon™ Toric Aspheric Hydrophobic Acrylic IOL**  
**Model: CNW0T3-CNW0T9**

Note: Text in gray is for informational purposes only

**Table 4: Preexisting Conditions with No Safety and Effectiveness Data**

<ul style="list-style-type: none"><li>• Clinically severe corneal dystrophy (e.g., epithelial, stromal, or endothelial dystrophy), keratitis, keratoconjunctivitis, keratouveitis, keratopathy, or kerectasia</li><li>• Irregular corneal astigmatism</li><li>• Previous corneal transplant</li><li>• Aniridia</li><li>• Iris neovascularization</li><li>• Uncontrolled glaucoma</li><li>• Rubella, congenital, traumatic, or complicated cataracts</li><li>• Extremely shallow anterior chamber, not due to swollen cataract</li><li>• Clinically significant macular degeneration</li><li>• Previous retinal detachment</li><li>• Diabetic retinopathy</li></ul>	<ul style="list-style-type: none"><li>• Optic nerve atrophy</li><li>• Recurrent anterior or posterior segment inflammation of unknown etiology, or any disease producing an inflammatory reaction in the eye (e.g., iritis or uveitis)</li><li>• Amblyopia</li><li>• Pre-existing ocular conditions which may negatively impact stability of the implant (e.g., diagnosis of pseudoexfoliation syndrome)</li><li>• Microphthalmos</li><li>• Previous corneal or refractive surgery</li><li>• Current or recent usage of alpha-1-selective adrenoceptor blocking agent or antagonist of alpha 1A adrenoceptor [e.g., Flomax<sup>†</sup> (tamsulosin HCL), Hytrin<sup>†</sup>, or Cardura<sup>†</sup>]</li><li>• Pregnancy</li></ul>
--	--

**Table 5: Intraoperative Conditions with No Safety and Effectiveness Data**

<ul style="list-style-type: none"><li>• Other additional procedures during cataract surgery due to intraoperative complications that require further intervention (e.g., posterior rupture with vitreous loss)</li><li>• Excessive iris mobility</li><li>• Mechanical or surgical manipulation required to enlarge the pupil</li></ul>	<ul style="list-style-type: none"><li>• Vitreous loss (significant)</li><li>• Anterior chamber bleeding (significant)</li><li>• Complications in which the IOL stability could be compromised, including but not limited to zonular or capsular rupture or zonular weakness</li><li>• Inability to place IOL in capsular bag due to surgical complications</li></ul>
--	--

**SELECTION OF TORIC IOL**

For selection of the appropriate toric IOL, Alcon provides a web-based tool ([www.myalcon-toriccalc.com](http://www.myalcon-toriccalc.com), Abulafia, Barrett, et al. 2015 and Abulafia, Hill, et al. 2015) that uses pre-operative biometry data, incision location, and surgically induced corneal astigmatism. The astigmatism to be corrected should be determined from biometry data rather than refractive data since the presence of lenticular astigmatism in the crystalline lens to be removed may influence results.

**AXIS PLACEMENT OF TORIC IOL**

For optimal results, the surgeon must ensure the correct placement and orientation of the lens within the capsular bag. The posterior surface of the IOL is marked with indentations (three at each end) at the haptic/optic junction that identify the flat meridian of the toric IOL optic. These indentations form an imaginary line representing the plus cylinder axis (note: IOL cylinder steep meridian is 90° away). The cylinder axis marks should be aligned with the post-incision steep corneal meridian (intended axis of placement) or as determined by the web-based IOL calculator.

Prior to surgery, the lens placement axis should be marked. One way used in clinical practice to mark the eye is as follows: With the patient sitting upright to prevent cyclotorsion, clearly and precisely mark two reference positions with a surgical skin marker or a marking pencil indicated for ophthalmic use. Using these marks as reference points, an axis marker can be used immediately prior to or during surgery to mark the optimal axis of lens placement identified by the web-based IOL calculator ([www.myalcon-toriccalc.com](http://www.myalcon-toriccalc.com)).

Precisely align the axis marking indentations on the toric IOL with the marked intended axis of lens placement. Remove all OVD from both the anterior and posterior sides of the lens since residual OVD may allow the lens to rotate causing misalignment of the toric IOL with the intended axis of placement. This may be accomplished by manipulating the IOL optic with the I/A tip and using standard irrigation/aspiration techniques to remove all OVD from the eye. Bimanual techniques may be used, if preferred, to ensure removal of OVD from behind the lens implant. Special care should be taken to ensure proper positioning of the toric IOL at the intended axis following OVD removal.

Misalignment of the axis of the lens versus the intended axis of placement may compromise its astigmatic correction. Such misalignment can result from inaccurate keratometry or marking of the cornea, inaccurate placement of the

**Product: Clareon™ Toric Aspheric Hydrophobic Acrylic IOL**  
**Model: CNW0T3-CNW0T9**

Note: Text in gray is for informational purposes only

---

toric IOL axis during surgery, an unanticipated surgically induced change in the cornea, or physical rotation of the toric IOL after implantation. In order to minimize this effect, the surgeon should be careful to ensure that preoperative keratometry and biometry is accurate and that the IOL is properly oriented prior to the end of surgery.

**DIRECTIONS FOR USE**

1. Examine the label on the outer box for model, spherical equivalent power, cylinder power, proper configuration, and expiration date.
2. After the outer box is open, verify lens primary label information (e.g., model, powers, and serial number) is consistent with information on outer box labeling.
3. Inspect the primary package carefully for tears, cuts, punctures, or other signs that the pouch has been opened or damaged. This device is sterile until the primary package is opened. DO NOT implant the IOL if the sterility has been compromised or if the sterile package has been unintentionally opened before use (see RETURNED GOODS POLICY).
4. Open the undamaged primary package and transfer the case to a sterile environment. Carefully open the case to expose the lens.
5. Use instrumentation that is scrupulously clean to minimize the occurrence of marks. Any forceps used for lens handling must have round edges and smooth surfaces.
6. Handle the IOL by the haptics only when removing the lens from the case. DO NOT grasp the optical area with forceps. Handle lenses carefully to avoid damage to lens surfaces or haptics. DO NOT attempt to reshape haptics in any way.
7. Examine the IOL carefully prior to insertion to ensure that particles have not adhered during handling.
8. Implant the IOL with the most appropriate surgical procedure for the patient. Surgeons should verify that appropriate instrumentation is available prior to surgery. Refer to Table 3 for qualified combinations of compatible products.

**NOTE: During lens loading and insertion, DO NOT allow the Clareon™ Toric IOL to remain in a folded condition within the selected IOL Delivery System for more than 3 minutes prior to completing insertion into the capsular bag.**

**MAGNETIC RESONANCE COMPATIBILITY**

The Clareon™ Toric IOL is magnetic resonance (MR) Safe. The IOL consists of acrylate/methacrylate copolymer material, which is a non-conducting, non-metallic, non-magnetic material that poses no known hazards in all magnetic resonance imaging environments.

**PATIENT REGISTRATION**

The Patient Identification Card included in the package is to be completed and given to the patient, together with instructions to keep the card as a permanent record to be shown to any eye care practitioner that the patient consults in the future.

Each patient must be registered with Alcon Laboratories, Inc., immediately following implantation of one of these lenses. Registration is accomplished by completing the Implant Registration Card that is enclosed in the lens box and mailing it to Alcon Laboratories, Inc. Patient registration is essential for the long-term patient follow-up program and will assist Alcon Laboratories, Inc. in responding to reports of adverse events.

**SERIOUS INCIDENT REPORTING**

Any serious incident that may reasonably be regarded as device related should be reported to Alcon Laboratories, Inc.:

By Phone:  
In USA - (800) 757-9780  
Website:

<http://www.alcon.com/contact-us/>

Each IOL is identified by a serial number which provides traceability, and this information should be given to Alcon.

**EXPIRATION DATE**

Sterility is guaranteed unless the pouch is damaged or opened. The expiration date is clearly indicated on the outside of the lens package. Any lens held after the expiration date should be returned to Alcon Laboratories, Inc. (see RETURNED GOODS POLICY).

**Product: Clareon™ Toric Aspheric Hydrophobic Acrylic IOL**  
**Model: CNW0T3-CNW0T9**

Note: Text in gray is for informational purposes only

### RETURNED GOODS POLICY

Returned lenses will only be accepted in exchange for other products, not credit. All returns must be accompanied by an Alcon Laboratories, Inc. Returned Goods Number and should be shipped via traceable means. A Returned Goods Number is obtained by contacting Alcon Laboratories, Inc. Customer Service Department. Issuance of this number does not constitute final acceptance of the returned products. For detailed policy guidelines including exchange, please contact your Sales or Customer Service Representative.

### CLINICAL STUDIES

Three prospective clinical studies with other Alcon IOLs were performed that support the safety and effectiveness of the Clareon™ Toric IOL (Models CNW0T3-CNW0T9) and are described in this labeling: †

1. Data from the US study of Clareon™ IOL demonstrate favorable visual acuity and adverse event outcomes of the Clareon™ IOL. IOL rotational stability of the Clareon™ IOL was also assessed and are shown below to support Clareon™ Toric IOL along with safety data to support the Clareon™ material.
2. AcrySof™ Toric IOL (Models SA60T3-SA60T5) clinical study data are presented to describe the safety and effectiveness of the toric optical design of the Clareon™ Toric IOL.
3. AcrySof™ Toric High Cylinder Power IOL (Models SA60T8 and SA60T9) clinical study data are presented to describe the safety and effectiveness of the high cylinder toric optical design of the Clareon™ Toric IOL.

Summaries of these clinical studies are provided below to describe the performance characteristics of the Clareon™ Toric IOL. Please use caution when comparing these results with results from similar device studies due to potential differences in patient cohorts, test methods, etc.

†NOTE: Data from clinical studies with other Alcon IOLs (i.e., AcrySof™ Toric IOL and Clareon™ IOL) support the safety and effectiveness of the Clareon™ Toric IOL (Models CNW0T3-CNW0T9).

- The aspheric feature, which is also on the anterior side of the Clareon™ Toric IOL, is identical to the clinically studied Clareon™ IOL.
- The toric feature, which is also on the posterior side of the Clareon™ Toric IOL, is identical to the clinically studied AcrySof™ Toric IOL.
- The Clareon™ material will not affect the performance of the toric or aspheric features as the mechanical design, optical design, and optical performance specifications are maintained between the Clareon™ Toric IOL and AcrySof™ Toric IOL.

#### 1. STUDY RESULTS FOR Clareon™ ASPHERIC HYDROPHOBIC ACRYLIC IOL

A prospective, multicenter, open-label clinical study in adult subjects requiring cataract surgery with IOL implantation was performed on the Clareon™ IOL in the United States. The objective of this study was to demonstrate favorable visual acuity and adverse event outcomes for the Clareon™ IOL compared to historical safety and performance endpoint (SPE) rates as reported in EN ISO 11979-7:2014. The results achieved by the subjects successfully followed for 12 Months postoperatively (defined as 330 to 420 days postoperative) provide reasonable assurance that the Clareon™ IOL is a safe and effective device for the visual correction of aphakia following cataract surgery. The subject population in the clinical study consisted of 350 subjects in need of cataract surgery that were unilaterally implanted, the percentage of females (60.9%) exceeded the percentage of males (39.1%) enrolled. The mean age for the total population was 69.7 years.

#### Visual Acuity

The best corrected distance visual acuity (BCDVA) achieved at one year postoperatively by the Best Case Analysis Set is presented in **Table 6** and visual acuity achieved by All-Implanted Analysis Set is presented in **Table 7**. Similar data for BCDVA expressed as Snellen values are presented in **Tables 8** and **9**. The Best Case analysis included all eyes successfully implanted with the test article, had at least one postoperative visit, did not have any ocular pathology at Visit 0 (preoperative), had no macular degeneration at any visit, and did not have any previous surgery for the correction of refractive errors. All-Implanted Analysis set includes all eyes with successful test article implantation.

The one-sided exact 95% upper confidence limit for the percentage of subjects with monocular BCDVA of 0.3 logMAR or better at 12 months postoperative (Visit 5) is greater than or equal to the SPE rates as reported in EN ISO 11979-7:2014.

The uncorrected distance visual acuity (UCDVA) at one year postoperatively is presented in **Table 10** for the Best Case Analysis, and UCDVA achieved by All-Implanted Analysis Set is presented in **Table 11**.

**Product: Clareon™ Toric Aspheric Hydrophobic Acrylic IOL**  
**Model: CNW0T3-CNW0T9**

Note: Text in gray is for informational purposes only

**Table 6: Best Corrected Visual Acuity in the Best Case Analysis Set at Month 12, Clareon™ IOL**

<b>Visual Acuity</b>	<b>n</b>	<b>%</b>
0.0 logMAR or better	271	83.1
0.1 logMAR or better	307	94.2
0.2 logMAR or better	323	99.1
0.3 logMAR or better	325	99.7
Worse than 0.3 logMAR	1	0.3
ISO SPE Rate for % of 0.3 logMAR or better	96.7%	
N	326	
ISO SPE Rate = BS EN ISO 11979-7:2014, Ophthalmic Implants - Intraocular Lenses - Part 7: Clinical Investigations, Table B.4 - Posterior Chamber IOL Adverse Event Safety and Performance Endpoint Rates		

**Table 7: Best Corrected Visual Acuity in the All-Implanted Analysis Set at Month 12, Clareon™ IOL**

<b>Visual Acuity</b>	<b>n</b>	<b>%</b>
0.0 logMAR or better	277	81.0
0.1 logMAR or better	318	93.0
0.2 logMAR or better	339	99.1
0.3 logMAR or better	341	99.7
Worse than 0.3 logMAR	1	0.3
ISO SPE Rate for % of 0.3 logMAR or better	92.5%	
N	342	
ISO SPE Rate = BS EN ISO 11979-7:2014, Ophthalmic Implants - Intraocular Lenses - Part 7: Clinical Investigations, Table B.3 - Posterior Chamber IOL Adverse Event Safety and Performance Endpoint Rates		

**Table 8: Best Corrected Visual Acuity in the Best Case Analysis Set at Month 12 (Snellen), Clareon™ IOL**

<b>Visual Acuity</b>	<b>n</b>	<b>%</b>
20/20 or better	287	88.0
20/25 or better	316	96.9
20/32 or better	324	99.4
20/40 or better	325	99.7
Worse than 20/40	1	0.3
N	326	
Note: 20/20 = 0.04 logMAR      20/25 = 0.14 logMAR      20/32 = 0.24 logMAR 20/40 = 0.34 logMAR		

**Product: Clareon™ Toric Aspheric Hydrophobic Acrylic IOL  
Model: CNW0T3-CNW0T9**

Note: Text in gray is for informational purposes only

**Table 9: Best Corrected Visual Acuity in the All-Implanted Analysis Set at Month 12 (Snellen), Clareon™ IOL**

<b>Visual Acuity</b>	<b>n</b>	<b>%</b>
20/20 or better	297	86.8
20/25 or better	331	96.8
20/32 or better	340	99.4
20/40 or better	341	99.7
Worse than 20/40	1	0.3
N	342	
Note: 20/20 = 0.04 logMAR      20/25 = 0.14 logMAR      20/32 = 0.24 logMAR 20/40 = 0.34 logMAR		

**Table 10: Uncorrected Visual Acuity in the Best Case Analysis Set at Month 12, Clareon™ IOL**

<b>Statistic</b>	<b>(N = 334)</b>
n	326
Mean (SD)	0.042 (0.1348)
Median	-0.02
(Min, Max)	(-0.20, 0.70)
95% CI	(-0.027, -0.056)

**Table 11: Uncorrected Visual Acuity in the All-Implanted Analysis Set at Month 12, Clareon™ IOL**

<b>Statistic</b>	<b>(N = 350)</b>
n	342
Mean (SD)	0.043 (0.1339)
Median	0.02
(Min, Max)	(-0.20, 0.70)
95% CI	(0.029, 0.057)

**IOL Rotation**

The rotational stability of the Clareon™ IOL was evaluated in a subset of the total study population, which included 141 subjects at 6 sites. Results were compared to performance targets in EN ISO 11979-7:2014, defined as the difference between IOL axis orientation on day of surgery and at the Month 6 visit. A total of 98.4% of subjects had IOL rotation <10 degrees and 99.2% had rotation <20 degrees or <30 degrees at Month 6 compared to the day of surgery, which met the pre-specified performance targets. Results shown in **Table 6**.

**Product: Clareon™ Toric Aspheric Hydrophobic Acrylic IOL  
Model: CNW0T3-CNW0T9**

Note: Text in gray is for informational purposes only

**Table 12: Categorical Statistics for Absolute IOL Rotation (10 Degrees Increment) at Month 6 from Day of Surgery, Rotation Analysis Set, Clareon™ IOL**

	<b>(N=141)</b>	
Category	n	%
Total	124	-
Less than 10 degrees	122	98.4
Less than 20 degrees	123	99.2
Less than 30 degrees	123	99.2
Greater than 30 degrees	1	0.8
N = Number of eyes in the analysis set n = Number of eyes in specified category Total = Number of eyes with data Percentages are calculated as (n/Total) * 100		

In an additional analysis between Month 1 and Month 6, 98.4% of subjects implanted with the Clareon™ IOL had an absolute rotation of less than or equal to 5 degrees. The remaining subjects (1.6%) had rotation between 5 to 10 degrees.

Absolute rotation of Clareon™ IOL were also described at all post-operative visits (1 Day, 1 Week, 1 Month, and 6 Months) compared to the day of surgery. Descriptive statistics results at each postoperative visit are shown in **Table 13**.

**Table 13: Descriptive Statistics for Absolute IOL Rotation (Degrees), Rotation Analysis Set, Clareon™ IOL**

Visit	Statistic	<b>(N = 141)*</b>
1 Day	n	127
	Mean (SD)	1.8483 (3.72254)
	Median	0.942
	(Min, Max)	(0.002, 38.232)
	95% CI	(1.1946, 2.5020)
1 Week	n	126
	Mean (SD)	1.9942 (3.86948)
	Median	1.213
	(Min, Max)	(0.020, 40.547)
	95% CI	(1.3119, 2.6764)
1 Month	n	127
	Mean (SD)	2.2335 (3.95863)
	Median	1.414
	(Min, Max)	(0.008, 41.110)
	95% CI	(1.5384, 2.9287)
6 Months	n	124
	Mean (SD)	2.2696 (3.87231)
	Median	1.449
	(Min, Max)	(0.014, 40.033)
	95% CI	(1.5812, 2.9579)
N = Number of eyes in the analysis set n = Number of eyes at visit with data SD = Standard Deviation, CI = Confidence Interval * Of 141, 10 had images at baseline which were not readable and at each visit, individual subjects may have had images which were missing or not readable		

**Adverse Events**

The cumulative and persistent adverse events rates for the Safety Analysis Set are presented in **Table 14**. Cumulative adverse events are those that occur at any point in the study while persistent adverse events are those that occur or are ongoing at the 12 Month Visit. The Safety Analysis Set included all eyes with attempted implantation with the test article (successful or aborted after contact with the eye). In this study, the number of eyes in the Safety Analysis Set was equivalent to the All-Implanted Analysis Set.



**Product: Clareon™ Toric Aspheric Hydrophobic Acrylic IOL**  
**Model: CNW0T3-CNW0T9**

Note: Text in gray is for informational purposes only

For both cumulative and persistent adverse events, the exact one-sided 95% lower confidence limit of cumulative and persistent adverse events were within limits compared to the SPE rates reported in EN ISO 11979-7:2014.

**Table 14: Cumulative and Persistent Adverse Events in the Safety Analysis Set, Clareon™ IOL**

	(N = 350)			
	n (%)	2-sided 95% CI	1-sided 95% Lower CL	SPE %
<b>Cumulative Serious Adverse Events</b>				
Cystoid macular oedema	3 (0.9)	(0.18, 2.48)	0.23	3.0
Hypopyon	0 (0.0)	(0.00, 1.05)	0.00	0.3
Endophthalmitis	0 (0.0)	(0.00, 1.05)	0.00	0.1
Lens dislocated from posterior chamber	0 (0.0)	(0.00, 1.05)	0.00	0.1
Pupillary block	0 (0.0)	(0.00, 1.05)	0.00	0.1
Retinal detachment	0 (0.0)	(0.00, 1.05)	0.00	0.3
Secondary surgical intervention*	6 (1.7)	(0.63, 3.69)	0.75	0.8
<b>Other</b>				
Herpes virus infection	1 (0.3)	(0.01, 1.58)	0.01	NA
Macular fibrosis	1 (0.3)	(0.01, 1.58)	0.01	NA
Macular hole	1 (0.3)	(0.01, 1.58)	0.01	NA
Punctate keratitis	1 (0.3)	(0.01, 1.58)	0.01	NA
Retinal tear	2 (0.6)	(0.07, 2.05)	0.10	NA
<b>Persistent Serious Adverse Events</b>				
Corneal stroma oedema	0 (0.0)	(0.00, 1.05)	0.00	0.3
Cystoid macular oedema	1 (0.3)	(0.01, 1.58)	0.01	0.5
Iritis	0 (0.0)	(0.00, 1.05)	0.00	0.3
Raised IOP requiring treatment	0 (0.0)	(0.00, 1.05)	0.00	0.4
CI = Confidence Interval CL = Confidence Limit SPE = Safety and Performance Endpoint Persistent = Present or ongoing at the final scheduled visit IOP = Intraocular Pressure SPE rates are from BS EN ISO 11979-7:2014, Ophthalmic Implants - Intraocular Lenses - Part 7: Clinical Investigations, Table B.2 - Posterior Chamber IOL Adverse Event Safety and Performance Endpoint Rates If an eye has multiple occurrences of an AE, the eye is presented only once in the respective eye count column (n) for the corresponding AE. "Other" includes the MedDRA Preferred Term for ocular SAEs that do not belong to any predefined SPE categories. Percentages are calculated as (n/N) * 100. The SPE rate is considered not exceeded if the 1-sided 95% lower CL for an AE is less than the SPE%. *None of these secondary surgical interventions were related to the IOL.				

**IOL Observations**

At all five scheduled postoperative visits and at unscheduled visits, slit-lamp examinations were performed. The list of pre-specified slit-lamp findings included IOL observations, which were described as IOL glistenings, scratches/cracks on the IOL, and surface haze on the IOL. Across 1,852 postoperative (including unscheduled) visits, no IOL observations (IOL glistenings, scratches/cracks on the IOL, and surface haze on the IOL) were noted for the Clareon™ IOL.

**2. AcrySof™ TORIC INTRAOCULAR LENS CLINICAL STUDY**

Bench studies have demonstrated equivalent optical performance between the AcrySof™ Toric IOL and the Clareon™ Toric IOL. Accordingly, the data presented in this section and the data presented in the section on AcrySof™ Toric Posterior Chamber High Cylinder Power IOLs are applicable to both AcrySof™ and Clareon™ Toric IOLs.

**Overview of Clinical Study**

**Product: Clareon™ Toric Aspheric Hydrophobic Acrylic IOL  
Model: CNW0T3-CNW0T9**

Note: Text in gray is for informational purposes only

A multicenter, subject-masked, randomized, prospective clinical study was performed in the United States to evaluate the safety and effectiveness of AcrySof™ Toric IOL (Models SA60T3-SA60T5), collectively referred to as SA60TT) compared to Model SA60AT as control lens when implanted into the capsular bag following phacoemulsification. In this study, the results achieved by the subjects successfully followed for 6 months postoperatively (defined as 120 to 180 days postoperative after the second eye implant) provide reasonable assurance that the AcrySof™ Toric IOL is a safe and effective device for the visual correction of aphakia and pre-existing corneal astigmatism following cataract surgery.

Only data from the first operative eye from those subjects who received either a Model SA60TT or Model SA60AT intraocular lens are included. Three different lens models of varying cylinder correction were evaluated in this clinical study. The three different models evaluated and their applicable cylinder powers are listed in **Table 15**.

**Table 15: AcrySof™ Toric IOL: IOL Models and Cylinder Power in Clinical Study**

IOL Model**	Cylinder Power		Recommended Corneal Astigmatism Correction Ranges
	at IOL plane	at corneal plane	
SA60T3	1.50	1.03	0.75 - 1.50 D
SA60T4	2.25	1.55	1.50 - 2.00 D
SA60T5	3.00	2.06	2.00 D & up

\*\*These IOL models are collectively referred to as SA60TT in the text that follows.

The recommended corneal astigmatism correction ranges are based on 1) the preoperative corneal astigmatism and 2) the predicted effect of 0.5 diopter surgically induced astigmatism for a standardized temporal incision. The combination of these two parameters is used in Alcon provided software to select the appropriate Toric IOL model and recommended axis of placement. As such, the recommended range of corneal astigmatism to be corrected while not identical, is directly related to, the preoperative keratometric cylinder.

**Subject Population**

Specific requirements for study participation included (1)  $\geq 0.75$  D of preoperative With-the-Rule or preoperative oblique regular corneal astigmatism and (2)  $\geq 1.00$  D of preoperative Against-the-Rule regular corneal astigmatism. The subject population implanted with a Model SA60TT in the first operative eye consists of 53.3% females and 46.7% males. The subject population implanted with the Model SA60AT (control) intraocular lens consists of 57.2% females and 42.8% males. Stratifying by race for the Model SA60TT population, 97.6% are Caucasian, 2.0% are Black, and 0.4% are other. The control (SA60AT) population is 95.6% Caucasian, 1.6% Black, 1.2% Asian and 1.6% other. The mean age for the population receiving the Model SA60TT and SA60AT were 70.0 and 72.4, respectively.

**Uncorrected Distance Visual Acuity (UCDVA)**

A summary of uncorrected distance visual acuity achieved for Models SA60TT and SA60AT at six months postoperatively (Form 5 visit) is presented in **Table 16**.

**Table 16: Uncorrected Distance Visual Acuity, Status at Form 5  
Lens Models SA60TT and SA60AT, All Implanted**

	Sample size	Acuity										20/40 or better	
		20/20 or better		20/25		20/32		20/40		Worse than 20/40			
		N	n	%	n	%	n	%	n	%	n	%	n
Total (SA60TT)	211	81	38.4	59	28.0	36	17.1	22	10.4	13	6.2	198	93.8
Total (SA60AT)	210	40	19.0	46	21.9	37	17.6	39	18.6	48	22.9	162	77.1

At six months postoperatively (Form 5 visit), shown in **Figure 3**, 93.8% of Model SA60TT subjects achieved 20/40 or better UCDVA (first operative eye of the All Implanted data set) compared to 77.1% of the subjects implanted with the control Model SA60AT. The difference in UCDVA between Models SA60TT and SA60AT was statistically significant (all p-values  $\leq 0.0001$ ) in favor of Model SA60TT.

**Product: Clareon™ Toric Aspheric Hydrophobic Acrylic IOL  
Model: CNW0T3-CNW0T9**

Note: Text in gray is for informational purposes only

**Figure 3: Cumulative UCDVA, Status at Form 5, Model SA60TT vs. Control**

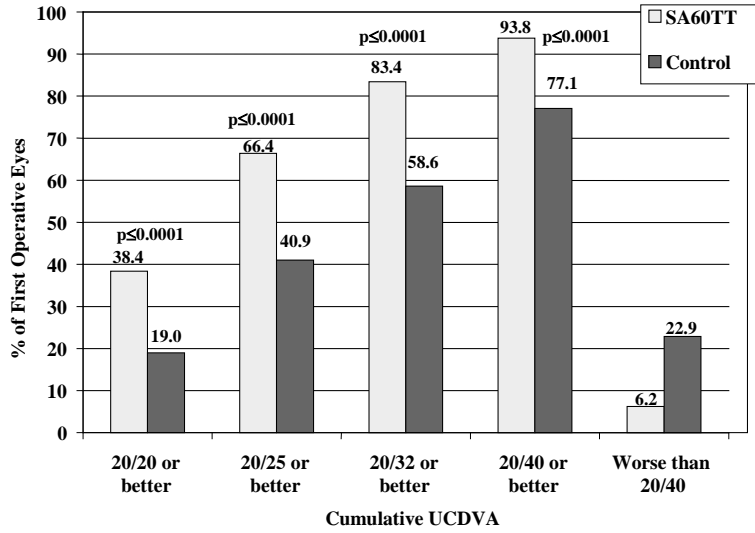

Similar results were noted when data was analyzed by cylinder range:

- The difference in cumulative UCDVA between Models SA60T3 and SA60AT was statistically significant (all p-values ≤ 0.0115) for each visual acuity category (20/20 or better, 20/25 or better, 20/32 or better and 20/40 or better) in favor of Model SA60T3.
- The difference in cumulative UCDVA between Models SA60T4 and SA60AT was statistically significant (all p-values ≤ 0.0082) for each visual acuity category (20/25 or better, 20/32 or better and 20/40 or better) in favor of Model SA60T4, with the exception of the 20/20 or better category.
- The difference in cumulative UCDVA between Models SA60T5 and SA60AT was statistically significant (all p-values ≤ 0.0171) for each visual acuity category (20/20 or better, 20/25 or better, 20/32 or better and 20/40 or better) in favor of Model SA60T5.

**Best Spectacle Distance Corrected Visual Acuity (BSCDVA)**

A summary of best spectacle corrected distance visual acuity (BSCDVA) achieved at six months postoperatively (Form 5 visit) among subjects who did not have any visually significant preoperative pathology or macular degeneration at any time (Best Case) is presented in **Table 17A**. Visual acuity achieved by the overall subject population is shown in **Table 17C**. Control data are found for the same data sets in **Tables 17B and 17D**, respectively.

Of the first operative eyes implanted with a Model SA60TT and examined at six months postoperatively (Form 5 visit), 100.0% achieved a BSCDVA of 20/40 or better in the Best Case dataset. These rates exceed the FDA grid rates of 96.7%.

**Table 17A: BSCDVA by Age Category, Status at Form 5 - Lens Model SA60TT, Best Case**

Age Category	Sample size N	Acuity										20/40 or better	
		20/20 or better		20/25		20/32		20/40		Worse than 20/40			
		n	%	n	%	n	%	n	%	n	%	n	%
<60	29	27	93.1	1	3.4	1	3.4	0	0	0	0	29	100.0
60-69	51	42	82.4	7	13.7	2	3.9	0	0	0	0	51	100.0
70-79	73	57	78.1	13	17.8	3	4.1	0	0	0	0	73	100.0
≥80	20	14	70.0	4	20.0	1	5.0	1	5.0	0	0	20	100.0
Total	173	140	80.9	25	14.5	7	4.0	1	0.6	0	0	173	100.0

**Product: Clareon™ Toric Aspheric Hydrophobic Acrylic IOL  
Model: CNW0T3-CNW0T9**

Note: Text in gray is for informational purposes only

**Table 17B: BSCDVA by Age Category, Status at Form 5 - Lens Model SA60AT, Best Case**

Age Category	Sample size	Acuity										20/40 or better	
		20/20 or better		20/25		20/32		20/40		Worse than 20/40			
		N	n	%	n	%	n	%	n	%	n	%	n
<60	15	13	86.7	1	6.7	1	6.7	0	0	0	0	15	100.0
60-69	49	38	77.6	11	22.4	0	0	0	0	0	0	49	100.0
70-79	75	48	64.0	21	28.0	6	8.0	0	0	0	0	75	100.0
≥80	32	19	59.4	8	25.0	2	6.3	3	9.4	0	0	32	100.0
Total	171	118	69.0	41	24.0	9	5.3	3	1.8	0	0	171	100.0

Of the first operative eyes implanted with a Model SA60TT and examined at six months postoperatively (Form 5 visit), 100.0% achieved a BSCDVA of 20/40 or better in the All Implanted dataset. These rates exceed the FDA grid rates of 92.5%.

**Table 17C: BSCDVA by Age Category, Status at Form 5 - Lens Model SA60TT, All Implanted**

Age Category	Sample size	Acuity										20/40 or better	
		20/20 or better		20/25		20/32		20/40		Worse than 20/40			
		N	n	%	n	%	n	%	n	%	n	%	n
<60	33	30	90.9	2	6.1	1	3.0	0	0	0	0	33	100.0
60-69	56	47	83.9	7	12.5	2	3.6	0	0	0	0	56	100.0
70-79	90	72	80.0	15	16.7	3	3.3	0	0	0	0	90	100.0
≥80	32	22	68.8	5	15.6	4	12.5	1	3.1	0	0	32	100.0
Total	211	171	81.0	29	13.7	10	4.7	1	0.5	0	0	211	100.0

**Table 17D: BSCDVA by Age Category, Status at Form 5 - Lens Model SA60AT, All Implanted**

Age Category	Sample size	Acuity										20/40 or better	
		20/20 or better		20/25		20/32		20/40		Worse than 20/40			
		N	n	%	n	%	n	%	n	%	n	%	n
<60	15	13	86.7	1	6.7	1	6.7	0	0	0	0	15	100.0
60-69	54	41	75.9	12	22.2	1	1.9	0	0	0	0	54	100.0
70-79	91	59	64.8	22	24.2	10	11.0	0	0	0	0	91	100.0
≥80	49	28	57.1	13	26.5	2	4.1	3	6.1	3	6.1	46	93.9
Total	209	141	67.5	48	23.0	14	6.7	3	1.4	3	1.4	206	98.6

**Figures 4A–4C** show a summary of cumulative best corrected visual acuities for each Toric model compared to the control subjects in the same cylinder range for the All Implanted dataset.

**Product: Clareon™ Toric Aspheric Hydrophobic Acrylic IOL  
Model: CNW0T3-CNW0T9**

Note: Text in gray is for informational purposes only

**Figure 4A: Cumulative BSCDVA, Model SA60T3 vs. Control, Form 5, All Implanted**

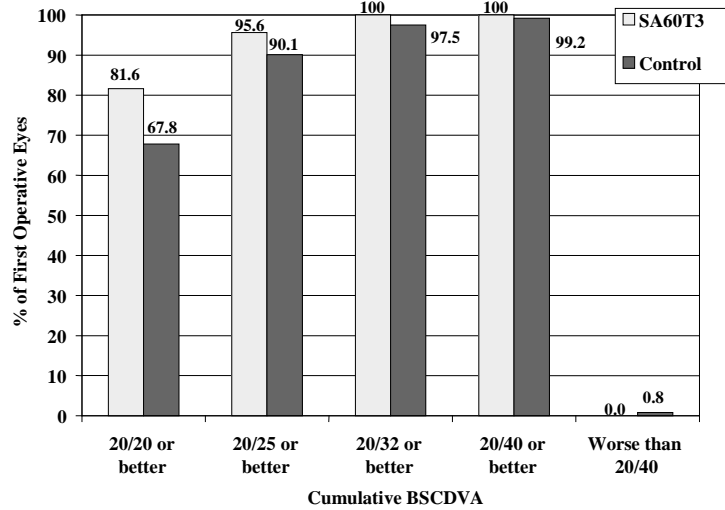

**Figure 4B: Cumulative BSCDVA, Model SA60T4 vs. Control, Form 5, All Implanted**

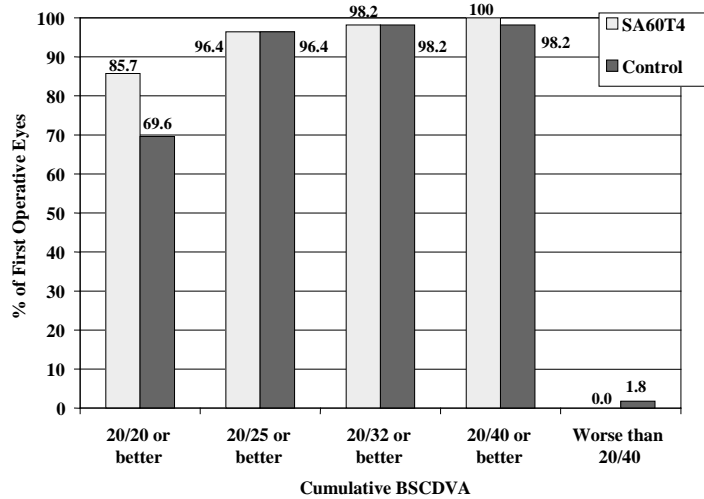

**Figure 4C: Cumulative BSCDVA, Model SA60T5 vs. Control, Form 5, All Implanted**

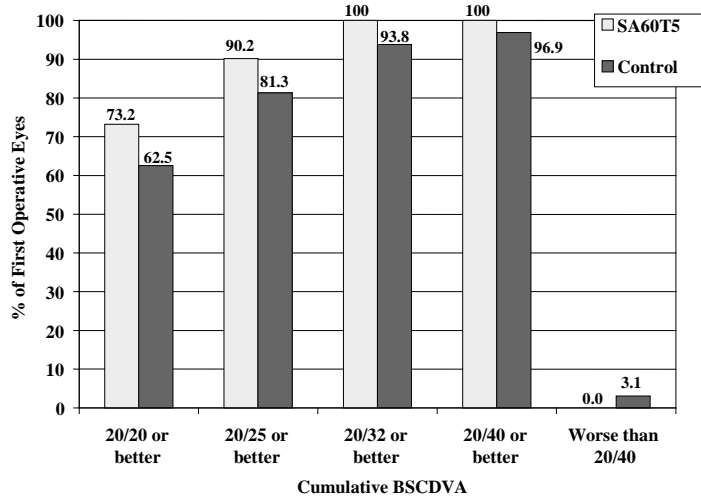

**Product: Clareon™ Toric Aspheric Hydrophobic Acrylic IOL  
Model: CNW0T3-CNW0T9**

Note: Text in gray is for informational purposes only

**Absolute Residual Refractive Cylinder**

Figures 5A-5C demonstrate that residual refractive cylinder values were statistically significantly lower among those subjects implanted with an AcrySof™ Toric IOL Model SA60T3, SA60T4, or SA60T5 when compared to the corresponding subjects implanted with the control Model SA60AT. Subjects implanted with an AcrySof™ Toric Model SA60T3 showed a 62.4% mean reduction in refractive cylinder from the preoperative visit (keratometric cylinder) as compared to the 10.8% mean reduction for subjects implanted with the concurrent control Model SA60AT. Subjects implanted with an AcrySof™ Toric IOL Model SA60T4 or SA60T5 showed similar results with a mean reduction in refractive cylinder of 54.8 % and 67.8%, respectively, as compared to subjects implanted with the concurrent control model who had a mean reduction in refractive cylinder of 22.1% and 27.7%, respectively. Each of the AcrySof™ Toric Lens Models SA60T3, SA60T4 and SA60T5 had at least a 3-fold increase in the likelihood of achieving residual refractive cylinder of 0.5 D or less as compared to the corresponding control model.

**Figure 5A: AcrySof™ Toric IOL: Absolute Residual Refractive Cylinder, Model SA60T3 vs. Control, 6 Month Visit (Form 5), All Implanted**

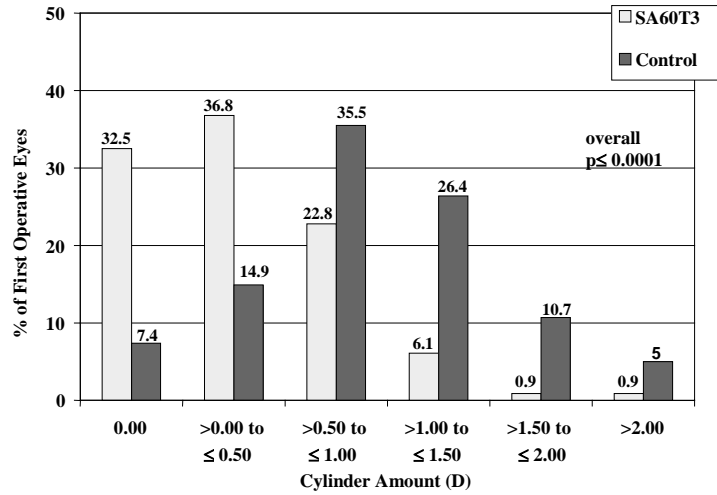

**Figure 5B: AcrySof™ Toric IOL: Absolute Residual Refractive Cylinder, Model SA60T4 vs. Control, 6 Month Visit (Form 5), All Implanted**

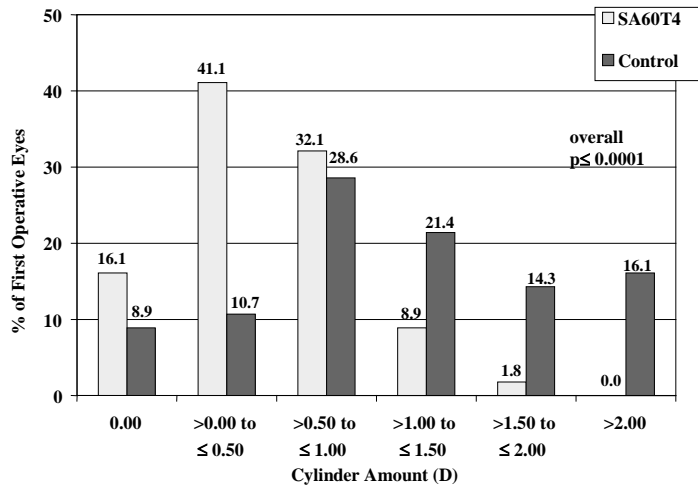

**Product: Clareon™ Toric Aspheric Hydrophobic Acrylic IOL  
Model: CNW0T3-CNW0T9**

Note: Text in gray is for informational purposes only

**Figure 5C: AcrySof™ Toric IOL: Absolute Residual Refractive Cylinder, Model SA60T5 vs. Control, 6 Month Visit (Form 5), All Implanted**

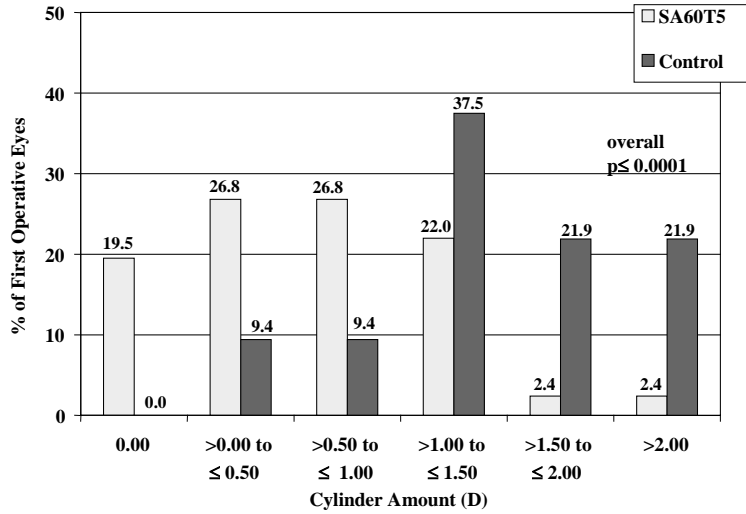

**Stability of Cylinder**

Subjects implanted with lens Model SA60TT exhibited stability of cylinder at Form 4 (3 months) with greater than 90% of all subjects changing less than or equal to 1.00 diopter at consecutive visits between Form 3 (one month) and Form 6 (twelve months) as described in **Tables 18A-18D**.

**Table 18A: AcrySof™ Toric IOL: Stability of Cylinder  
(Eyes that had 2 consecutive exams, but not necessarily every follow-up exam)**

Recommended Corneal Astigmatism Correction Ranges	Toric IOL Model	Magnitude of Vector Change in Cylinder	1 and 3 Months n/N,%	3 and 6 Months n/N,%	6 and 12 Months n/N,%
< 1.5 D	SA60T3	≤ 1.00 D	106/107,99.07%	101/105,96.19%	55/55,100.00%
		Mean Change	0.28	0.29	0.20
		SD	0.32	0.33	0.25
≥ 1.5 - < 2.0 D	SA60T4	≤ 1.00 D	54/56,96.43%	53/54,98.15%	25/27,92.59%
		Mean Change	0.40	0.27	0.46
		SD	0.35	0.22	0.45
≥ 2.0 D	SA60T5	≤ 1.00 D	40/45,88.89%	35/40,87.50%	27/30,90.00%
		Mean Change	0.43	0.42	0.41
		SD	0.44	0.45	0.38
Combined	SA60TT	≤ 1.00 D	200/208,96.15% (93.54,98.77)	189/199,94.97% (91.94,98.01)	107/112,95.54% (91.71,99.36)
		Mean Change	0.35	0.31	0.32
		SD	0.36	0.34	0.36
		95% CI	0.30,0.39	0.26,0.36	0.25,0.39

n/N,%,(%CI) are for percent with change between ± 1.00D

**Product: Clareon™ Toric Aspheric Hydrophobic Acrylic IOL  
Model: CNW0T3-CNW0T9**

Note: Text in gray is for informational purposes only

**Table 18B: AcrySof™ Toric IOL: Stability of Cylinder  
(Eyes that had every follow-up exam up to Form 6, 12 months)**

Recommended Corneal Astigmatism Correction Ranges	Toric IOL Model	Magnitude of Vector Change in Cylinder	1 and 3 Months n/N,%	3 and 6 Months n/N,%	6 and 12 Months n/N,%
< 1.5 D	SA60T3	≤ 1.00 D	34/34,100.00%	34/34,100.00%	34/34,100.00%
		Mean Change	0.25	0.24	0.21
		SD	0.23	0.22	0.24
≥ 1.5 - < 2.0 D	SA60T4	≤ 1.00 D	17/17,100.00%	16/17,94.12%	16/17,94.12%
		Mean Change	0.27	0.25	0.35
		SD	0.25	0.26	0.33
≥ 2.0 D	SA60T5	≤ 1.00 D	17/19,89.47%	15/19,78.95%	16/19,84.21%
		Mean Change	0.44	0.56	0.52
		SD	0.47	0.50	0.43
Combined	SA60TT	≤ 1.00 D	68/70,97.14% (93.23,100.00)	65/70,92.86% (86.82,98.90)	66/70,94.29% (88.84,99.73)
		Mean Change	0.31	0.33	0.33
		SD	0.32	0.35	0.34
		95% CI	0.23,0.38	0.24,0.41	0.25,0.41

n/N,%,(%CI) are for percent with change between ± 1.00D

**Table 18C: AcrySof™ Toric IOL: Stability of Absolute Cylinder  
(Eyes that had 2 consecutive exams, but not necessarily every follow-up exam)**

Recommended Corneal Astigmatism Correction Ranges	Toric IOL Model	Magnitude of Change in Absolute Cylinder	1 and 3 Months n/N,%	3 and 6 Months n/N,%	6 and 12 Months n/N,%
< 1.5 D	SA60T3	≤ 1.00 D	107/107,100.00%	104/105,99.05%	55/55,100.00%
		Mean Change	0.04	0.02	0.05
		SD	0.32	0.38	0.29
≥ 1.5 - < 2.0 D	SA60T4	≤ 1.00 D	54/56,96.43%	54/54,100.00%	27/27,100.00%
		Mean Change	0.18	0.05	-0.12
		SD	0.42	0.27	0.41
≥ 2.0 D	SA60T5	≤ 1.00 D	44/45,97.78%	37/40,92.50%	29/30,96.67%
		Mean Change	0.09	0.06	0.00
		SD	0.38	0.49	0.45
Combined	SA60TT	≤ 1.00 D	205/208,98.56% (96.93,100.00)	195/199,97.99% (96.04,99.94)	111/112,99.11% (97.36,100.00)
		Mean Change	0.09	0.03	-0.01
		SD	0.37	0.38	0.37
		95% CI	0.04,0.14	-0.02,0.09	-0.08,0.06

n/N,%,(%CI) are for percent with change between ± 1.00D



**Product: Clareon™ Toric Aspheric Hydrophobic Acrylic IOL  
Model: CNW0T3-CNW0T9**

Note: Text in gray is for informational purposes only

**Table 18D: AcrySof™ Toric IOL: Stability of Absolute Cylinder  
(Eyes that had every follow-up exam up to Form 6, 12 months)**

Recommended Corneal Astigmatism Correction Ranges	Toric IOL Model	Magnitude of Change in Absolute Cylinder	1 and 3 Months n/N,%	3 and 6 Months n/N,%	6 and 12 Months n/N,%
< 1.5 D	SA60T3	≤ 1.00 D	34/34,100.00%	34/34,100.00%	34/34,100.00%
		Mean Change	0.01	-0.01	0.07
		SD	0.28	0.31	0.28
≥ 1.5 - < 2.0 D	SA60T4	≤ 1.00 D	17/17,100.00%	17/17,100.00%	17/17,100.00%
		Mean Change	0.06	0.19	-0.04
		SD	0.30	0.21	0.42
≥ 2.0 D	SA60T5	≤ 1.00 D	18/19,94.74%	17/19,89.47%	18/19,94.74%
		Mean Change	0.17	0.05	0.01
		SD	0.45	0.54	0.55
Combined	SA60TT	≤ 1.00 D	69/70,98.57% (95.78,100.00)	68/70,97.14% (93.23,100.00)	69/70,98.57% (95.78,100.00)
		Mean Change	0.07	0.05	0.03
		SD	0.34	0.38	0.40
		95% CI	-0.01,0.15	-0.04,0.14	-0.07,0.12

n/N,%,(%CI) are for percent with change between ± 1.00D

**Adverse Events**

The incidence of cumulative adverse events for the Model SA60TT compared favorably to the FDA historical grid rates. Only the rates for retinal detachment/repair and surgical reintervention exceeded the FDA historical grid (**Table 19**). However, neither of these rates were statistically significant (p=0.5196 and p=0.1336, respectively). No occurrences of persistent adverse events were observed in any subjects implanted with the AcrySof™ Toric IOL.

**Table 19: AcrySof™ Toric IOL: Adverse Events Incidence Rates, First Eye – Safety**

Cumulative Adverse Events	Model SA60TT N=244		FDA Grid Rate
	N	%	%
Retinal Detachment/Repair	1	0.4	0.3
Surgical Reintervention	4**	1.6	0.8
IOL Reposition Due to Rotation	1	0.4	NA
IOL Replacement Due to Rotation	1	0.4	NA
Laser Treatment	2	0.8	NA
Paracentesis	1	0.4	NA

The incidence rates in this table are based upon the number of eyes with an event divided by the number of eyes implanted.

Cumulative adverse events are those events that have occurred at any time during the clinical study.

FDA Grid Rate = FDA Grid of Adverse Events with Posterior Chamber Intraocular Lens Historical Controls, FDA Intraocular Lens Guidance Document, Annex B (October 14, 1999)

\*\*There were 5 occurrences of surgical reintervention in 4 eyes for Model SA60TT first eye

The incidence of cumulative adverse events for the Model SA60TT also compared favorably to the concurrent control.

**Distance-Vision Spectacle Independence**

Spectacle independence was assessed in the study by direct subject responses obtained from a self-reported, binocular subject questionnaire. Since the AcrySof™ Toric IOL study was completed in 2005, the questionnaire utilized was not developed using the US FDA guidance document “*Patient-Reported Outcomes Measures: Use in Medical Product Development to Support Labeling Claims*” dated December 2009.

Statistically significantly more Model SA60TT subjects reported postoperative distance-vision spectacle independence compared to Model SA60AT subjects (59.9% versus 37.7%, respectively) when unilaterally implanted. Distance-vision spectacle independence was defined as the percentage of subjects who selected the “none of the time” response for distance-vision frequency-of-spectacle-wear. Spectacle dependence was defined as subjects indicating any reliance on

**Product: Clareon™ Toric Aspheric Hydrophobic Acrylic IOL  
Model: CNW0T3-CNW0T9**

Note: Text in gray is for informational purposes only

glasses for distance-vision and represents the summation of the “some of the time”, “half of the time”, “most of the time” and “all of the time” frequency-of-spectacle-wear responses. Consequently, fewer Model SA60TT subjects were spectacle dependent at 40.1% compared to 62.3% of the Model SA60AT subjects. **Figure 6** illustrates the distance-vision frequency-of-spectacle-wear distributions between Model SA60TT and Model SA60AT groups. Implantation of an AcrySof™ Toric Intraocular lens in astigmatic subjects provides significantly improved distance-vision spectacle independence relative to a conventional monofocal IOL.

**Figure 6: Distance-Vision Spectacle Independence: Frequency of Spectacle Wear, Form 5, All Implanted**

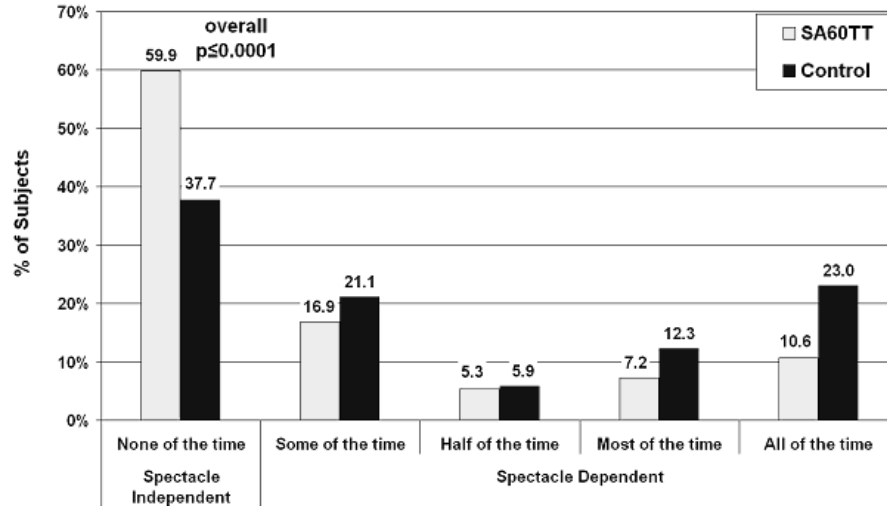

**3. AcrySof™ TORIC HIGH CYLINDER POWER INTRAOCULAR LENS CLINICAL STUDY**

**Overview of Clinical Study**

A clinical study was conducted to investigate the rates of spatial distortions related to axial misalignment of the AcrySof™ Toric Posterior Chamber High Cylinder Power Intraocular Lenses (Models SN60T6-SN60T9). The cylinder power at the IOL plane and corneal plane and the recommended correction ranges are shown in **Table 20**.

**Table 20: AcrySof™ Toric High Cylinder Power IOL:  
High Cylinder Powers and Recommended Correction Ranges**

Model	Cylinder Power		Toric Calculator Recommended Corneal Astigmatism Correction Ranges
	at IOL plane	at corneal plane	
SN60T6	3.75	2.57	2.57 – 3.07 D
SN60T7	4.50	3.08	3.08 – 3.59 D
SN60T8	5.25	3.60	3.60 – 4.10 D
SN60T9	6.00	4.11	4.11 D and up

These recommended corneal astigmatism correction ranges are based on the preoperative corneal astigmatism and the predicted effect of surgically induced astigmatism. To obtain the IOL cylindrical powers and the orientation of the surgical placement of the axes, for each operative eye the preoperative keratometry values and axes, IOL spherical power (as determined by the surgeon’s preferred formula), and the surgeon’s estimated surgically induced astigmatism (SIA) at the standard temporal incision location are entered into Alcon’s proprietary web-based AcrySof™ Toric IOL calculator. The combination of these parameters are used in the Alcon provided software to select the appropriate Toric IOL model and recommended axis of placement. As such, the recommended range of corneal astigmatism to be corrected while not identical, is directly related to, the preoperative keratometric cylinder. The results achieved by the patients followed to six months (Visit 5A) postoperatively demonstrate that the AcrySof™ Toric High Cylinder Power IOL models are safe and effective for the visual correction of aphakia. The following clinical results illustrate the AcrySof™ Toric High Cylinder Power IOL’s effectiveness in significantly reducing pre-existing corneal astigmatism and the IOL’s excellent rotational stability following implantation in the capsular bag.

**Product: Clareon™ Toric Aspheric Hydrophobic Acrylic IOL  
Model: CNW0T3-CNW0T9**

Note: Text in gray is for informational purposes only

**Subject Population**

This study focused on the highest cylinder power IOL Model SN60T9; however, due to the rarity of this level of astigmatism IOL Model SN60T8 was included to expand the inclusion criteria for the second eye. The subject population implanted with an IOL Model SN60T9 in the first operative eye consists of 80% (12/15) females and 20% (3/15) males. For the fellow eye, 3 subjects were implanted with IOL Model SN60T9, while 12 were implanted with IOL Model SN60T8. All 15 (100%) of the implanted subjects were white. The mean age for the population was 67 years old (range of 43 to 82 years) at the time of surgery.

**Absolute Residual Refractive Cylinder**

Refractive cylinder six months postoperatively was reduced for all subjects implanted with either an AcrySof™ Toric IOL Model SN60T8 or SN60T9 compared to preoperative baseline. Results show a statistically significant reduction (p-value <0.0001) in residual refractive cylinder in eyes implanted with IOL Model SN60T9 [85.7% in first eyes (n=15), 87.4% in second eyes (n=3) and IOL Model SN60T8 [87.3% (n=12)].

**Uncorrected Distance Visual Acuity**

All subjects implanted bilaterally with the AcrySof™ Toric IOL Models SN60T8 or SN60T9 achieved improved binocular uncorrected distance visual acuity six months postoperatively. **Figure 7** demonstrates that 60% of subjects achieved 20/20 or better binocular uncorrected distance visual acuity compared to 30% for monocular eyes, while 93% of subjects achieved 20/40 or better binocular uncorrected distance visual acuity compared to 90% of monocular eyes. Less than 10% of subjects had monocular or binocular uncorrected distance visual acuity worse than 20/40 six months postoperatively.

**Figure 7: Cumulative UCDVA Monocular versus Binocular**

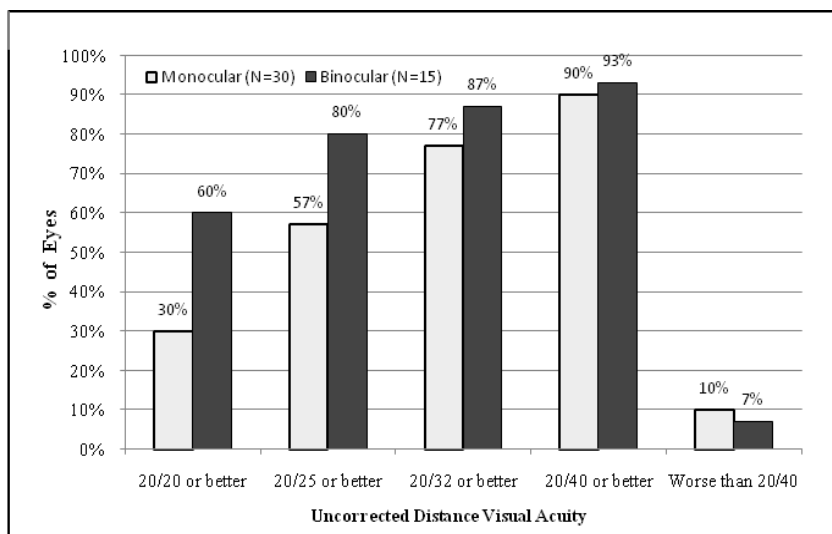

**Bilateral Distance-Vision Spectacle Independence**

Spectacle independence was assessed in the study by direct subject responses obtained from a self-reported, binocular subject questionnaire. Since the AcrySof™ Toric High Cylinder Power IOL study was initiated in August 2009, the questionnaire utilized was not developed using the US FDA guidance document “*Patient-Reported Outcomes Measures: Use in Medical Product Development to Support Labeling Claims*” dated December 2009.

Preoperatively all subjects were spectacle dependent, either all the time (92.9%) or some of the time (7.1%). Six months postoperatively, 71.4% of subjects were spectacle independent (**Figure 8**).

**Figure 8: Bilateral Distance Vision Spectacle Independence  
Frequency of Spectacle Wear Visit 0 (PreOp) versus Visit 5A (Final Visit)**

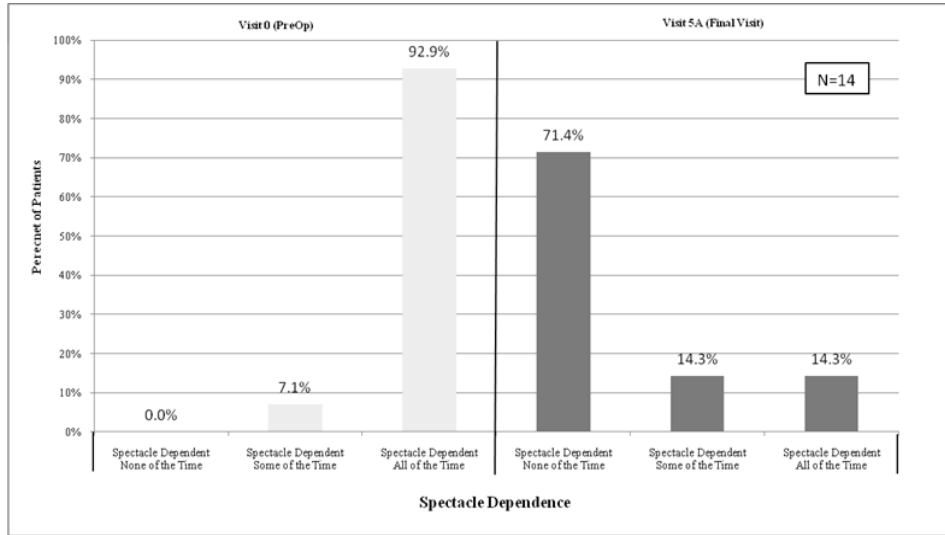

**Rate of Spatial Distortions**

The rate of spatial distortions was assessed in the study by direct subject responses obtained from a self-reported, binocular subject questionnaire. Since the AcrySof™ Toric High Cylinder Power IOL study was initiated in August 2009, the questionnaire utilized was not developed using the US FDA guidance document “Patient-Reported Outcomes Measures: Use in Medical Product Development to Support Labeling Claims” dated December 2009.

A visual distortion questionnaire was administered preoperatively (Visit 0) and at six months postoperatively (Visit 5A) to evaluate the rate of spatial distortions of the AcrySof™ Toric IOL Models SN60T8 and SN60T9. The overall rate of spatial distortions decreased postoperatively (Table 21A).

**Table 21A: AcrySof™ Toric High Cylinder Power IOL: Visual Distortion Questionnaire Results by Visit**

During the past 4 weeks, have you had		PreOp (N = 14)		Final Visit (N = 14)	
		n	%	n	%
1) ...trouble with things appearing distorted?	No	3	21.4	12	85.7
	Yes	11	78.6	2 <sup>a,b</sup>	14.3
2) ...trouble with flat surfaces (like floors) appearing curved?	No	12	85.7	13	92.9
	Yes	2	14.3	1 <sup>c</sup>	7.1
3) ...trouble with straight lines (like door or window frames) appearing tilted?	No	10	71.4	14	100
	Yes	4	28.6	0	0.0
4) ...trouble with feeling sick to your stomach due to distortion of your vision?	No	14	100	14	100
	Yes	0	0.0	0	0.0

<sup>a</sup>Reported with or without glasses at Preop and Final Visit.

<sup>b</sup>Reported with or without glasses at Preop but only with glasses (progressive lenses) at Final Visit.

<sup>c</sup>Same subject as in (b). Reported only with glasses (progressive lenses) at Final Visit. Not reported at Preop.

Based on these questions spatial distortions associated with high pre-existing corneal astigmatism may not completely resolve postoperatively. Two subjects at Visit 5A continued to report “trouble with things appearing distorted” versus 11 subjects preoperatively. One of these subjects had “trouble with flat surfaces appearing curved,” which was noted only postoperatively, but no longer experienced the preoperative visual phenomena of straight lines appearing tilted. Neither subject had IOL misalignment requiring secondary surgical intervention to address problems of spatial distortion. There were no reports of subjects feeling sick to their stomachs due to distortion of vision.

Responses to visual distortion sub-questions related to spectacle wear, frequency of experiencing distortion, and degree of bother are presented in Tables 21B through 21D.

**Product: Clareon™ Toric Aspheric Hydrophobic Acrylic IOL  
Model: CNW0T3-CNW0T9**

Note: Text in gray is for informational purposes only

**Table 21B: AcrySof™ Toric High Cylinder Power IOL:  
Visual Distortion Questionnaire Results – Trouble with Things Appearing Distorted**

1) For subjects who had trouble with things appearing distorted in the last 4 weeks:		PreOp (N = 11)		Final Visit (N = 2)	
		n	%	n	%
Do you notice this only when you wear your glasses?	No	10	90.9	1	50.0
	Yes	1	9.1	1	50.0
How often have you noticed this?	Rarely	2	18.2	0	0.0
	Sometimes	2	18.2	0	0.0
	Frequently	3	27.3	1	50.0
	All the time	4	36.4	1	50.0
How much does it bother you?	None	1	9.1	1	50.0
	A Little	4	36.4	0	0.0
	A Lot	6	54.5	1	50.0

**Table 21C: AcrySof™ Toric High Cylinder Power IOL:  
Visual Distortion Questionnaire Results – Trouble with Flat Surfaces Appearing Curved**

2) For subjects who had trouble with flat surfaces (like floors) appearing curved in the last 4 weeks:		PreOp (N = 2)		Final Visit (N = 1)	
		n	%	n	%
Do you notice this only when you wear your glasses?	No	2	100	0	0.0
	Yes	0	0.0	1	100
How often have you noticed this?	Rarely	0	0.0	0	0.0
	Sometimes	0	0.0	0	0.0
	Frequently	1	50.0	1	100
	All the time	1	50.0	0	0.0
How much does it bother you?	None	0	0.0	0	0.0
	A Little	0	0.0	0	0.0
	A Lot	2	100	1	100

**Table 21D: AcrySof™ Toric High Cylinder Power IOL:  
Visual Distortion Questionnaire Results – Trouble with Straight Lines Appearing Tilted**

3) For subjects who had trouble with straight lines (like door or window frames) appearing tilted in the last 4 weeks:		PreOp (N = 4)		Final Visit (N = 0)	
		n	%	n	%
Do you notice this only when you wear your glasses?	No	3	75.0	0	0.0
	Yes	1	25.0	0	0.0
How often have you noticed this?	Rarely	0	0.0	0	0.0
	Sometimes	2	50.0	0	0.0
	Frequently	0	0.0	0	0.0
	All the time	2	50.0	0	0.0
How much does it bother you?	None	0	0.0	0	0.0
	A Little	1	25.0	0	0.0
	A Lot	3	75.0	0	0.0

**Adverse Events**

During the study, 1 of 15 subjects underwent a secondary surgical intervention in the first eye to resolve residual refractive cylinder due to an error in preoperative keratometry. One week postoperatively, the IOL was repositioned. At six months postoperatively the subject was satisfied with uncorrected distance vision and did not experience any spatial distortion after IOL repositioning. No other serious adverse events were reported in the study.

















**Product: Clareon™ Toric Aspheric Hydrophobic Acrylic IOL  
Model: CNW0T3-CNW0T9**

Note: Text in gray is for informational purposes only

**REFERENCES**

- Abulafia A, Barrett GD, Kleinmann G, Ofir S, Levy A, Marcovich AL, *et al.* Prediction of refractive outcome with toric intraocular lens implantation. *J Cataract Refractive Surgery.* 2015; 41:936–944.
- Abulafia A, Hill WE, Franchina M, Barrett GD. Comparison of methods to predict residual astigmatism after intraocular lens implantation. *J Refractive Surgery.* 2015b; 31(10):699-706.
- Boettner, E.A. and Wolter, J.R. Transmission of the ocular media. *Invest. Ophthalmol.* 1962;1:776-83.
- Haigis W. ULIB - User group for Laser Interference Biometry. Updated 2014 Jul 17; cited 2015 Mar 13. Available at: <http://ocusoft.de/ulib/>.
- Hoffer KJ. The Hoffer Q formula: a comparison of theoretic and regression formulas. *J Cataract Refract Surg.* 1993;19(6):700-12.
- Holladay JT. Standardizing constants for ultrasonic biometry, keratometry, and intraocular lens power calculations. *J Cataract Refract Surg.* 1997;23(9):1356-70.
- Ma JJ, Tseng SS. Simple method for accurate alignment in toric phakic and aphakic intraocular lens implantation. *J Cataract Refract Surg.* 2008;34:1631-6.
- Olsen T. Calculation of intraocular lens power: a review. *Acta Ophthalmol Scand.* 2007;85(5):472-85.
- Retzlaff JA, Sanders DR, Kraff M. *Lens Implant Power Calculation.* 3rd ed. Thorofare (NJ): Slack, Inc.; 1990.

**STAND ALONE SYMBOLS FROM ISO 7000/ISO 7001\* USED ON LABELING  
(ISO 7000 Title: Graphical Symbols for Use on Equipment)  
(\*ISO 7001 Title: Graphical symbols – Public information symbols)**

Symbol	Reference Number from ISO 7000 / ISO 7001*	Symbol Title / Explanatory Text
	1051	Do not re-use
	2608	Do not re-sterilize
	2607	Use-by date
	2501	Sterilized using ethylene oxide
	2498	Serial number
	2493	Catalogue number
	0434A	Caution
	3082	Manufacturer
	0533	Upper limit of temperature
	1641	Consult instructions for use
	3500	Electronic instructions for use
	2606	Do not use if package has been damaged
	2497	Date of Manufacture
	3079	Open Here
	3010	RFID tag, general
	5662	Date
	PI PF 002*	Hospital

\*This symbol is the only one from ISO 7001 in the table above.

**Product: Clareon™ Toric Aspheric Hydrophobic Acrylic IOL  
Model: CNW0T3-CNW0T9**

Note: Text in gray is for informational purposes only

**ABBREVIATIONS or SYMBOLS USED ON LABELING**

Symbol	Symbol Title / Explanatory Text
	Medical device
	Single sterile barrier system
IOL	Intraocular lens
OVD	Ophthalmic viscosurgical device
	UV and Blue Light Filter
	Posterior chamber IOL
UV	Ultraviolet
D	Diopter
$\varnothing_B$	Body diameter (Optic diameter)
$\varnothing_T$	Overall diameter (Overall length)
L	Left
R	Right
CYL	Cylinder Add Power
PWR	Spherical Equivalent Power
	D-size nozzle for MONARCH™ cartridge*
	C-size nozzle for MONARCH™ cartridge*
	Not made with natural rubber latex
	Does not contain PHT (phthalates)
	MR Safe
	Caution: Federal (USA) Law restricts this device to sale by or on the order of a physician
	Authorized Representative in the European Community
*The recommendation shown on the labeling is for the smallest qualified cartridge nozzle size per diopter. For all qualified combinations of products, please review <b>Table 3</b> .	



Alcon Laboratories, Inc.  
6201 South Freeway  
Fort Worth, Texas 76134-2099 USA

† Trademarks are the property of their respective owners.

**ALCON** (current approved logo)

<Insert copyright>