



SIMDA Co., Ltd.  
Young Woo Cha  
Regulatory Affairs Manager  
156-4, Gamjeon-dong  
Busan, Sasang-gu  
REPUBLIC OF KOREA

May 24, 2023

Re: K223663  
Trade/Device Name: SIMDA Abutment  
Regulation Number: 21 CFR 872.3630  
Regulation Name: Endosseous Dental Implant Abutment  
Regulatory Class: Class II  
Product Code: NHA  
Dated: April 26, 2023  
Received: April 26, 2023

Dear Young Woo Cha:

We have reviewed your Section 510(k) premarket notification of intent to market the device referenced above and have determined the device is substantially equivalent (for the indications for use stated in the enclosure) to legally marketed predicate devices marketed in interstate commerce prior to May 28, 1976, the enactment date of the Medical Device Amendments, or to devices that have been reclassified in accordance with the provisions of the Federal Food, Drug, and Cosmetic Act (Act) that do not require approval of a premarket approval application (PMA). You may, therefore, market the device, subject to the general controls provisions of the Act. Although this letter refers to your product as a device, please be aware that some cleared products may instead be combination products. The 510(k) Premarket Notification Database located at <https://www.accessdata.fda.gov/scripts/cdrh/cfdocs/cfpmn/pmn.cfm> identifies combination product submissions. The general controls provisions of the Act include requirements for annual registration, listing of devices, good manufacturing practice, labeling, and prohibitions against misbranding and adulteration. Please note: CDRH does not evaluate information related to contract liability warranties. We remind you, however, that device labeling must be truthful and not misleading.

If your device is classified (see above) into either class II (Special Controls) or class III (PMA), it may be subject to additional controls. Existing major regulations affecting your device can be found in the Code of Federal Regulations, Title 21, Parts 800 to 898. In addition, FDA may publish further announcements concerning your device in the Federal Register.

Please be advised that FDA's issuance of a substantial equivalence determination does not mean that FDA has made a determination that your device complies with other requirements of the Act or any Federal statutes and regulations administered by other Federal agencies. You must comply with all the Act's requirements, including, but not limited to: registration and listing (21 CFR Part 807); labeling (21 CFR Part 801); medical device reporting (reporting of medical device-related adverse events) (21 CFR 803) for devices or postmarketing safety reporting (21 CFR 4, Subpart B) for combination products (see <https://www.fda.gov/combination-products/guidance-regulatory-information/postmarketing-safety-reporting-combination-products>); good manufacturing practice requirements as set forth in the quality systems (QS) regulation (21 CFR Part 820) for devices or current good manufacturing practices (21 CFR 4, Subpart A) for combination products; and, if applicable, the electronic product radiation control provisions (Sections 531-542 of the Act); 21 CFR 1000-1050.

Also, please note the regulation entitled, "Misbranding by reference to premarket notification" (21 CFR Part 807.97). For questions regarding the reporting of adverse events under the MDR regulation (21 CFR Part 803), please go to <https://www.fda.gov/medical-devices/medical-device-safety/medical-device-reporting-mdr-how-report-medical-device-problems>.

For comprehensive regulatory information about medical devices and radiation-emitting products, including information about labeling regulations, please see Device Advice (<https://www.fda.gov/medical-devices/device-advice-comprehensive-regulatory-assistance>) and CDRH Learn (<https://www.fda.gov/training-and-continuing-education/cdrh-learn>). Additionally, you may contact the Division of Industry and Consumer Education (DICE) to ask a question about a specific regulatory topic. See the DICE website (<https://www.fda.gov/medical-devices/device-advice-comprehensive-regulatory-assistance/contact-us-division-industry-and-consumer-education-dice>) for more information or contact DICE by email ([DICE@fda.hhs.gov](mailto:DICE@fda.hhs.gov)) or phone (1-800-638-2041 or 301-796-7100).

Sincerely,

**Andrew I. Steen -S**

Andrew I. Steen  
Assistant Director  
DHT1B: Division of Dental and ENT Devices  
OHT1: Office of Ophthalmic, Anesthesia,  
Respiratory, ENT and Dental Devices  
Office of Product Evaluation and Quality  
Center for Devices and Radiological Health

Enclosure

## Indications for Use

510(k) Number (if known)

K223663

Device Name

SIMDA Abutments

Indications for Use (Describe)

SIMDA Abutments are intended for use with dental implants as a support for single or multiple tooth prostheses in the maxilla or mandible of a partially or fully edentulous patient.

It is compatible with the following systems:

Compatible System	Implant Body Diameter(mm)	Implant Platform
Osstem TS (K121995)	3.5, 3.75	Mini
	3.75, 3.77, 4.2, 4.25, 4.4, 4.6, 4.63, 4.65, 4.9, 5.05, 5.08, 5.1	Regular
Straumann Bone Level (only the Roxolid® implants from K140878)	3.3	NC
	4.1, 4.8	RC

All digitally designed abutments for use with SIMDA Abutments are intended to be sent to a SIMDA validated milling center for manufacture.

Type of Use (Select one or both, as applicable)

Prescription Use (Part 21 CFR 801 Subpart D)

Over-The-Counter Use (21 CFR 801 Subpart C)

**CONTINUE ON A SEPARATE PAGE IF NEEDED.**

This section applies only to requirements of the Paperwork Reduction Act of 1995.

**\*DO NOT SEND YOUR COMPLETED FORM TO THE PRA STAFF EMAIL ADDRESS BELOW.\***

The burden time for this collection of information is estimated to average 79 hours per response, including the time to review instructions, search existing data sources, gather and maintain the data needed and complete and review the collection of information. Send comments regarding this burden estimate or any other aspect of this information collection, including suggestions for reducing this burden, to:

Department of Health and Human Services  
Food and Drug Administration  
Office of Chief Information Officer  
Paperwork Reduction Act (PRA) Staff  
PRAStaff@fda.hhs.gov

*"An agency may not conduct or sponsor, and a person is not required to respond to, a collection of information unless it displays a currently valid OMB number."*

## K 223663 510(k) Summary

### Applicant

Name: SIMDA Co., Ltd.  
Address: 156-4, Gamjeon-dong, Sasang-gu, Busan, South Korea  
Phone: +82 70 4256 2855  
Contact: Young Woo, Cha  
Email: Email: chassi0406@gmail.com  
Date Prepared: 05/23/2023

### Subject Device

Trade Name: SIMDA Abutment  
Common Name: Dental implant abutment  
Classification Name: Endosseous dental implant abutment  
Product Code: NHA  
Panel: Dental  
Regulation Number: 21 CFR 872.3630  
Device Class: Class II

### Primary Predicate

Trade Name: TiGEN Abutment, ZrGEN Abutment and Scan Healing  
Common Name: Abutment (K220562)  
Classification Name: Endosseous dental implant abutment Abutment  
Product Code: NHA  
Panel: Dental  
Regulation Number: 21 CFR 872.3630  
Device Class: Class II

### Reference Device

Trade Name: OSSTEM TS Fixture System, OSSTEM Implant Co., Ltd.  
(K121995)  
Common Name: Dental implant abutment  
Classification Name: Endosseous dental implant abutment  
Product Code: DZE, NHA  
Panel: Dental  
Regulation Number: 21 CFR 872.3640  
Device Class: Class II

# SIMDA

Trade Name: Straumann® Bone Level Tapered Implants (K140878)

Common Name: Dental implant abutment  
Classification Name: Endosseous dental implant abutment  
Product Code: NHA  
Panel: Dental  
Regulation Number: 21 CFR 872.3630  
Device Class: Class II

Trade Name: DD Solid Connect® CAD/CAM Abutments Abutment  
Common Name: (K191111)  
Classification Name: Endosseous dental implant abutment Abutment

Product Code: NHA  
Panel: Dental  
Regulation Number: 21 CFR 872.3630  
Device Class: Class II

## Device Description

SIMDA Abutment is made of titanium alloy (Ti-6Al-4V ELI, ASTM F136) intended for use as an aid in prosthetic restoration. It consists of Pre-Milled Blank and Ti-Base abutment. It has a pre-manufactured connection interface that fits directly to an endosseous dental implant.

Pre-Milled Blank Design Limitation for Patient-specific abutment:

Design parameter (Patient-specific abutment)	Subject System Design Limit
Minimum and Maximum Gingival (Cuff) Height	0.5~5mm
Minimum and Maximum diameter at abutment/implant interface	Ø4.0~Ø8.0
Minimum and Maximum length of abutment	4.5~13mm
Minimum and Maximum length of abutment post (length above the abutment collar/gingival height)	4~8mm
Minimum wall thickness at abutment/implant interface	0.4mm
Minimum and Maximum abutment angle	0~25°

Ti Base consists of a two-piece abutment, where the titanium base is a pre-manufactured abutment that will be used to support a CAD/CAM-designed zirconia superstructure (the second part of the two-piece abutment) that composes the final abutment.

Pre-Milled Blank and Ti Base are provided non-sterile therefore must be sterilized after the cementation of the patient-specified superstructure.

### Raw material blanks

- InCoris Zi (ZrO2) by Sirona Dental Systems GmbH, L size blanks, cleared under K123664.

### Cement

- RelyX Unicem 2Automix by 3M ESPE, cleared under K100756.

Design Limitation for Zirconia superstructure:

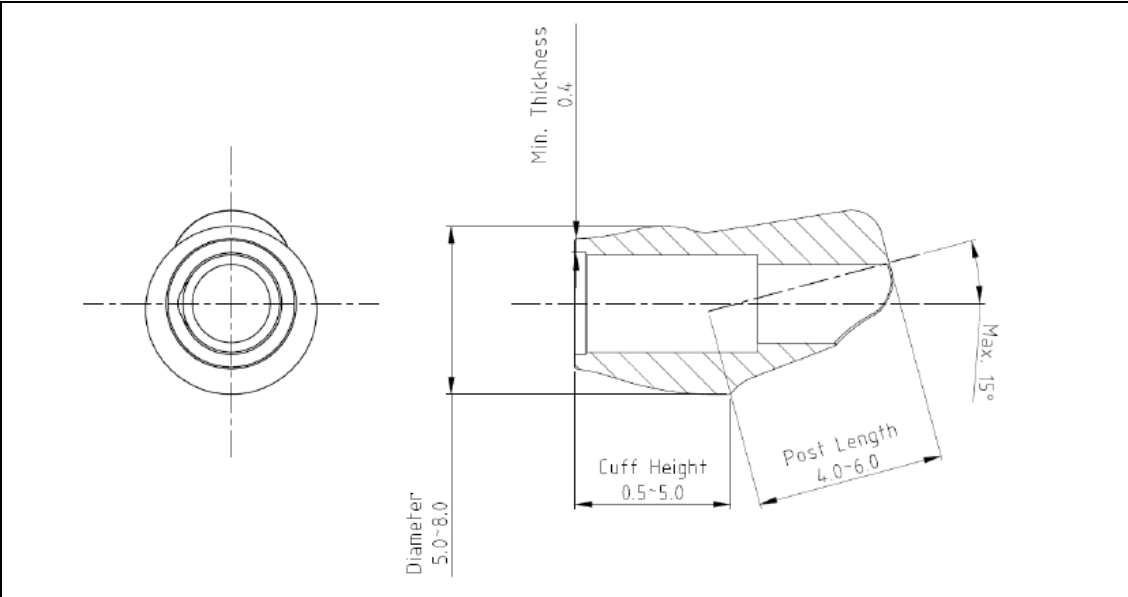

Design Parameter	Limit (Min.~Max.)
Minimum and Maximum abutment angle	0~15
Minimum and Maximum Gingival (Cuff) Height	0.5~5.0
Minimum and Maximum length of abutment post (length above the abutment collar/gingival height)	4.0~6.0
Minimum and Maximum diameter at abutment/implant interface	5.0~8.0
Minimum wall thickness at abutment/implant interface	0.4

SIMDA Abutment is a device that can only be sold, distributed, or used upon the order of an authorized healthcare provider, generally referred to as prescription (Rx) devices.

## Indication for Use

SIMDA Abutments are intended for use with dental implants as a support for single or multiple tooth prostheses in the maxilla or mandible of a partially or fully edentulous patient.

It is compatible with the following systems:

Compatible System	Implant Body Diameter(mm)	Implant Platform
Osstem TS (K121995)	3.5, 3.75	Mini
	3.75, 3.77, 4.2, 4.25, 4.4, 4.6, 4.63, 4.65, 4.9, 5.05, 5.08, 5.1	Regular
Straumann Bone Level (only the Roxolid® implants from K140878)	3.3	NC
	4.1, 4.8	RC

All digitally designed abutments for use with SIMDA Abutments are intended to be sent to a SMIDA validated milling center for manufacture.

## Summary of Technological Characteristics

The subject device and the primary predicate have the same intended use, similar technological characteristics, and are made of the same materials. The subject device and the primary predicate encompass the same range of physical dimensions, are packaged in similar materials, and are to be sterilized using similar methods. The data included in this submission demonstrate substantial equivalence to the primary predicate listed above.



## Non-clinical Testing

### MR Environment Condition

Non-clinical worst-case MRI review was performed to evaluate the metallic SIMDA abutment in the MRI environment using scientific rationale and published literature (e.g., Woods, Terry O., Jana G. Delfino, and Sunder Rajan. “Assessment of Magnetically Induced Displacement Force and Torque on Metal Alloys Used in Medical Devices.” *Journal of Testing and Evaluation* 49.2 (2019): 783-795), based on the entire system including all variations (all compatible implant bodies, dental abutments, and fixation screws) and material composition. Rationale addressed parameters per the FDA guidance “Testing and Labeling Medical Devices for Safety in the Magnetic Resonance (MR) Environment,” including magnetically induced displacement force and torque.

Non-clinical testing data submitted, referenced, or relied upon to demonstrate substantial equivalence included:

- Fatigue testing followed ISO 14801 and the FDA special controls guidance document.
- End User Steam Sterilization Test according to ISO 17665-1:2006, 17665-2:2009 and ANSI/AAMI ST79:2010.
- Biocompatibility tests according to ISO 10993-1:2009, ISO 10993-5:2009, and ISO 10993-10:2010.

Non-clinical test data was used to evaluate the proposed device’s substantial equivalence compared to the primary predicate. The results of the above tests have demonstrated the substantial equivalence with the primary predicate.

Non-clinical testing was conducted in accordance with FDA Guidance “Class II Special Controls Guidance Document: Root-form Endosseous Dental Implants and Endosseous Dental Implant Abutments”, and it consisted of testing finished assembled implant/abutment systems of the worst-case scenarios through fatigue testing.

Dimensional analysis and reverse engineering of critical features of critical features and tolerances of the implant-to-abutment connection platform were performed on the OEM implant body, the OEM abutment, and the OEM abutment screw. Cross sectional images were provided to demonstrate substantially equivalent compatibility. The testing aided implant to abutment compatibility and has established substantial equivalency of the proposed device with the predicate devices.

Clinical testing was not necessary to establish substantial equivalency of the device.

## Primary Predicate / Reference devices:

The subject device is substantially equivalent to the following primary predicate and reference devices:

- Primary Predicate
  - TiGEN Abutment, ZrGEN Abutment and Scan Healing Abutment (K220562)
- Reference devices
  - OSSTEM TS Fixture System (K121995)
  - Straumann® Tapered Implant System (K140878)
  - DD Solid Connect® CAD/CAM Abutments(K191111)

## Comparison between Primary predicates

### Pre-Milled Blank

Feature	Proposed Device SIMDA Abutment	Primary predicate TiGEN Abutment	SE discussion													
<b>Applicant</b>	SIMDA Co., Ltd.	MegaGen Co., Ltd.	=													
<b>Part Name</b>	Pre-Milled Blank	TiGEN Abutment, ZrGEN Abutment and Scan Healing Abutment	=													
<b>510(K) No.</b>	K223663	K220562	=													
<b>Classification Name</b>	Endosseous Dental Implant Abutments (872.3630)	Endosseous Dental Implant Abutments (872.3630)	Identical													
<b>Product Code</b>	NHA	NHA	Identical													
<b>Screw and Abutment Material</b>	Ti-6Al-4V ELI (ASTM F136)	Ti-6Al-4V ELI (ASTM F136)	Identical													
<b>Indications For Use</b>	<p>SIMDA Abutments are intended for use with dental implants as a support for single or multiple tooth prostheses in the maxilla or mandible of a partially or fully edentulous patient.</p> <p>It is compatible with the following systems:</p> <table border="1" data-bbox="289 1528 722 1696"> <thead> <tr> <th>Compatible System</th> <th>Implant Body Diameter(mm)</th> <th>Implant Platform</th> </tr> </thead> <tbody> <tr> <td rowspan="2">Osstem TS (K121995)</td> <td>3.5, 3.75</td> <td>Mini</td> </tr> <tr> <td>3.75, 3.77, 4.2, 4.25, 4.4, 4.6, 4.63, 4.65, 4.9, 5.05, 5.08, 5.1</td> <td>Regular</td> </tr> <tr> <td rowspan="2">Straumann Bone Level (only the Roxolid® implants from K140878)</td> <td>3.3</td> <td>NC</td> </tr> <tr> <td>4.1, 4.8</td> <td>RC</td> </tr> </tbody> </table> <p>All digitally designed abutments for use with SIMDA Abutments are intended to be sent to a SIMDA validated milling center for manufacture.</p>	Compatible System	Implant Body Diameter(mm)	Implant Platform	Osstem TS (K121995)	3.5, 3.75	Mini	3.75, 3.77, 4.2, 4.25, 4.4, 4.6, 4.63, 4.65, 4.9, 5.05, 5.08, 5.1	Regular	Straumann Bone Level (only the Roxolid® implants from K140878)	3.3	NC	4.1, 4.8	RC	<p>The TiGEN Abutment, ZrGEN Abutment and Scan Healing Abutment are intended for use on endosseous dental implants in the edentulous or partially edentulous maxilla or mandible, as an aid in prosthetic rehabilitation. For TiGEN Abutment and ZrGEN Abutment, all digitally designed abutments for use with TiGEN Abutment and ZrGEN Abutment are intended to be sent to a MegaGen-validated milling center for manufacture.</p>	<p>The subject device is substantially equivalent in indications and design principles to the primary predicate device listed above. Provided tables are comparing the Indications for Use Statements and the technological characteristics of the subject device, the primary predicate device. The Indications for Use Statement (IFUS) for the subject device is substantially equivalent in intended use to the primary predicate device. All are intended for use with endosseous dental implants in the maxilla and mandible to provide functional and esthetic rehabilitation of the edentulous</p>
Compatible System	Implant Body Diameter(mm)	Implant Platform														
Osstem TS (K121995)	3.5, 3.75	Mini														
	3.75, 3.77, 4.2, 4.25, 4.4, 4.6, 4.63, 4.65, 4.9, 5.05, 5.08, 5.1	Regular														
Straumann Bone Level (only the Roxolid® implants from K140878)	3.3	NC														
	4.1, 4.8	RC														

# SIMDA

Feature	Proposed Device SIMDA Abutment	Primary predicate TiGEN Abutment	SE discussion
			<p>maxilla and mandible. Slight differences in the language of the subject device and primary predicate is Indications for Use statements do not affect the intended use as an endosseous dental implant abutment for support of a prosthesis to restore chewing function. The minor differences between the subject device and the primary predicate device are related to the compatible OEM implant lines and the implant platform diameter.</p>
<p><b>Design Limits for patient-specific abutment (Min. ~ Max.)</b></p>	<p>Maximum Angulation : 0~25°            Maximum Cuff Height : 0.5~5mm            Minimum Diameter : Ø 4.0~ Ø 8.0mm            Minimum Thickness : 0.4mm            Minimum Post Height : 4~6mm</p>	<p>Standard type            Minimum wall thickness(mm): 0.47            Maximum Angulation : 30°            Minimum gingival collar height(mm) : 2.0            Minimum gingival collar height(mm) : 5.0            Minimum gingival collar(Ø) : 3.5,4.0,4.5            Maximum gingival collar(Ø) : 9.5, 11.5            Minimum post height : 4.0            Maximum post height : 6.0, 6.5</p> <p>Octa level type            Minimum wall thickness(mm): 0.47            Maximum Angulation : 30°            Minimum gingival collar(Ø) : 4.0            Maximum gingival collar(Ø) : 9.5, 11.5            Minimum post height : 4.0            Maximum post height : 6.0</p>	<p>The minor difference between the two products in the design parameters are as follow. The minimum diameter of the product compatible with the subject device is larger than the primary predicate device. The diameter of the primary predicate device is Ø3.5mm~Ø11.5mm, while the subject device can be designed from Ø 4.0mm up to Ø8.0mm. The maximum angle of the product compatible with the subject device is smaller than the primary predicate device. The angle of the primary predicate device is 30°, while the subject device can be designed up to 25°.</p> <p>The minimum thickness of the primary predicate device is 0.47, while the subject device can be designed up to 0.4. The angle of the primary predicate device is 30°, while the subject device can be designed up to 25°.</p> <p>The cuff height of the primary predicate device is 2.0mm~5.0mm, while the subject device can be designed from 0.5mm up to 5.0mm.</p> <p>The post height of the primary predicate device is 4.0mm~6.5mm, while the subject device can be designed from 4.0mm up</p>

# SIMDA

Feature	Proposed Device SIMDA Abutment	Primary predicate TiGEN Abutment	SE discussion
			to 6.0mm. Even though there are some minor differences in dimensions, performance testing demonstrated that the subject device has substantially equivalent fatigue performance.
<b>Surface Treatment</b>	None	None	-
<b>Sterile</b>	steam sterilized before use	steam sterilized before use	-

# SIMDA

## Ti Base

Feature	Proposed Device SIMDA Abutment	Primary predicate TiGEN Abutment	Reference Device DD Prefab	SE discussion
<b>Applicant</b>	SIMDA Co., Ltd.	MegaGen Co., Ltd.	Dental Direkt GmbH	=
<b>Part Name</b>	Ti-Base	TiGEN Abutment, ZrGEN Abutment and Scan Healing Abutment	DD Ti-Base 2CUT	=
<b>510(K) No.</b>	K223663	K220562	K191111	=
<b>Classification Name</b>	Endosseous Dental Implant Abutments (872.3630)	Endosseous Dental Implant Abutments (872.3630)	Endosseous Dental Implant Abutments (872.3630)	Identical
<b>Product Code</b>	NHA	NHA	NHA	Identical
<b>Material</b>	Ti-6Al-4V ELI (ASTM F136) Zirconia	Ti-6Al-4V ELI (ASTM F136) Zirconia	Ti-6Al-4V ELI (ASTM F136) Zirconia	Identical

# SIMDA

<p><b>Indications For Use</b></p>	<p>SIMDA Abutments are intended for use with dental implants as a support for single or multiple tooth prostheses in the maxilla or mandible of a partially or fully edentulous patient.</p> <p>It is compatible with the following systems:</p> <table border="1" data-bbox="306 488 741 659"> <thead> <tr> <th>Compatible System</th> <th>Implant Body Diameter(mm)</th> <th>Implant Platform</th> </tr> </thead> <tbody> <tr> <td rowspan="2">Ostem TS (K121995)</td> <td>3.5, 3.75</td> <td>Mini</td> </tr> <tr> <td>3.75, 3.77, 4.2, 4.25, 4.4, 4.6, 4.63, 4.65, 4.9, 5.05, 5.08, 5.1</td> <td>Regular</td> </tr> <tr> <td rowspan="2">Straumann Bone Level (only the Roxolid® implants from K140878)</td> <td>3.3</td> <td>NC</td> </tr> <tr> <td>4.1, 4.8</td> <td>RC</td> </tr> </tbody> </table> <p>All digitally designed abutments for use with SIMDA Abutments are intended to be sent to a SIMDA validated milling center for manufacture.</p>	Compatible System	Implant Body Diameter(mm)	Implant Platform	Ostem TS (K121995)	3.5, 3.75	Mini	3.75, 3.77, 4.2, 4.25, 4.4, 4.6, 4.63, 4.65, 4.9, 5.05, 5.08, 5.1	Regular	Straumann Bone Level (only the Roxolid® implants from K140878)	3.3	NC	4.1, 4.8	RC	<p>The TiGEN Abutment, ZrGEN Abutment and Scan Healing Abutment are intended for use on endosseous dental implants in the edentulous or partially edentulous maxilla or mandible, as an aid in prosthetic rehabilitation.</p> <p>For TiGEN Abutment and ZrGEN Abutment, all digitally designed abutments for use with TiGEN Abutment and ZrGEN Abutment are intended to be sent to a MegaGen-validated milling center for manufacture.</p>	<p>DD Solid Connect® CAD/CAM Abutments are used to support prosthetic restorations in combination with endosseous dental implants in the upper and/or lower jaw. DD Prefab abutments, for the Zimmer Biomet 3i Certain 3.4mm implant bodies, and DD Ti-Base 2CUT abutments, for the Altatech Camlog ScrewLine 3.3mm implant bodies, are indicated for maxillary lateral and mandibular central/lateral incisors only. All digitally designed custom abutments for use with DD Solid Connect® CAD/CAM Abutments are to be sent to a Dental Direkt validated milling center for manufacture.</p>	<p>The subject device is substantially equivalent in indications and design principles to the primary predicate device listed above. Provided tables are comparing the Indications for Use Statements and the technological characteristics of the subject device, the primary predicate device. The Indications for Use Statement (IFUS) for the subject device is substantially equivalent in intended use to the primary predicate device. All are intended for use with endosseous dental implants in the maxilla and mandible to provide functional and esthetic rehabilitation of the edentulous maxilla and mandible. Slight differences in the language of the subject device and primary predicate is Indications for Use statements do not affect the intended use as an endosseous dental implant abutment for support of a prosthesis to restore chewing function. The minor differences between the subject device and the primary predicate device are related to the compatible OEM implant lines and the implant platform diameter.</p>
Compatible System	Implant Body Diameter(mm)	Implant Platform															
Ostem TS (K121995)	3.5, 3.75	Mini															
	3.75, 3.77, 4.2, 4.25, 4.4, 4.6, 4.63, 4.65, 4.9, 5.05, 5.08, 5.1	Regular															
Straumann Bone Level (only the Roxolid® implants from K140878)	3.3	NC															
	4.1, 4.8	RC															

# SIMDA

<b>Titanium base</b>	Angulation	0	0		Identical
	Gingival collar	3.8, 4.0, 4.5	2.2~6.0	Not identified	While there are 3 types of subject devices, 3.8, 4.0, and 4.5, primary predicate devices have various diameters for standard type, C-type, and Octa type.
	Post height	3.5, 5.5	1.2~8.0	Not identified	While there are 2 types of subject devices, 3.5, and 5.5, primary predicate devices have various diameters for standard type, C-type, and Octa type.
	Thickness	0.16~0.87	0.12~1.35	Not identified	The thickness of the primary predicate device is 0.12mm~1.35mm, while the subject device can be designed from 0.16mm up to 0.87mm.
<b>Design Limits for Zirconia top-half (Min. ~ Max.)</b>	<ul style="list-style-type: none"> <li>- Post Angle (°): 0~15</li> <li>- Cuff Height (mm): 0.5~5.0</li> <li>-Post Length (mm): 4.0~6.0</li> <li>-Diameter (Ø, mm): 5.0~8.0</li> <li>-Thickness (mm): 0.4</li> </ul>	<ul style="list-style-type: none"> <li>Minimum wall thickness (mm) : 0.5</li> <li>Maximum angulation (°) : 0</li> <li>Minimum gingival collar (Ø) : 8</li> <li>Maximum gingival collar (Ø) : 10</li> <li>Minimum Gingival collar height (mm) : 2</li> <li>Maximum Gingival collar height (mm) : 5</li> <li>Minimum post height (mm) : 7</li> <li>Maximum post height (mm) : 15</li> </ul>	<ul style="list-style-type: none"> <li>Minimum wall thickness (mm) : 0.5</li> <li>Maximum angulation (°) : 0~20</li> <li>Minimum gingival collar (Ø) : 2.7</li> <li>Maximum gingival collar (Ø) : 7</li> <li>Minimum Gingival collar height (mm) : 0.5</li> <li>Maximum Gingival collar height (mm) : 6</li> <li>Minimum post height (mm) : 4</li> <li>Maximum post height (mm) : 6.5</li> </ul>	<p>The minor difference between the two products in the design parameters are as follow.</p> <p>The minimum diameter of the product compatible with the subject device is larger than the primary predicate device. The diameter of the primary predicate device is Ø8mm~Ø10mm, while the subject device can be designed from Ø 5.0mm up to Ø8.0mm.</p> <p>The angle of the reference device is 0~20°, while the subject device can be designed up to 15°.</p> <p>The minimum thickness of the primary predicate device is 0.5, while the subject device can be designed up to 0.4.</p>	

# SIMDA

				<p>The cuff height of the primary predicate device is 2.0mm~5.0mm, while the subject device can be designed from 0.5mm up to 5.0mm.</p> <p>The post height of the primary predicate device is 7.0mm~15mm, while the subject device can be designed from 4.0mm up to 6.0mm.</p>
<b>Prosthesis Attachment</b>	Cement-retained, Screw-retained	Cement-retained, Screw-retained	Cement-retained, Screw-retained	Identical
<b>Surface Treatment</b>	None	None	None	-
<b>Sterile</b>	steam sterilized before use	steam sterilized before use	steam sterilized before use	Identical



# SIMDA

## **Substantial Equivalence Discussion**

SIMDA Abutment incorporates the same material, indications for use, dimension, design, abutment seat, screw seat, anatomical site, connection, type of retention and technological characteristics as the primary predicate.

The Indications for Use of the subject and primary predicate are identical other than the compatible implant bodies. This difference is mitigated by fatigue testing, reverse engineering, dimensional analysis, and identification of reference predicate for compatible implant bodies. Both the predicate and subject devices are intended to be milled into patient-specific abutments using CAD/CAM technology under the manufacturing control of the sponsor.

Any differences in technology characteristics are accompanied by information that demonstrated the device is substantially equivalent as the predicate and do not raise different questions of safety and effectiveness than the predicate.

SIMDA Abutments are compatible with reference devices (K121995 and K140878). Each SIMDA Abutment platform has a precision implant/abutment interface corresponding to the implant system predicate for that platform.

## **Conclusion**

SIMDA Abutments constitute a substantially equivalent medical device, meeting all the declared requirements of its intended use. This system has the same intended use and fundamental scientific technology as its primary predicate. Therefore, SIMDA Abutment and its predicate are substantially equivalent.