

SIMergy – State Innovations Model
Interactive Learning Environment

Innovation for the States; by the States



NATIONAL ACADEMY
for STATE HEALTH POLICY



The Office of the National Coordinator for
Health Information Technology



Aligning Health IT Implementation with Delivery System Transformation

*Health IT Optimized Care
Coordination: Care Plans and
Data To Support Care Plans*

Health IT Learning Cluster

February 12, 2014



Carolyn Padovano

Health IT Learning Cluster Lead, RTI

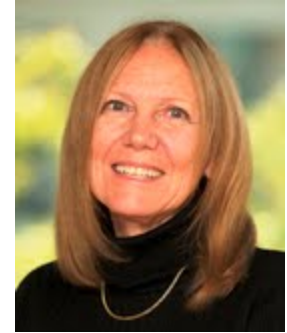

HEALTH IT OPTIMIZED CARE COORDINATION: CARE PLANS AND DATA TO SUPPORT CARE PLANS

Patricia MacTaggart, Senior Advisor, Office of the National Coordinator,
Office of Care Transformation

Building Better Care One Lego® at a Time

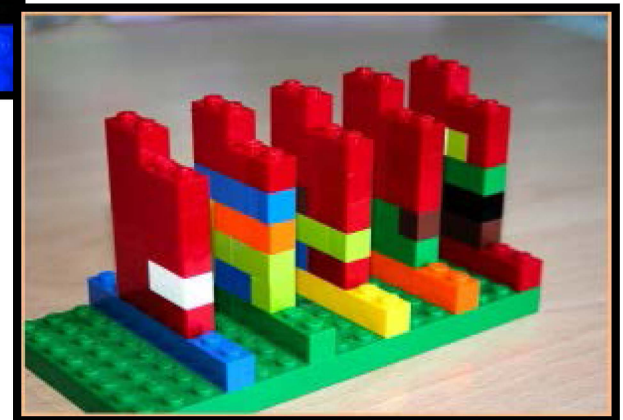
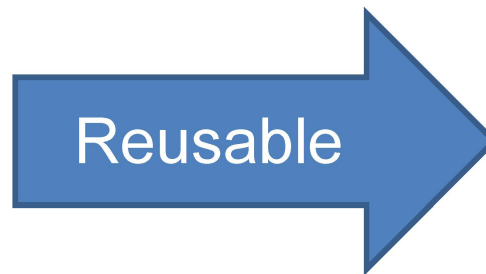
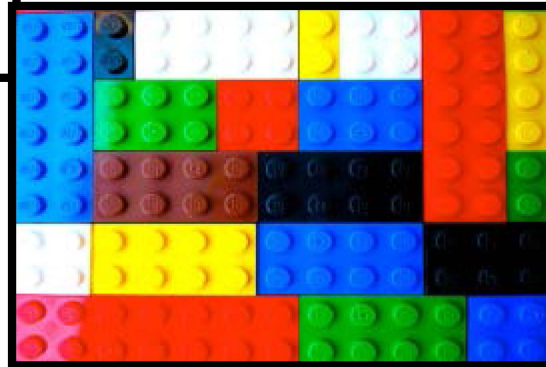
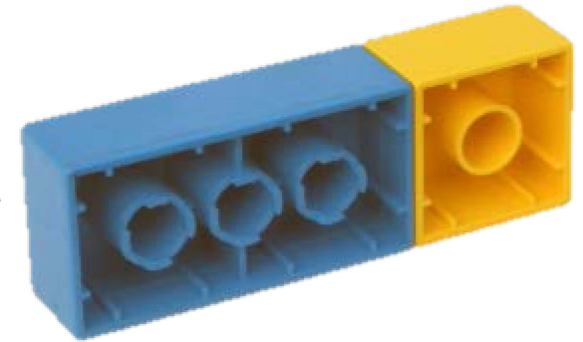
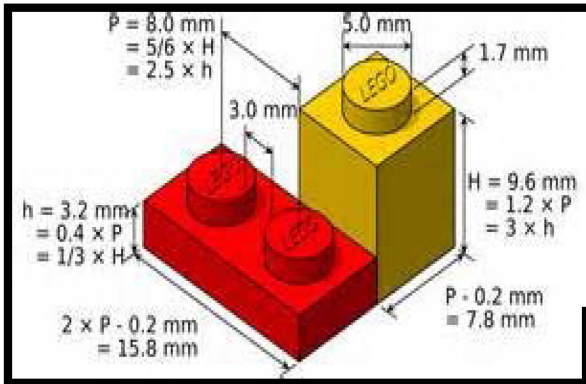

For these priority exchanges of information – What is the purpose of the exchange of information?



“Silo”	Which of these connections is your priority?	For what priority purpose is the information exchanging (Why are we doing this?) (A-E, see key below)
Medical/ Health Care Providers (Hospitals/ Primary Care/ Specialists)	<ol style="list-style-type: none"> 1. BH Providers 2. LTPAC/LTSS 3. Primary/Hospitals/ Specialists 4. Ind./Caretakers 5. Community Care Organizations <ul style="list-style-type: none"> • Vermont & MN: 1-4 • Maine: 1-3 • Massachusetts: 1-5 	<p>Maine: <i>Hospitals</i>-Shared care across the continuum (C); <i>Primary Care</i> -Shared care plan support care team communication (D)</p> <p>Vermont: Started to collect BH, LTPAC, and LTSS providers (not yet individuals), so far mainly with ADTs and lab reports - point-to-point patient care, population health, and analytics to support ACOs (A – D); Medical to Medical connected for ADT, Lab reports, VXU, CCD, transcribed reports (A-D)</p> <p>Massachusetts: <i>BH</i> – thru MassHIway (A-D); <i>LTPAC/LTSS</i> - thru Mass HIway connection & <i>Community Links Portal</i> (A-D); <i>Community Care Orgs.</i> – e-referrals for B-D; <i>Individuals/Caretakers</i> - for D patient portal initiatives req. by Ch 224</p> <p>Minnesota: A-D for all except individual; Individual D</p>
Behavioral Health Providers	<ol style="list-style-type: none"> 1. Primary/Hospitals/Specialists 2. LTPAC/LTSS 3. Ind/caretaker 4. Community Org. <p>Massachusetts: 1,2, 4 Vermont & MN: 1-3</p>	<p>Massachusetts: <i>Primary, Specialists, BH and LTPAC/LTSS</i> – A-D; <i>Community Organizations for e-referrals</i>-B-D</p> <p>Minnesota: A-D for all except individual; Individual D</p>

A - Permanent transfer of care; **B** - Temporary transfer (**B-1**: consult **B-2**: procedure); **C** - Shared care (e.g. HHPoC); **D** - Information to Support Process of Care (care team communication); **E** - Other (name)

For these priority exchanges of information – what is the purpose of the exchange of information?



“Silo”	Which of these connections is your priority?	For what priority purpose is the information exchanging (Why are we doing this?) (See key below)
LTPAC/LSSS Providers	<ol style="list-style-type: none"> 1. Primary/Specialists/ Hospitals 2. BH Providers 3. LTSS Providers 4. Individual/caretakers 5. Community Orgs. <ul style="list-style-type: none"> • Vermont & MN: 1-4 • Massachusetts 1-3, 5 	<p>Massachusetts: Primary/Specialist & BH: through MassHIway -A-D; other LTSS providers- A-D (Section Q referrals, AGD) Community Orgs –e-referrals B-D; Individual - thru Community Link portal – D</p> <p>Minnesota: A-D for all except individual; Individual D</p>
Individual and caretakers	<ol style="list-style-type: none"> 1. Primary/Specialists/ Hospitals 2. BH Providers 3. LTPAC/LTSS Providers 4. Community Orgs. <p>MN: 1-3 Massachusetts: 3</p>	<p>Massachusetts: for LTPAC/LSSS thru community link portals D</p> <p>Minnesota: A-D for all except individual; Individual D</p>
Community Providers	<ol style="list-style-type: none"> 1. Primary/Specialists/ Hospitals 2. BH Providers 3. LTPAC/LTSS Providers 4. Community Orgs <p>Massachusetts: 1-4 MN: 1-3</p>	<p>Massachusetts: for e-referrals for all B-D</p>

A - Permanent transfer of care; **B** - Temporary transfer (**B-1**: consult **B-2**: procedure); **C** - Shared care (e.g. HHPoC); **D** - Information to Support Process of Care (care team communication); **E** - Other (name)

Framing the Discussion: For these priority exchanges of information – what do you need?



“Silo”	For priority providers identified for priority purpose identified earlier slides	For these priority exchanges of information, what do you need? (See key below)
Medical/ Health Care Providers	BH Providers LTPAC/LTSS Providers Community Orgs.	<p><i>Maine:</i> (A) Common vocabulary, data elements and (C) develop a focused plan for a HIE solution for a shared care plan that focuses on a specific population & the business & clinical requirements & workflow related to the selected population.</p> <p><i>Vermont:</i> A & C</p> <p><i>Massachusetts:</i> BH –mental health CCD and consent, legal guidance around exchanging information with non HIPPA covered entities (MOU’s etc.) (A-D);</p> <p><i>LTPAC/LTSS</i> - workflows for new connection/referral types (C); <i>Community Care Orgs.</i> –connecting to non-medical organizations & use cases and workflows for specialist referrals, to community organizations (A-C)</p> <p><i>MN:</i> all but community (A, C, D – based on MN roadmap activity (not yet determined))</p>
Behavioral Health Providers	Primary/Specialists Providers LTPAC/LTSS Providers	<p><i>Maine:</i> A & C</p> <p><i>Vermont:</i> A & C</p> <p><i>Massachusetts:</i> <i>Primary:</i> MH CCD and consent, legal guidance around exchanging information with non HIPPA covered entities (MOU’s etc.) (A-D); <i>Specialists, BH and LTPAC/LTSS</i> - MH CCD and consent, workflows for new connection/referral types (B,C); <i>Community Organizations for e-referrals</i>-use cases and workflows for BH referrals to community organizations, legal guidance around exchanging information with non HIPPA covered entities (MOU’s etc.) (C)</p> <p><i>MN:</i> (A, C, D – based on MN roadmap activity (not yet determined))</p>

A - Common vocabulary-specification; **B** - Model contract language (please specify: for IT vendor; for MCO/CCO/etc.);
C - Guidance on operational/workflow business requirements ; **D** - Other (please specify)

Framing the Discussion: For these priority exchanges of information –what do you need?



“Silo”	For priority providers identified for priority purpose identified earlier slides	For these priority exchanges of information, what do you need? (See key, below)
LTPAC/LSSS Providers	Medical/HC Providers BH Providers LTSS Providers Individual/caretakers	<p><i>Maine: A & C</i> <i>Vermont: A & C</i> <i>Massachusetts: Primary/Specialist & other LTSS providers- workflows for new connection/referral types (C); BH – MH CCD and consent, workflows for new connection/referral types (B-C); Community Orgs - Use cases and workflows for LTPAC/LTSS referrals to community organizations; (C); Individuals/Caretakers guidance to Individuals and Caretakers (A,C)</i> <i>MN: (A, C, D – based on MN roadmap activity (not yet determined))</i></p>
Individual and caretakers	Medical/HC Providers BH Providers LTPAC/LTSS Providers	<p><i>Massachusetts: LTPAC/LTSS - A, C – Guidance to Individuals and Caretakers</i> <i>MN: A, C, D – based on MN roadmap activity (not yet determined)</i></p>
Community Orgs.		<p><i>Massachusetts: Primary– Connecting to non-medical organizations (e.g., YMCA) – A-C; Specialists, BH, LTPAC/LTSS and Community Organizations - use cases and workflows for referrals to community organizations- C; BH - legal guidance around exchanging information with non HIPPA covered entities (MOU’s etc.)-C</i></p>

A - Common vocabulary-specification; **B** - Model contract language (please specify: for IT vendor; for MCO/CCO/etc.); **C** - Guidance on operational/workflow business requirements ; **D** - Other (please specify)

1. **Focus Provider Type(s):**
2. **Focus Purpose:**
3. **Schedule a call to focus on:** _____
4. **Other:** _____
5. **Last Comments:** _____

Information from last web-discussion for background:

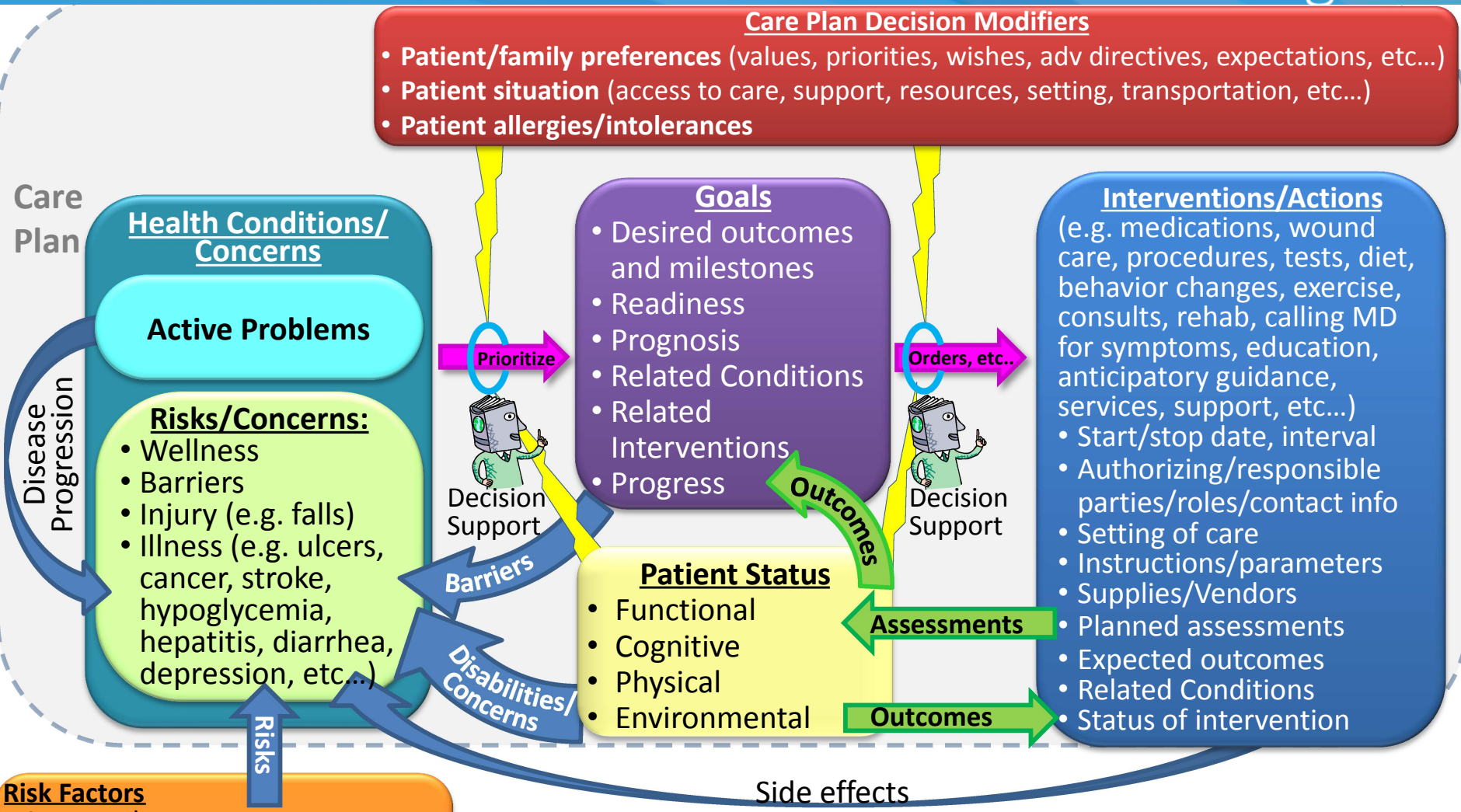

The Care Plan (Concerns, Goals, Interventions, and Care Team), along with Risk Factors and Decision Modifiers iteratively evolve over time

C-CDA Release 1.1 Documents: 8 standard document templates

HL7 Implementation Guide for CDA R2: IHE Health Story Consolidation, DSTU Release 1.1 (US Realm) July 2012

Document Templates: 9

- Continuity of Care Document (CCD)
- Consultation Note
- Diagnostic Imaging Report (DIR)
- Discharge Summary
- History and Physical (H&P)
- Operative Note
- Procedure Note
- Progress Note
- Unstructured Document

Section Templates: 60

Entry Templates: 82

Document Template	Section Template(s)		
Continuity of Care Document (CCD)	Allergies Medications Problem List Procedures Results Advance Directives Encounters	Family History Functional Status Immunizations Medical Equipment Payers Plan of Care	Section templates in GREEN demonstrate CDA's interoperability and reusability.
History & Physical (H&P)	Allergies Medications Problem List Procedures Results Family History Immunizations Assessments	Assessment and Plan Plan of Care Social History Vital Signs History of Present Illness History of Present Illness	Chief Complaint Reason for Visit Review of Systems Physical Exam General Status

3 NEW Documents

- Transfer Summary
- Care Plan
- Referral Note

(Also enhanced Header to enable Patient Generated Documents)

6 NEW Sections

- Nutrition Section
- Physical Findings of Skin Section
- Mental Status Section
- Health Concerns Section
- Health Status Evaluations/ Outcomes Section
- Goals Section

30 NEW Entries

- Advance Directive Organizer
- Cognitive Abilities Observation
- Drug Monitoring Act
- Handoff Communication
- Goal Observation
- Medical Device Applied
- Nutrition Assessment
- Nutrition Recommendations
- Characteristics of Home Environment
- Cultural and Religious Observation
- Patient Priority Preference
- Provider Priority Preference
- and lots more.....

Care Plan Exchange: Conceptual Workflow

Updates and displays Care Plan; stores/transmits data



PHR App



Individual & Caregiver

(Health) Information Exchange Mechanism



Updates and displays Care Plan; stores/transmits data



Other IT System



Service Team
HCBS SETTING



Clinical IT System

Updates and displays Care Plan; stores/ submits data



Care Team
CLINICAL/
INSTITUTIONAL SETTING

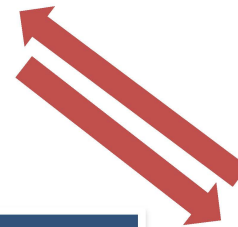

Payer System

Extract, Transform, & Load Care Plan

Move from Patient-Centered to Person-Centered Planning and Information Exchange

Wrap-Up

Let us know if you have any questions!

Health IT Learning System Cluster Team



Carolyn Padovano
Deputy Project Director
cpadovano@rti.org



Christina Miller
Policy Specialist
cmiller@nashp.org

The ONC Team



Patricia MacTaggart
OCT/ONC
Patricia.mactaggart@hhs.gov

Project Leadership



Joe Burton
Project Director
joeburton@rti.org



Anne Gauthier
Project Lead/
Director of Curriculum
agauthier@nashp.org